

**IEA Wind TCP**

**Task 25**



**iea wind**

# **Design and operation of energy systems with large amounts of variable generation**

Final summary report, IEA Wind TCP  
Task 25

Hannele Holttinen et al.

# Design and operation of energy systems with large amounts of variable generation

## Final summary report, IEA Wind TCP Task 25

---

Hannele Holttinen (Recognis, Finland); Juha Kiviluoma, Niina Helistö (VTT, Finland); Thomas Levy (Natural Resources Canada); Nickie Menemenlis (HQ IREQ, Canada); Liu Jun (SGERI, China); Nicolaos Cutululis, Matti Koivisto, Kaushik Das (DTU, Denmark); Antje Orths (Energinet, Denmark); Peter Børre Eriksen (Ea Energy Analyses, Denmark); Emmanuel Neau (EdF, France); Jean-Yves Bourmaud (RTE, France); Jan Dobschinski (Fraunhofer IEE, Germany); Christoph Pellinger, Serafin von Roon, Andrej Guminski (FfE, Germany); Damian Flynn (UCD, Ireland); Enrico Maria Carlini (Terna, Italy); Yoh Yasuda (Kyoto University, Japan); Ryuya Tanabe (CRIEPI, Japan); Simon Watson, Arjen van der Meer (TU Delft, The Netherlands); Germán Morales-España (TNO, The Netherlands); Magnus Korpås (NTNU, Norway); Til Kristian Vrana (SINTEF, Norway); Ana Estanqueiro, António Couto (LNEG, Portugal); Bernardo Silva (INESC-TEC, Portugal); Sergio Martin Martinez (University Castilla La Mancha, Spain); Lennart Söder (KTH, Sweden); Goran Strbac, Danny Pudjianto, Spyros Giannelos (Imperial College, UK); Bethany Frew, Bri-Mathias Hodge, Shahil Shah (NREL, USA); J. Charles Smith, Debbie Lew, Mark O'Malley (ESIG, USA); Vasiliki Klonari (WindEurope)

ISBN 978-951-38-8757-5

VTT Technology 396

ISSN-L 2242-1211

ISSN 2242-122X (Online)

DOI: 10.32040/2242-122X.2021.T396

Copyright © VTT 2021

JULKAISIJA – PUBLISHER

VTT

PL 1000

02044 VTT

Puh. 020 722 111

<https://www.vtt.fi>

VTT

P.O. Box 1000

FI-02044 VTT, Finland

Tel. +358 20 722 111

<https://www.vttresearch.com>

## Preface

A research-and-development (R&D) task on the Design and Operation of Power Systems with Large Amounts of Wind Power was formed in 2006 as IEA Wind Task 25.<sup>1</sup> The aim of this R&D task is to collect and share information on the experiences gained and the studies made on power system impacts of wind power and to review methodologies, tools, and data used. The following countries and institutes are currently involved in the collaboration:

1. Canada: Hydro-Québec Research Institute (IREQ)
2. China: State Grid Energy Research Institute (SGERI)
3. Denmark: Technical University of Denmark (DTU); Energinet; Ea Energy Analyses
4. European Wind Energy Association (WindEurope)
5. Finland (operating agent): VTT Technical Research Centre of Finland Ltd (VTT); Recognis Oy
6. France: Electricité de France Research and Development Center (EDF R&D); Réseau de Transport d'Electricité - Research and Development center (RTE R&D)
7. Germany: Fraunhofer Institute for Energy Economics and Energy System Technology (Fraunhofer IEE); Research Centre for Energy Economics (FfE)
8. Ireland: Sustainable Energy Authority of Ireland (SEAI); University College Dublin (UCD); Energy Reform
9. Italy: Terna Rete Italia
10. Japan: Central Research Institute of Electric Power Industry (CRIEPI); University of Kyoto
11. Norway: Norwegian University of Science and Technology (NTNU); Foundation for Scientific and Industrial Research (SINTEF)
12. Netherlands: Delft University of Technology (TUDelft); TNO
13. Portugal: National Laboratory on Energy and Geology (LNEG); Institute for Systems and Computer Engineering, Technology, and Science (INESC-TEC)

---

<sup>1</sup> IEA WIND is a Technology Collaboration Programme (TCP) for Cooperation in the Research, Development, and Deployment of Wind Turbine Systems within the International Energy Agency (IEA).

14. Spain: University of Castilla La Mancha (UCLM); Universidad Pontificia Comillas
15. Sweden: Royal Institute of Technology (KTH)
16. United Kingdom: Imperial College London
17. United States: National Renewable Energy Laboratory (NREL); Energy Systems Integration Group (ESIG); U.S. Department of Energy (DOE).

IEA Wind Task 25 produced a report in 2007 on the state-of-the-art knowledge and results on wind integration that had been gathered so far, published in the VTT Working Papers series. Summary reports of four subsequent phases have also been published by VTT: 2009 (VTT Research Notes 2493), 2012 (VTT Technology T75), 2016 (VTT Technology T268), and 2019 (VTT Technology T350). These reports presented summaries of selected, recently finished studies. All these reports are available on the IEA Wind Task 25 website: <https://iea-wind.org/task25/>.

In addition, IEA Wind Task 25 developed guidelines on the recommended methodologies when estimating the system impacts and costs of wind power integration; this was published in 2013 as RP16 of IEA Wind with an update in 2018 to also include solar photovoltaics. The recommended practices reports are available on the website <https://iea-wind.org/iea-publications/>. The work continues with a sixth period (2021–2024), where the aim is to update the Recommended Practices for Wind and PV Integration Studies.

As the work has evolved from wind integration studies to cover both wind and solar energy, and both electricity and energy systems, the name of Task 25 was changed to Design and Operation of Energy Systems with Large Amounts of Variable Generation in 2018. This report summarizes the main results of the first five 3-year phases of IEA Wind Task 25 (2006–2020).

September 2021, Authors

# Contents

<b>Preface</b> .....	<b>3</b>
<b>Contents</b> .....	<b>5</b>
<b>List of acronyms</b> .....	<b>8</b>
<b>Executive summary</b> .....	<b>12</b>
<b>1. Introduction</b> .....	<b>17</b>
<b>2. Variability and uncertainty of power system- wide wind and solar</b> .....	<b>23</b>
2.1 Variability .....	23
2.1.1 Variability from actual wind energy generation .....	23
2.1.2 Smoothing impact and metric for system size and wind dispersion 29	
2.1.3 Variability from simulated wind energy generation .....	31
2.1.4 Wind and solar complementarity.....	34
2.2 Uncertainty.....	36
2.2.1 Now-casting for observability.....	36
2.2.2 Extreme forecast error events.....	37
2.2.3 Ramp forecasting.....	38
2.2.4 Forecasting low wind and solar events.....	39
2.2.5 Improvements to forecasting .....	40
2.2.6 Forecast error data simulations .....	43
<b>3. Transmission planning</b> .....	<b>45</b>
3.1 Regional transmission planning.....	46
3.1.1 European grid scenarios for high shares of wind power .....	46
3.1.2 Regional grid studies in North America .....	48
3.2 National transmission planning studies.....	51
3.3 Offshore grid infrastructure.....	55
3.3.1 Grid planning studies with offshore grids.....	56
3.3.2 Energy islands .....	58
3.4 Overplanting wind capacity to transmission line .....	59
<b>4. Ensuring long-term reliability and security of supply</b> .....	<b>61</b>
4.1 Estimating capacity value of wind power.....	61
4.1.1 Multiple-year data sets needed for capacity value estimates .....	62
4.2 Assessing resource adequacy in power systems with wind power .....	63
4.2.1 Capturing extreme events .....	64
4.2.2 Multi-area methods .....	64
4.2.3 New metrics and methods .....	66
<b>5. Ensuring short-term system reliability</b> .....	<b>68</b>
5.1 Operating reserves .....	68

5.1.1	Experience of operating reserves in regions with high shares of wind power .....	69
5.1.2	Estimating requirements for operating reserves.....	71
5.2	Stability and grid security .....	76
5.2.1	Experience on stability issues with variable generation.....	76
5.2.2	Studies on frequency stability .....	79
5.2.3	Studies for other stability issues.....	84
5.2.4	Impact of HVDC connections on stability.....	86
<b>6.</b>	<b>Maximizing the value of wind power in operations .....</b>	<b>87</b>
6.1	Estimating the value of wind energy .....	87
6.2	Curtailments .....	88
6.2.1	Experience in curtailments .....	89
6.2.2	Estimating future curtailments in integration studies .....	93
6.3	Using wind power plants for grid support services.....	94
6.3.1	Balancing services with 10- ... 30-minute response times.....	95
6.3.2	Regulation/AGC/secondary response .....	95
6.3.3	Primary frequency response from wind power .....	96
6.3.4	Fast frequency support from wind power.....	97
6.3.5	Services for voltage support .....	98
6.3.6	New services for stability support.....	99
6.4	Operational practices: Grid.....	104
6.4.1	Congestion management .....	104
6.4.2	Security margins and forecasting for transmission.....	108
6.4.3	Dynamic line rating .....	109
6.4.4	Transmission and distribution system operators' coordination...	114
6.5	Operational practices: Market design.....	115
6.5.1	Challenges and solutions for electricity markets with high shares of variable generation .....	115
6.5.2	Market design to enable wind power integration.....	117
6.5.3	How to increase market value for wind energy .....	119
6.5.4	Increasing revenue sufficiency from energy-only markets.....	122
6.6	Flexibility .....	125
6.6.1	Adequacy of flexibility in future power systems.....	125
6.6.2	Flexibility from hydropower with storage.....	128
6.6.3	Flexibility from thermal power plants and power and heat sector coupling.....	132
6.6.4	Flexibility through use of transmission and interconnectors to neighboring area.....	133
6.6.5	Flexibility from demand-side measures .....	134
6.6.6	Flexibility from storage .....	135
6.6.7	Comparing flexibility options.....	139
<b>7.</b>	<b>Pushing the limits: Toward 100% shares of renewables .....</b>	<b>142</b>
7.1	Experience of near 100% inverter-based power systems .....	142

7.2	Challenges for near 100% renewables system operation .....	143
7.3	Study methodologies for near 100% renewables system operation.....	145
7.3.1	Operational models: Unit commitment and Economic Dispatch.	146
7.3.2	Planning timescale: capacity expansion .....	147
7.3.3	Dynamics: Stability.....	148
7.4	Studies for 100% renewable power systems.....	151
7.5	Toward carbon-neutral energy systems .....	152
7.6	Stability of 100% variable renewable grid.....	156
<b>8.</b>	<b>Conclusions .....</b>	<b>159</b>
	<b>Acknowledgments .....</b>	<b>162</b>
	<b>References.....</b>	<b>163</b>

## Appendices

### Appendix A: Ongoing projects

## Abstract



## List of acronyms

AC	alternating current
AEMO	Australian Energy Market Operator
aFRR	automatic frequency restoration reserve
AGC	automatic governor control
BESS	battery energy storage system
CO <sub>2</sub>	carbon dioxide
Coreso	centralized regional security coordinator
CorRES	Correlations in Renewable Energy Sources
DC	direct current
DLR	dynamic line rating
DS3	Delivering a Secure, Sustainable Electricity System
DSO	distribution system operator
DTR	dynamic transmission rating
DWD	German Weather Service
ECMWF	European Centre for Medium-Range Weather Forecasts
EES	electrical energy storage
EMT	Electromagnetic transient
ENTSO-E	European Network of Transmission System Operators for Electricity
ERCOT	Electric Reliability Council of Texas
ERGIS	Eastern Renewable Generation Integration Study
ESIG	Energy Systems Integration Group
EUE	Expected unserved energy

FCR	frequency containment reserve
FFR	fast frequency response/reserve
GFS	Global Forecast System
GW	gigawatt
GWs	gigawatt-second
HVAC	high-voltage alternating current
HVDC	high-voltage direct current
Hz	hertz
IBR	inverter-based resource
IEA	International Energy Agency
IRENA	International Renewable Energy Agency
KIUC	Kauai Island Utility Cooperative
kV	kilovolt
LCOE	levelized cost of energy
LOLE	loss-of-load expectation
LOLP	loss-of-load probability
MAF	Mid-term Adequacy Forecast
MARI	Manually Activated Reserves Initiative
MERRA-2	Modern-Era Retrospective analysis for Research and Applications, Version 2
mFRR	manual frequency restoration reserve
MIGRATE	Massive Integration of Power Electronic Devices
MISO	Midcontinent Independent System Operator
MVA	megavolt ampere
MW	megawatt
MWh	megawatt hour
NARIS	North American Renewable Integration Study
NERC	North American Electric Reliability Corporation
NREL	National Renewable Energy Laboratory
NSCOGI	North Seas Countries' Offshore Grid Initiative

NSEC	North Seas Energy Cooperation
NSON	North Sea Offshore Network
NSRDB	National Solar Radiation Database
NSWPH	North Sea Wind Power Hub
OHL	overhead lines
OSMOSE	Optimal System-Mix of Flexibility Solutions for European Electricity
ORDC	operating reserve demand curve
OTC	optimal topology control
PCWIS	Pan-Canadian Wind Integration Study
PFR	primary frequency response
POD	power oscillation damping
PRAS	Probabilistic Resource Adequacy Suite
PROMOTioN	PROgress on Meshed HVDC Offshore Transmission Networks
PV	solar photovoltaics
R&D	research and development
REQ	equivalent system radius
RIIA	Renewable Integration Impact Assessment
RM	ramping margin
ROCOF	rate of change of frequency
SCADA	supervisory control and data acquisition
SNSP	system non-synchronous penetration
SP	synchronizing power
SPP	Southwest Power Pool
SRL	secondary reserve activation
SSCI	sub-synchronous controller interaction
STATCOM	static synchronous compensator
TCP	Technology Collaboration Programme
TERRE	Trans European Replacement Reserves Exchange
TSO	transmission system operator
TWh	terawatt hour

TYNDP	Ten-Year Network Development Plan
VIBRES	variable inverter-based renewable energy source
VRE	variable renewable energy
VSC	voltage source converter
WIND	Wind Integration National Dataset
WPP	wind power plant
WRF	Weather Research and Forecasting (mesoscale weather model)

## Executive summary

The design and operation of power and energy systems is an evolving field. As ambitious targets toward net-zero carbon energy systems are announced globally, many scenarios are being made regarding how to reach these future decarbonized energy systems, most of them involving large amounts of variable renewables, mainly wind and solar energy. The secure operation of power systems is increasingly challenging. The impact of both increased amounts of variable renewables as well as new electrification loads together with increased distribution system resources that require more coordination between transmission and distribution systems will lead to somewhat different challenges for different systems. Tools and methods to study future power and energy systems also need to evolve, and both short-term operational aspects (such as power system stability) and long-term aspects (such as resource adequacy) will probably see new paradigms of operation and design. The experience of operating and planning systems with large amounts of variable generation is accumulating, and research to tackle the challenges of inverter-based, nonsynchronous generation is on the way. Energy transition and digitalization also bring new flexibility opportunities, both short and long term.

This report brings together experience and study results from 17 countries working in the international collaboration within the International Energy Agency (IEA) Wind Technology Collaboration Programme (TCP) Task 25. Main findings are reported on:

- How to incorporate wind and solar generation and forecasts within system operation and simulations (Section 2)
- How to plan for the long-term adequacy of transmission grids and generation capacity (Section 3 and Section 4)
- How to manage the operation of power systems, including stability aspects (Section 5)
- How to increase the value of wind energy in future power and energy systems, avoiding unnecessary curtailments, providing system support from wind power plants (WPPs), and improving operational practices and flexibility (Section 6)
- Pushing the limits toward 100% renewable systems, highlighting challenges and evolving methodologies needed for the assessments (Section 7).

The appendix provides links to some ongoing research projects contributing to Task 25 for 2021–2024.

The participating countries report increasing shares of wind in electricity consumption on average. In 2020, wind and solar shares were more than 60 % of electricity consumption in Iowa, North Dakota and Kansas; 50% in Denmark; more than 35% in Ireland, Oklahoma and South Kansas; more than 30% in Germany and Wyoming; and more than 20% in Portugal, Spain, Greece, the United Kingdom, the Netherlands, Sweden and in Texas and 5 other states in the United States. During certain hours, more than 100% instantaneous shares of wind have been achieved

in Denmark (213%) and Portugal (109%), Ireland has seen 95% of demand from wind, and more than 80% of wind + solar photovoltaics has been recorded in Italy and Germany. Other than the island power systems of Ireland and Great Britain, as well as the synchronous system of Texas, these high shares of wind have not been power system wide. The share of wind and solar in large continental systems, such as Central Europe and the U.S. Eastern Interconnection and Western Interconnection are still moderate (10%–15%).

### **Variability and uncertainty of wind power—the challenge and an important input**

Increasing volumes of real and aggregated wind power generation data are available for power systems and balancing areas, while meteorological inputs of improving quality are also providing better simulated data for wind at relevant heights above ground level, to capture the smoothing impact and provide representative data sets for future simulations.

The dispersion of WPPs in the power system area will impact variability. Large power system-wide data from Europe shows that the occurrence of low wind generation of less than 5% of rated capacity is very rare (1 hour per year), and the longest periods of less than 10% of installed capacity are less than 40 hours duration. Storm events result in the largest wind generation ramps—and the largest forecast errors. Turbine technology development has resulted in less variations from the wind power fleets. Wind and solar have complementarity throughout the day and the year, and their aggregated variability is considerably less than that of each resource alone.

Short-term forecasting is still improving in accuracy. Probabilistic forecasts provide more data for system operation, providing better assessment of the forecast uncertainty. Examples of simulating wind forecast errors are given for future power system simulations.

### **Toward regional transmission planning—with offshore grids**

Demand growth due to electrification and retirements of thermal generation, in addition to the large growth of wind and solar generation, are driving planning scenarios for the future grid. Increasing transmission capacity is seen in all future scenarios. Transmission helps reduce the impacts of the variability of wind, increases the reliability of the electric grid, and helps make more efficient use of the available generation resources. Although costs for wide-spread expansions of the grid are significant, they make up a relatively small component of the total annualized costs in the scenarios and provide a good benefit-to-cost ratio. Larger amounts of wind and solar give even larger benefits for transmission assets. Investing in interconnectors for regional and continental transmission show increasing value.

Decarbonizing other energy sectors and sector coupling are expected to further increase the importance of offshore wind in the green transition. Offshore grids and energy islands are seen as future parts of the interconnected transmission system.

### **Resource adequacy—from estimating capacity value of wind to changing the way future system adequacy is assessed**

Wind has a capacity value, which will be higher for larger areas of well-dispersed wind capacity. Concerns for generation capacity (resource) adequacy in future systems where wind and solar energy become dominant are emerging. New metrics and methods are needed to account for flexibility in demand and storage that are not captured in current tools because at some point the traditional ways of increasing peaking capacity will become costly. Considering power system-wide resource adequacy with multi-area methods is important and represents recent practice in Europe. Analyses need data from more weather years to capture the extreme weather events that might occur more often in the future.

### **Short-term balancing—from estimating operating reserve requirements to assessing stability**

The impacts of wind and solar energy on short-term reliability involve potential impacts on the short-term balancing of supply and demand and setting a proper amount of operational reserves for frequency control. With larger shares of solar and wind power, the impact on power system dynamics is increasingly important to assess. In addition to assessing the impacts of variability and uncertainty, the non-synchronous connection of inverters will also need to be considered.

The impacts of wind and solar on operating reserves was a traditional integration study output. The experience from Germany, Texas, and the U.S. Western Interconnection show another outcome: Changing operational practices provides greater savings in reserves utilization than wind and solar variability adds. Sharing balancing, moving to faster dynamic reserve setting, and using WPPs for fast response have proved to be powerful tools for system operation.

The first experience of stability issues related to wind and solar was highlighting the importance of control and protection settings in wind and solar power plants for responses in fault events. The system stability analyses largely began with frequency stability, where new tools have been developed for inertia monitoring. Mitigation methods have focussed on ensuring sufficient synchronous power plants remain online, faster responding frequency control, and deployment of synchronous condensers. Weak grid issues are also studied, as reduced short-circuit current levels, and reduced voltage support, due to displacement of synchronous generators, also increase the area affected by voltage depression as a consequence of a grid fault. Enhanced capabilities to support the grid can be implemented through grid-forming converters in WPPs.

### **Maximizing the value of wind power and minimizing curtailments—improved operational practices, flexibility, and offering grid support services**

A more flexible power system can use variable energy sources at higher value, and hence the main way forward in maximizing the value of wind power lies outside wind power itself; however, wind power can also increase its value by providing system services. Particularly in surplus generation situations, this helps all WPPs to avoid

sourcing system services from conventional power generation and forcing more curtailment of wind power.

Although some curtailment can be efficient for system operation, extensive curtailment of variable power is an indication that the flexibility of the power system is inadequate. The recent information from curtailments show how the previously large curtailments in China have been mitigated, mainly by new grid build-out. In Europe, curtailments are gradually increasing with increasing wind and solar shares. Grid bottlenecks are the main cause, but also system constraints due to stability issues play a role (Ireland, Texas, and Italy).

Wind and solar power plants have already proved their capabilities for providing frequency and voltage support services. Wider use of these services as well as their remuneration, instead of mandating them in grid codes is still evolving. Market design plays a role to enable bidding services in smaller quantities and near real time to avoid or reduce the impact of forecast errors. New capabilities are a subject of research, and how the future system defines the needs for grid-forming capabilities, for example, is yet to be experimented.

Operating the grid with near-real-time information to determine security margins as well as active power management (phase-shifting transformers, dynamic line rating, power flow controllers) and reactive power management (reactors/capacitors, synchronous compensators, STATCOMs) is helping to make the best use of the existing grid infrastructure. Congestion management is evolving, and new ways to capture flexibility from distribution system-connected resources are developing.

Increased flexibility, dynamic prices, and market design to allow new flexibility providers will impact the main income for WPPs for their energy generated in the future. Particularly surplus energy situations, that now see prices plummet, would be mitigated by new demand, also through exports and storage. This would retain the value of wind during surplus hours.

Estimating the value of wind energy in future energy systems is replacing older efforts for estimating a system integration cost—notation that never reached full approval for the methods used and has outlived its usefulness.

### **Pushing the limits toward 100% renewable power systems and net-zero energy systems**

Many techno-economic studies have examined how hourly energy balances could be maintained in a 100% renewable power system. As the ambitious targets toward net-zero carbon energy systems are announced globally, many scenarios are being made regarding how to reach the future decarbonized energy systems. Although the operational details can vary greatly depending on the applied methodology, power system stability has generally been overlooked as part of 100% (energy-balancing) studies, where the main focus is on hourly consumption-generation matching.

The first studies have been made on the stability of 100% inverter-based systems, showing promising results. Wind and solar energy will certainly make a large contribution to future power systems and provide the added renewable energy needed for ambitious increases in electrification demand—150%–300% of current



electricity demand. They also have the potential to form the backbone of future power systems, when the full range of inverter capabilities are utilised. This is still work in progress, where new paradigms of non-synchronous power system operation and long-term resource adequacy are developed, with a suite of new tools and methods being implemented for system operators.

## 1. Introduction

There is an increasing amount of practical experience from wind integration. In 2016, wind energy covered approximately 10% of European Union power demand. This share increased to 15% in 2020. The yearly wind shares of consumption in Europe are presented in Figure 1 and wind and solar share of generation in the United States in Figure 2. In 2020, the power mix shifted significantly toward renewables following lockdown measures, mainly due to depressed electricity demand: wind and solar shares were more than 60 % of electricity consumption in Iowa, North Dakota and Kansas; 50% in Denmark; more than 35% in Ireland, Oklahoma and South Kansas; more than 30% in Germany and Wyoming; and more than 20% in Portugal, Spain, Greece, the United Kingdom, the Netherlands, and Sweden and in Texas and 5 other states in the United States (IEA Wind, 2021; USDoE, 2021).

Other than the island systems of Ireland and Great Britain as well as the synchronous system of Texas, those high shares of wind and solar have not been recorded at the synchronous power system level. The share of wind and solar in large continental systems, such as in Central Europe and the U.S. Eastern Interconnection and Western Interconnection are still moderate, on the order of 10%–15%.

It is also interesting to see the instant high shares of wind, as presented in Table 1 and Figure 4. In Denmark, variable renewables exceeded demand for 845 hours and reached a high of 213% of demand in 2020. In the Denmark West market area, >100% shares were recorded during 2117 hours and reached 350% during that most extreme hour (3637 MW wind + solar photovoltaics [PV] and 1041-MW demand). In Portugal, >100% wind events are also occurring; the maximum was 109% of demand in 2018. Ireland has seen 95% of demand from wind, against an allowable 70% share from nonsynchronous sources (when exporting). High shares were also recorded in Spain and Germany. The average share of wind energy does not tell us all about the challenges of integrating wind power to power systems; we also use a metric where the installed wind capacity is presented as the share of minimum load and export capability, shown in Figure 3.

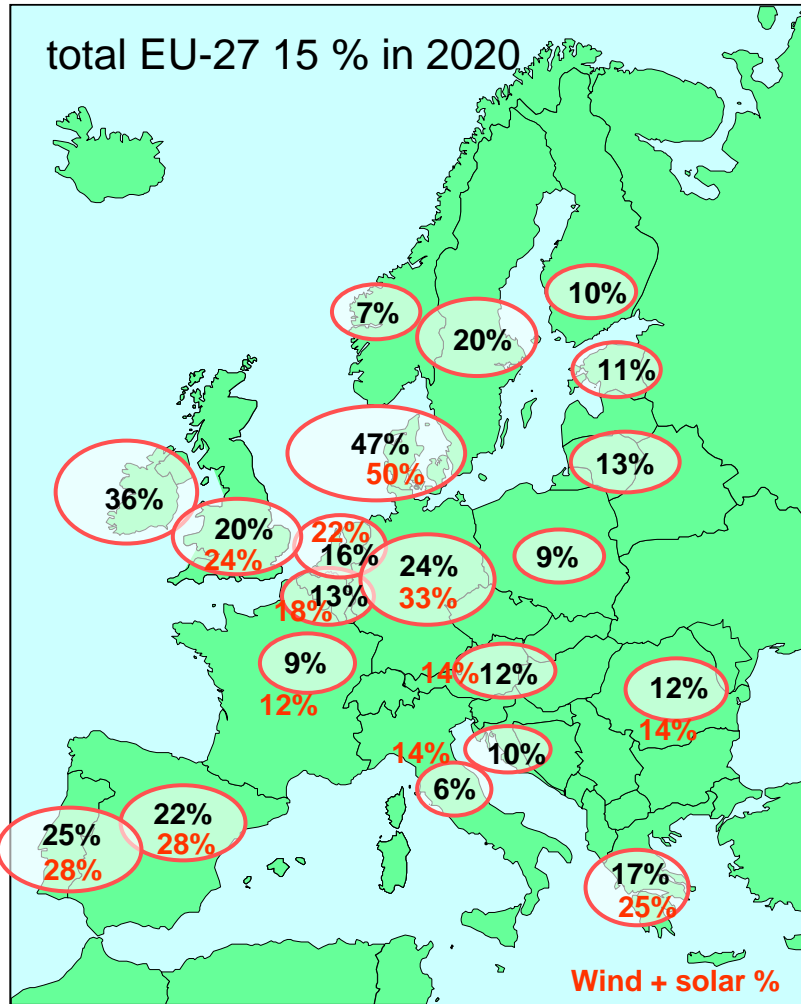

Figure 1. Share of wind-generated electricity from total electricity consumption in Europe in 2020 (Source of data: IEA *Wind TCP Annual Report 2020* and WindEurope statistics, <https://windeurope.org/>). The variable generation shares (wind + solar PV) are shown in red.

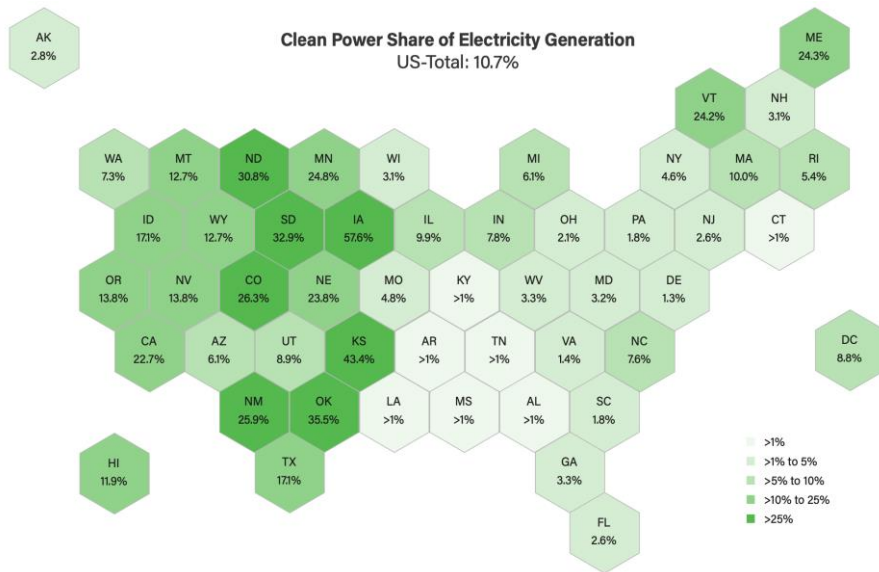

Figure 2. Share of wind and solar generated electricity from total electricity generation in the United States in 2020. Iowa had more than 50% average share of wind energy and Kansas more than 40%, both have mostly wind energy (Source: ACP, 2021).

Table 1. Average and maximum wind shares of demand, recorded in 2020 (values in red are from previous years).

Country	Wind GW	Wind TWh/a	solar GW	solar TWh/a	Peak load GW	Min load GW	Load TWh/a	Inter-connectors max export capacity GW	wind and solar max in an hour	max during a day	max during a month	Wind average share of energy	wind + PV average share of energy	Wind share of peak load	Wind share of min load + max export capability
Denmark	6.2	16.2	1.3	1.2	6.7	1.6	35	6.3	213 %	138 %	67 %	47 %	50 %	93 %	78 %
Ireland	4.3	11.1			5.3	2.0	29	1.0	96 %		56 %	38 %	38 %	81 %	146 %
Island of Ireland	5.6	13.8	0.3	0.1	6.9	2.4	37	1.0	89 %		56 %	37 %	38 %	81 %	165 %
Texas	31	95	6		75	27		1.2	59 %			24 %		41 %	109 %
Portugal	5.4	12.1		1.3	8.7	5.0	49	3.8				25 %	27 %	62 %	61 %
Germany	62.2	131.0	54.1	51.4	75.7	33.0	553	16.8	74 %			24 %	33 %	82 %	125 %
Spain	27	53.8	14	19	40	16	238	8.1	70 %	59 %	34 %	23 %	31 %	66 %	110 %
GB	23.4	72.9			50.0	18.1	324	4.0				23 %	23 %	47 %	106 %
Sweden	10.1	27.5			26.6	8.9	136	10.0				20 %	20 %	38 %	53 %
France	17	39	10	13	83	29	445	17.0	32 %	26 %	14 %	9 %	12 %	21 %	38 %
Italy	10.6	18.5			56.6	19.0	302	3.6				6 %	6 %	19 %	47 %

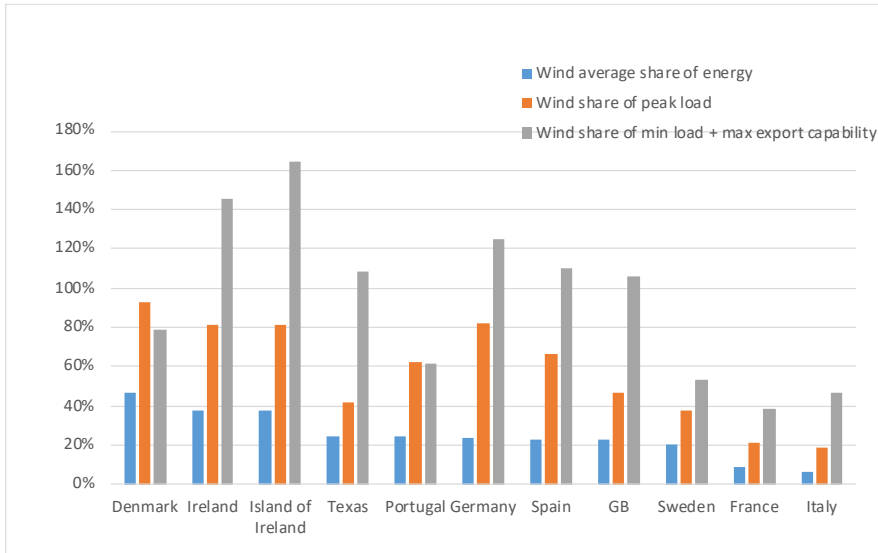

Figure 3. Wind shares of consumed electric energy, peak load capacity, and during a critical low-load situation (wind installed capacity relative to minimum load and maximum export capacity) in year 2020 (Source: Table 1).

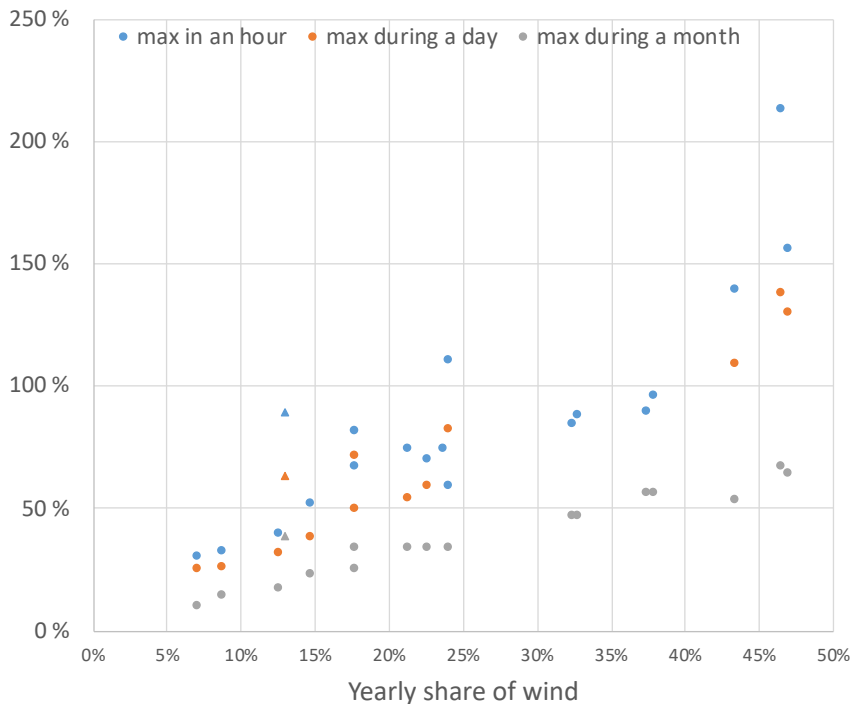

Figure 4. Wind energy share in 1 hour, 1 day, and 1 month relative to the average share during a year. Recorded values from years 2017, 2019, and 2020 from Denmark, France, Germany, Portugal, Ireland, Texas, and Italy (combined wind and solar data from 2017, marked with triangles).

Wind power production introduces additional variability and uncertainty into the operation of the power system, over and above that which is contributed by load and other generation technologies. To meet this challenge, there is a need for more flexibility in the power system. The increased need for the required flexibility depends on several factors, such as how much wind power is embedded in the system and how much flexibility already exists in the power system. Because system impact studies are often the first steps taken toward defining feasible wind penetration targets within each country or power system control area, it is important that commonly accepted standard methodologies related to these issues are applied (see Recommended Practices for Wind and Solar Integration Studies Holttinen (Ed.) 2018) The summary reports that gather findings from experience and study results give valuable information on the challenges, benefits, and mitigation possibilities for wind integration (Holttinen et al., 2009; 2012; 2016; 2019). This report is the last in this

series, including updates from more recent results, but it keeps some of the previous results that are still valid.

The case study results are summarized in seven sections: First, Section 2 provides updated information on the variability and uncertainty of large-scale wind power. Sections 3 and 4 address the long-term planning issues with wind power: grid planning and capacity adequacy. Sections 5 and 6 address the operational impacts: short term reliability (stability and reserves) and maximizing the value in operational timescales (balancing-related issues). Section 7 summarizes recent wind integration studies for higher shares of wind power, and Section 8 concludes. The appendix provides links to some ongoing research contributing to Task 25 for 2021–2024.

## **2. Variability and uncertainty of power system-wide wind and solar**

Data for wind power generation covering balancing area-wide and system-wide regions is an important input to integration studies. The inability to capture the smoothing effect of variability and uncertainty from aggregated sites and future wind power forecasting will result in poor estimates for the power system impacts of wind power.

Variability in wind power generation causes changes to the operation of other generation. Responding to uncertainty in initial plans for wind generation leads to changes in shorter timescales. Wind is only one source of variability and uncertainty in the electric system. Electric demand, unscheduled equipment unavailability, run-of-river hydro, or solar PV generation will add their shares to the total aggregated variability in the power system. An operator must react to the net system variability and uncertainty. Simply adding individually established impacts for each variability and uncertainty source will lead to inefficient management of the power system.

In addition to variability and uncertainty, at larger shares of wind and solar, their connection by inverters, in an asynchronous way, brings changes to power system operation. This is discussed in Section 5.

### **2.1 Variability**

There is a significant smoothing effect in both the variability and uncertainty of wind power when looking at power system-wide areas. The extent of the smoothing effect will depend on the dimensions of the area, the location and dispersion of wind power plants (WPPs) in the area, and the local meteorology, among others. In previous work, it has been shown that the smoothing effect is also valid for extreme variations and extreme forecast errors, which are relatively smaller for larger areas. It has been found that there is a near linear relationship between variability and predictability. A lower variability of wind generation also leads to reduced forecast errors. Offshore wind power will present more variability and uncertainty if a large part of wind power generation is concentrated in a smaller area. Variability is also lower for shorter timescales (Holtinen et al., 2016).

#### **2.1.1 Variability from actual wind energy generation**

Figure 5 depicts an example of wind and load for one country/balancing area showing the general variability of aggregated wind power from Germany.



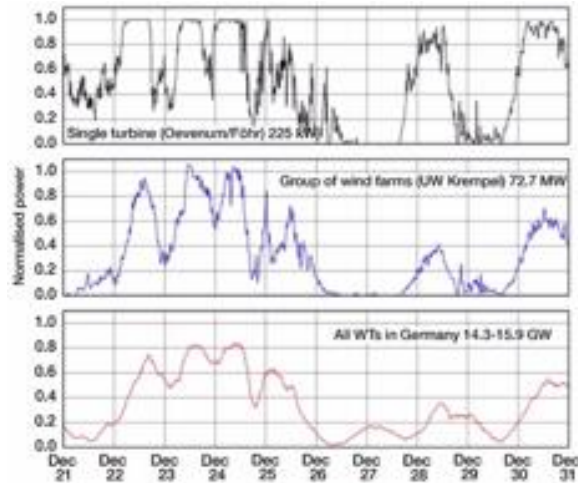

Figure 5. Smoothing impact of wind power production in Germany—the relative variability smooths out as more and more WPPs are aggregated (Source: Fraunhofer IEE).

There is more and more real data for large-scale wind power generation available that were previously the subject of research. The variability of actual wind energy generation in the European Union has been analyzed by WindEurope with their Daily Wind Power Numbers web tool (<https://windeurope.org/about-wind/daily-wind/>). Energy generation and demand profiles across Europe and the shares of wind in different countries are published every day from the day-before information provided via the European Network of Transmission System Operators for Electricity (ENTSO-E) transparency platform, and combined with WindEurope annual installation capacity (Figure 6). The spread in monthly generation values, as well as the frequency distribution showing how often different levels of wind power are generated are shown in Figure 7 and Figure 8.

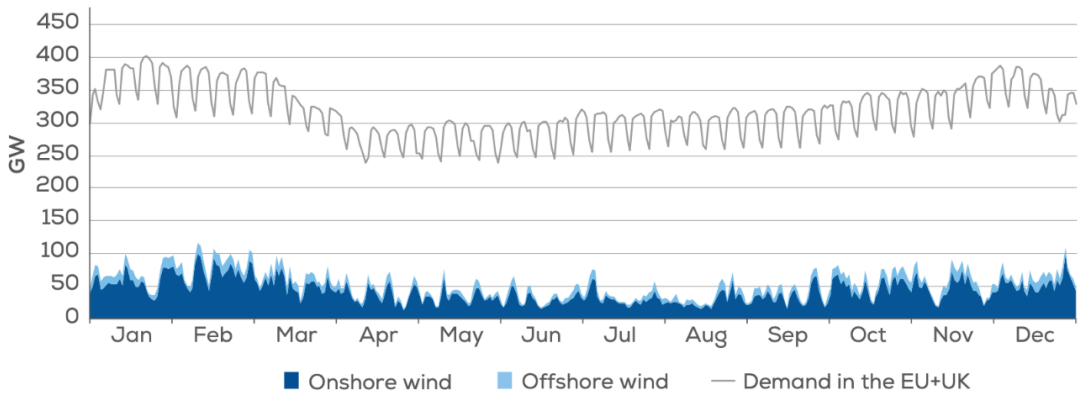
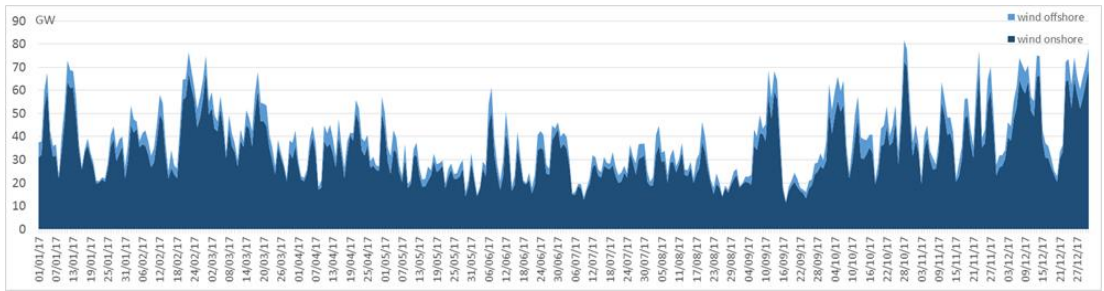

Figure 6. Upper graph: daily wind generation in 2017 in the European Union. Lower graph: Daily wind generation and demand in 2020 in the European Union and the United Kingdom (Source: WindEurope).

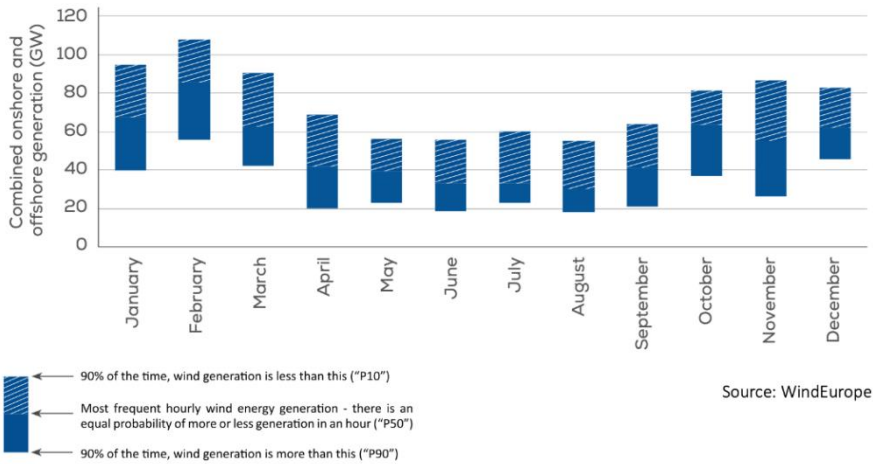

Figure 7. Spread of hourly generation in 2020 in the European Union and the United Kingdom. For each month, the median, P10, and P90 values are shown (Source: WindEurope).

In 2017, the minimum wind generation was registered on June 2nd at 10.00 hours, 7.8 GW (5% of installed wind capacity) and maximum on October 28th at 20.00, 88 GW (52% of installed wind capacity). The capacity factor was on average 22.3%. Offshore wind generation is more evenly distributed across a larger spectrum of values, with values generally larger than for onshore (Figure 8). Since offshore capacity is much smaller and more concentrated mainly in North Sea, the minimum was 0% and maximum 75% of the installed capacity, compared to onshore wind with values between 10 and 30%.

In 2020, one year wind output in Europe (land-based and offshore combined) ranged from the low of 8.7 GW on August 27 at 08:00, to the high of 109 GW on March 13 at 13:00. The record production was achieved on February 10 when the average capacity factor was 60% for the whole fleet for the entire day. Wind met 24% of the electricity demand for the entire month of February (16.6% over the whole of 2020 for EU plus GB).

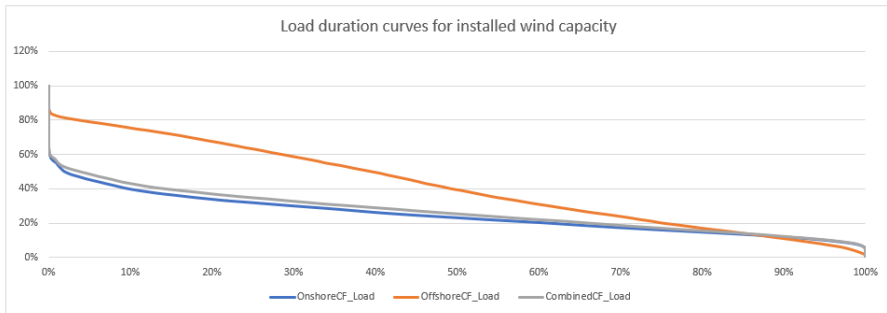
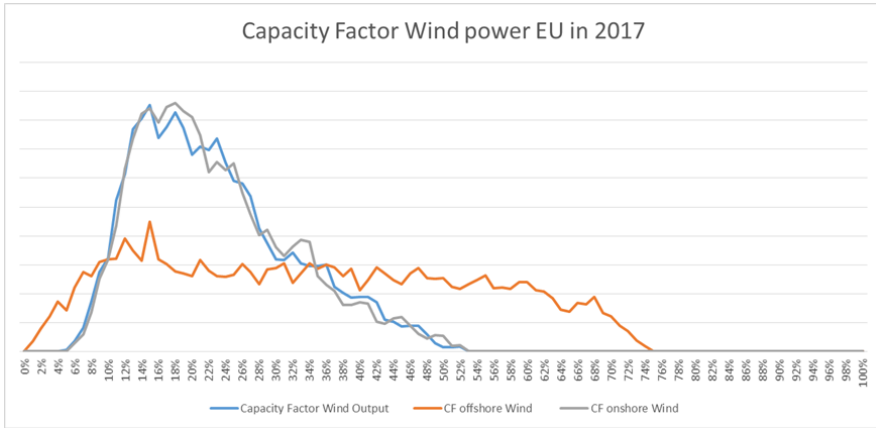

Figure 8. Probability curves for capacity factors (average generation relative to installed rated capacity) based on hourly wind generation data in 2017, and duration curves for hourly generation in 2020 (Source: WindEurope).

### *Impacts of turbine technology on variability*

In addition to the geographic distribution of installations, the installed technology impacts wind energy variability. Using higher hub heights and lower specific power turbines increases capacity factors, and although the variability in megawatt terms increases, relative variability tends to decrease (Koivisto et al., 2019). This means that the same amount of annual TWh can be generated with lower variability—and also with lower installed capacity.

The chosen wind technology also impacts storm behaviour, which can be especially important for extreme ramp rates in offshore wind in areas with high installation density (Murcia Leon et al., 2021).

### Periods of low wind generation

For larger areas, the wind always blows somewhere. This has been proved by the hourly data available for Europe; however, there can be low wind periods when the generation is much lower than average.

Periods of low wind for the European Union were analysed by WindEurope for different thresholds of low wind for 2017 data (Figure 9). The installed capacity used for this analysis was from the end of 2016, which could cause a slight overestimation of the capacity factors because the installed capacity at end of December was 10% higher than at the beginning of January. There was only one event, during 2 hours, when the total wind generation was less than 5% of installed capacity. During 17 hours, wind generation was less than 6% of installed capacity; this took place during individual events shorter than 5 hours. Wind was less than 10% of its installed capacity during 430 hours. Most of the events lasted less than 10 hours. The longest one lasted for 38 hours.

For year 2019, there was only 1 hour less than 5% capacity, a maximum of 13 consecutive hours less than 8% of capacity, and 34 consecutive hours less than 10% of capacity.

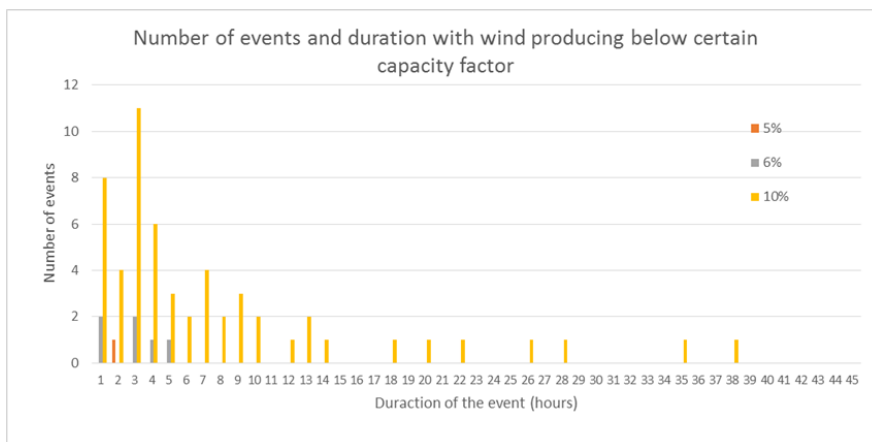

Figure 9. Number of events and duration with wind producing below a certain capacity factor in Europe in 2017 (Source: WindEurope).

### Extreme ramps in storms

Extreme ramps in storms have been recorded in:

- Germany: The largest downward ramp, of 12% of installed capacity in an hour, was recorded during a storm on February 14, 2014. The largest ramps were recorded from 3 years of data: -5.8% to +5.1% of installed capacity within 15 minutes, -12.5% to +11.9% within 1 hour, and -38% to +45% within

5 hours. In 2019 and 2020, the maximum hourly ramps were less than 10% of installed capacity.

- Portugal: The most severe wind power ramps observed in 2019 were -6.5% and +6.9% for 5 minutes; -16.6% and +19.5% for 1 hour, and -48.7% and +55% within 5 hours. These were lower than the historically observed ramps of -19.2% to +24.6% (within 1 hour) and -50.6% to +63.6% (within 5 hours). Source for data: TSO REN.
- Denmark: System operator Energinet reported the largest storm event in October 2013 when wind power decreased from 3000 to 1000 MW in less than 2 hours (25% of capacity in 1 hour and 6% of capacity in 15 minutes).
- Spain: The largest hourly ramps in 2019 were +15.7% and -17.9% of installed capacity and for 10-minute ramps +4.4% and -4.0% of installed capacity. The largest hourly ramps in 2018 were +15% and -13.4% of installed capacity.

For Germany, the extreme ramps are from more than 3 years of data (28575 MW of wind power in January 2012 to 38104 MW in April 2015). The largest ramps and forecast errors occurred during the 130 storm events recorded during that time.

Specific storm shutdown technologies can be applied to lower expected ramp rates during storms—this would impact especially large concentrated areas of (off-shore) WPPs (Murcia Leon et al., 2021).

### **2.1.2 Smoothing impact and metric for system size and wind dispersion**

Checking the variability and smoothing impact in the data might be necessary to make sure that the input data are not over- or underpredicting the variability. This could be when up-scaling existing wind generation data or when simulating future wind generation from sites not yet deployed.

Kiviluoma et al. (2014) calculated an index for wind power variability for multiple power systems. The index is a composite of wind power ramps in three different timescales at three ramp exceedance levels. A regression model using wind power capacity factor and mean distance from the center of wind power capacity was able to explain most of the variability (Figure 10).

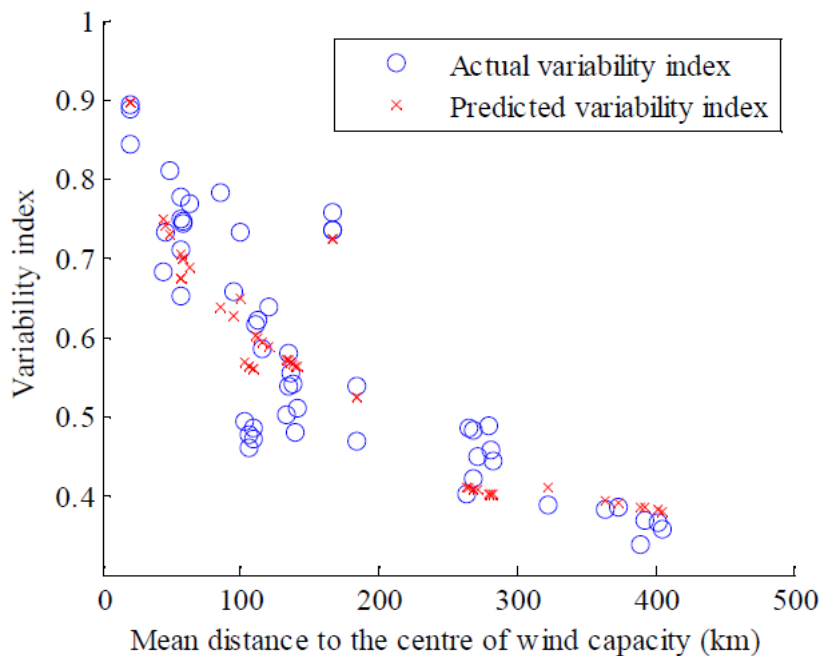

Figure 10. Realized variability index (blue circles) and predicted variability index (red crosses) with leave-one-out using capacity factor, mean distance, and logarithm of mean distance as the dependent variables (Source: Kiviluoma et al., 2014).

The equivalent system radius (REQ) is proposed in Olauson et al. (2016) for a metric for system size and WPP dispersion. The idea is that a wind power system can be represented by a uniform wind power disk with the same variance as the actual system, assuming an exponential decline of correlation of output with separation distance (Figure 11).

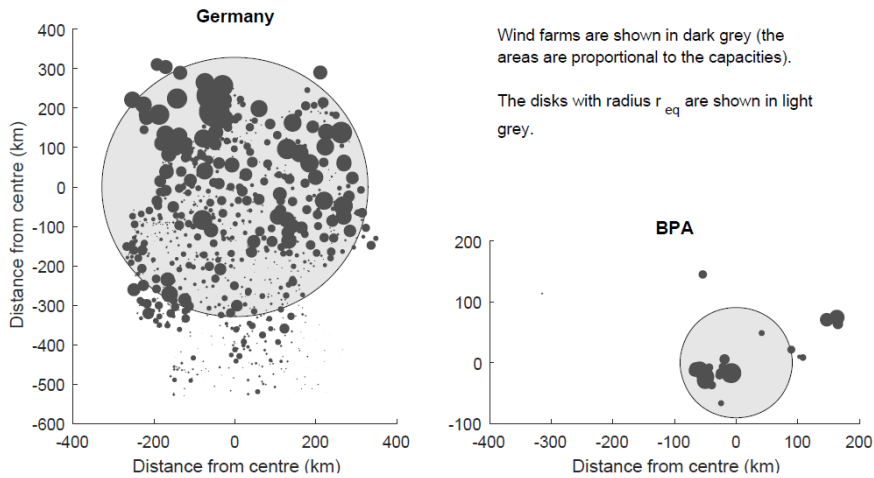

Figure 11. Illustration of the equivalent system radius (REQ) for Germany and BPA. Note that BPA (Bonneville Power Administration in the US) power plants are concentrated in a relatively small area, which gives a small REQ compared to the total system dimensions. In particular, the small power plant at (-300,100) does not impact REQ much (Source: Olauson et al., 2016).

### 2.1.3 Variability from simulated wind energy generation

Reanalysis data sets are routinely used to model wind power for integration studies. As real measured data for power system-wide wind power started to emerge, it was shown in 2016 that estimated data had higher variability than real data: Using wind speed data from reanalysis (Germany) or measurements (Netherlands) resulted in higher hourly variability than actual, measured, large-scale wind power production data, even if using well-dispersed data to simulate large-scale wind power production (Kiviluoma et al., 2016).

However, the new European reanalysis ERA5 from the European Centre for Medium-Range Weather Forecasts (ECMWF) performs considerably better than the often-used Modern-Era Retrospective analysis for Research and Applications, Version 2 (MERRA-2), both for countrywide generation and for individual wind turbines (Olauson et al., 2016). On average, the errors are approximately 20% lower for ERA5, but the reduction varies between countries.

In the United States, the National Renewable Energy Laboratory (NREL) uses a combination of the National Solar Radiation Database (NSRDB) for solar time-series data and the Wind Integration National Dataset (WIND) Toolkit for wind data (<https://www.nrel.gov/grid/wind-toolkit.html>). Both provide coverage for a number of years over the continental United States.

In France, Jourdi er (2020) compared simulations of wind generation using different reanalysis products and models: MERRA-2 from the National Aeronautics and Space Administration and ERA5 from the ECMWF, more high-resolution regional



ones (COSMO-REA6 reanalysis from the German Weather Service DWD and the AROME numerical weather prediction model from Météo-France), and the New European Wind Atlas (NEWA) mesoscale data. A comparison of modelled and measured wind-power production for France and different areas in 2015 is shown in Figure 12. Figure 12(a) shows, for each region (identified by marker style) and each model (identified by marker color), the bias in percentage of the installed capacity (model – observation, on the y-axis) versus correlation coefficient (on the x-axis) of the 30-minute wind power time series. Figure 12(b)–Figure 12(e) show average diurnal cycles of the observed (in black) and modelled (in color) wind-power capacity factors for all of France (b), Brittany (c), center-summed with Ile-de-France (d), and Occitanie summed with PACA (e). In Figure 13, bias (model – observation) is in average power expressed in percentage of the installed capacity. The data year is 2015, and loss factor is 15%.

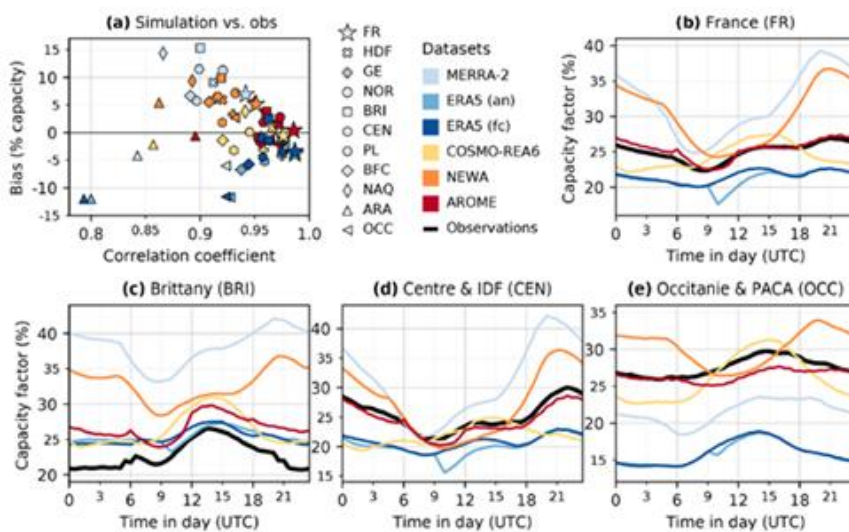

Figure 12. Comparison of modelled and measured wind power production for France and different areas in 2015 (Source: Jourdier, 2020).

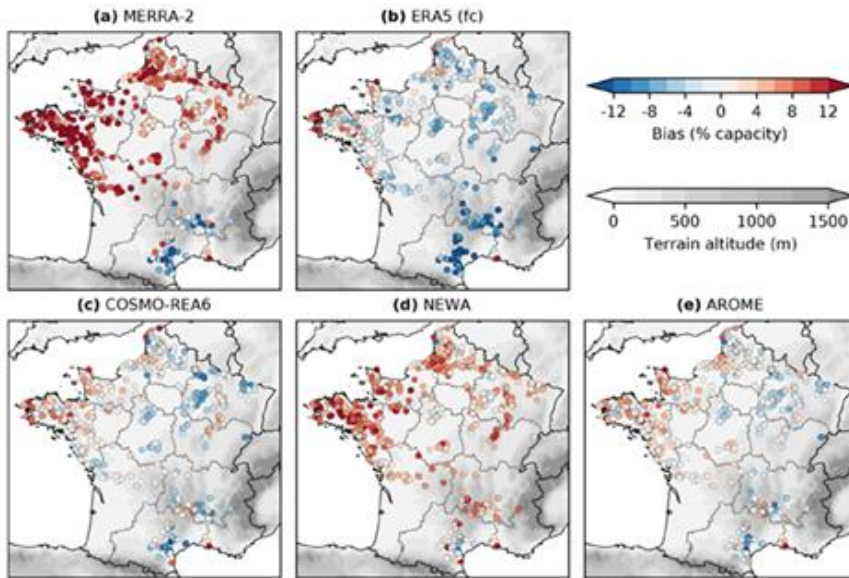

Figure 13. Local biases of wind power production simulations based on (a) MERRA-2, (b) ERA5 (forecasts), (c) COSMO-REA6, (d) NEWA, and (e) AROME compared to DSO database at city scale (Source: Jourdier, 2020).

Time-series simulation tools are especially useful for future scenarios with varying wind and solar installations. The temporal and spatial interrelations of wind and solar at different timescales need to be captured. In addition, it is important to use renewable generation time series in neighbouring areas with correct correlation. The Technical University of Denmark wind energy tool Correlations in Renewable Energy Sources (CorRES) is generating joint wind and solar time series over a large transcontinental system, Figure 14 (Nuño et al., 2018). This is used for long-term planning of the transcontinental European power system in the Ten Years Network Development Plan published biannually by ENTSO-E.<sup>2</sup>

For storm shutdowns, especially for large, concentrated, offshore WPPs, the most important timescales can be higher frequency than hourly, and accurate modelling of subhourly ramp rates is needed (Koivisto et al., 2020a).

<sup>2</sup> <https://tyndp.entsoe.eu/>

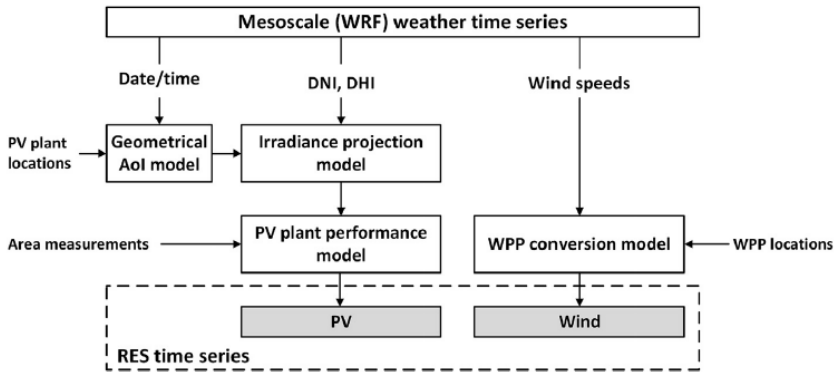

Figure 14. Schematic diagram for the PV power and wind power time-series generator CorRES (Source: Nuño et al., 2018).

#### 2.1.4 Wind and solar complementarity

There is considerable complementarity in wind and solar energy—low solar resource days can have high wind resource and vice versa. An example from France is shown in Figure 15.

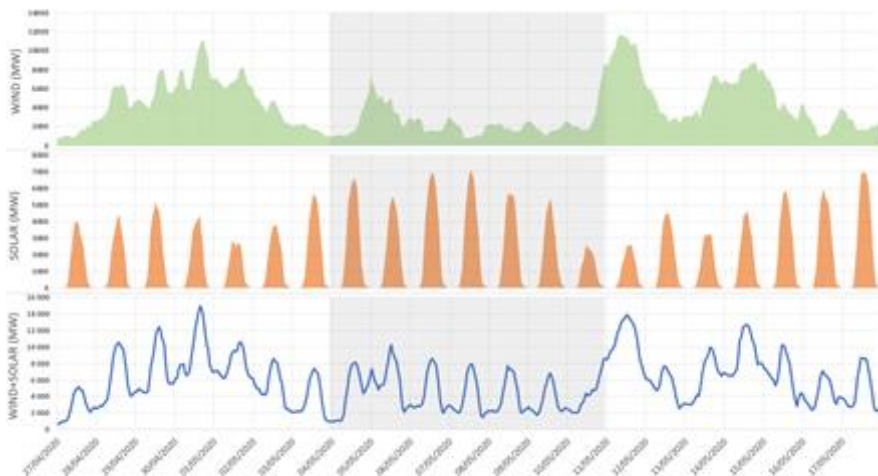

Figure 15. Example of wind and solar time series for 3 weeks during 2020 in France (Data source: ENTSO-E Transparency: <https://transparency.entsoe.eu/>).

The complementarity of wind and solar energy generation can be used to improve their capability to meet demand. Optimized shares of wind and solar for power systems that consider the variability of load and net load have resulted in 2020 MW

solar PV + 3560 MW wind in the Portugal case, Figure 16 (Couto & Estanqueiro, 2020).

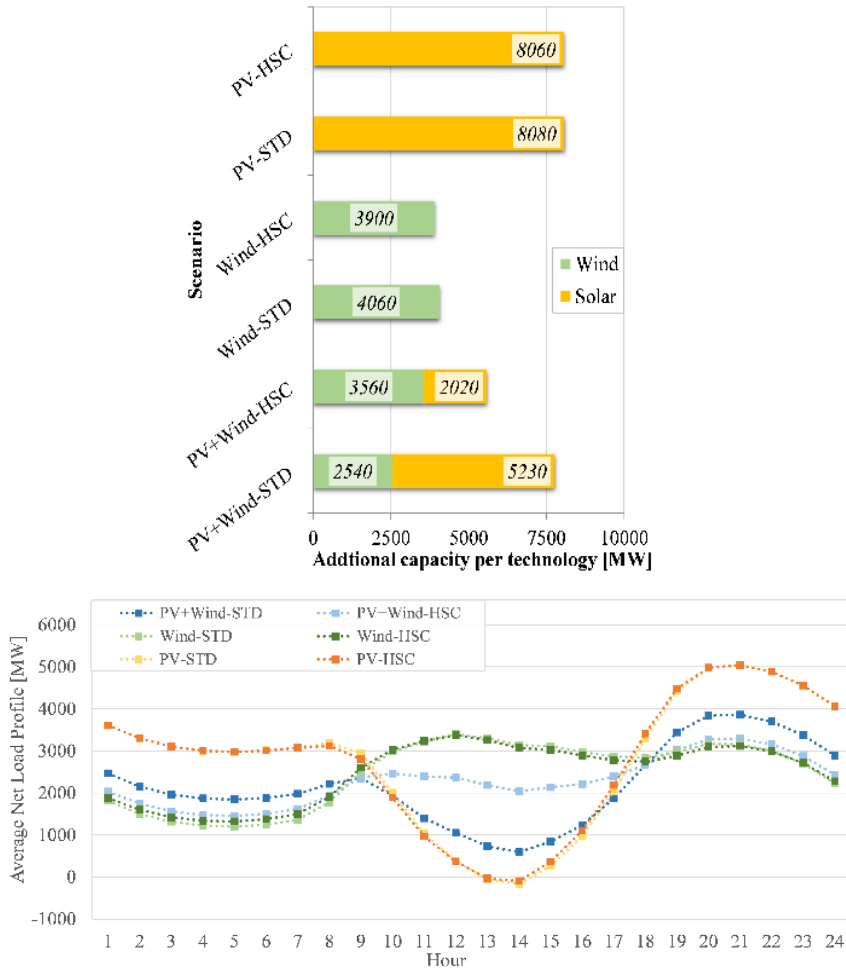

Figure 16. Optimizing the share of wind and solar for maximum complementarity, example from Portugal: top: identification of the wind/solar PV power capacity in each scenario and bottom: daily profile for all scenarios for a 5% annual energy surplus. STD and HSC represent the minimization criterion, net load annual variability based on the annual standard deviation and the 1-hour net load step change standard deviation, respectively (Source: Couto & Estanqueiro, 2020).

## 2.2 Uncertainty

As with variability, for power system operation, extreme forecast errors are important for the operating reserve setting. Forecasting ramping events as well as low wind and solar occurrences are useful. Simulated forecasts are needed for power system simulations when considering that future forecast errors will be smaller than today—and when simulating a wind power fleet sited in new areas where existing data are not available.

The uncertainty in wind power production will be reduced for aggregated, dispersed wind power (Figure 17). Future wind power will see a reduction in uncertainty as more accurate forecasting methods are developed and operational practices evolve toward faster decisions with better forecast accuracy. For short time horizons, accurate and representative measurements in real time, directly from WPPs or weather stations, will improve accuracy.

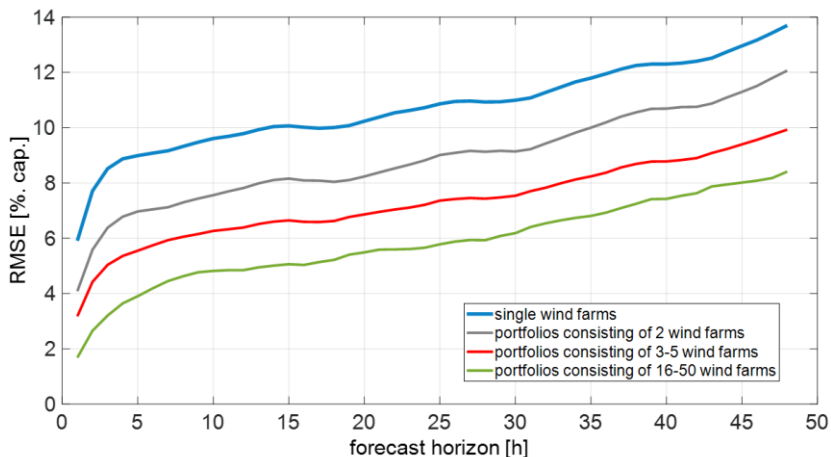

Figure 17. Example of aggregation benefits for wind power forecast errors from Germany. The relative forecast error for all forecast horizons (measured as root mean square error) are reduced when more WPPs are aggregated (Source: Fraunhofer IEE, adapted from Dobschinski, 2014).

### 2.2.1 Now-casting for observability

Observability is another challenge for distributed generation and will mean that part of the generation will need to be forecasted in real time. Due to cost considerations or technical requirements at the time of their construction, individual PV panels, first-generation wind turbines, or even some small hydro units often lack any real-time metering device. In Germany, the transmission system operators (TSOs) directly monitor only a small part of the wind (and solar) generation, and a large part of the

generation has been estimated in real time using now-casting (Biermann et al., 2005).

In Spain, the requirement for all small-scale power producers to report through dispatch centers has led to more than 98% of wind and solar being monitored in real time. (Holttinen et al., 2011). The system operator REE receives, through the Control Centre of Renewable Energies (CeCre), the telemetry of 98.6% of the wind generation installed, of which 96% is controllable (able to adapt its production to the given set point within 15 minutes). The telecommunications deployment to almost 800 wind power plants spread throughout Spain has been achieved as a result of the aggregation of all the distributed resources of more than 10 MW in renewable energy control centers and the connection of them with the Control Centre of Renewable Energies. Supervising and controlling the wind generation in real time allows for maintaining the quality and security of the electricity supply while maximizing renewable energy integration, reducing curtailments.

In France, 81% of wind generation is directly measurable in 2021. This also means that short-term forecasts are largely based on a large amount of real-time monitoring and are therefore very accurate. For solar PV, however, it is not possible today to measure or estimate real-time output for more than one-third of the installed capacity in France. When a significant correlation between the plant output and other monitored plants, located nearby, has been identified, it is possible to estimate the real-time generation without directly connected measurement devices. If it is not possible to estimate a generator's output, the real-time generation is usually considered to match the most recent forecast. In France, this is the case for most small-scale, distributed PV generation units, which are treated as a whole. The use of imaging satellites, which provide estimates of the solar radiation at ground level with a spatial resolution of approximately 5 km by 5 km over France, refreshed every 15 minutes, can be combined with machine learning methods, or "physical" models, to allow for quality estimation of local PV generation in real time in the future. Combining satellite images with cloud motion vector methods would improve very short-term PV forecast adequacy (Kasmi, 2021).

### **2.2.2 Extreme forecast error events**

Extreme forecast errors give rise to an increased need for operating reserves; see Section 5.1. Forecast errors are usually lower on low wind days, and extreme errors often coincide with storm events.

In Germany, the forecast errors for the 3-year time period from 2012–2014 show a seasonal dependency with larger or more frequent errors during colder months and a mean absolute error of 2.3% of installed capacity. Subjective analysis on the synoptic scale revealed that in 60.2%, of the 88 days with large wind power forecast errors, a cyclone or a trough moved over the North Sea, the Baltic Sea, or directly over Germany (Figure 18). The maximum observed day-ahead forecast errors were -19.2 and +21.5% of installed wind capacity (the 0.01% and the 99.99% quantiles -18.5% and 18.3%) (Dobschinski et al., 2016). The large error events have been

balanced by a continuous intraday trading based on additional intraday power forecasts that use recent wind power measurements in addition to weather forecasts.

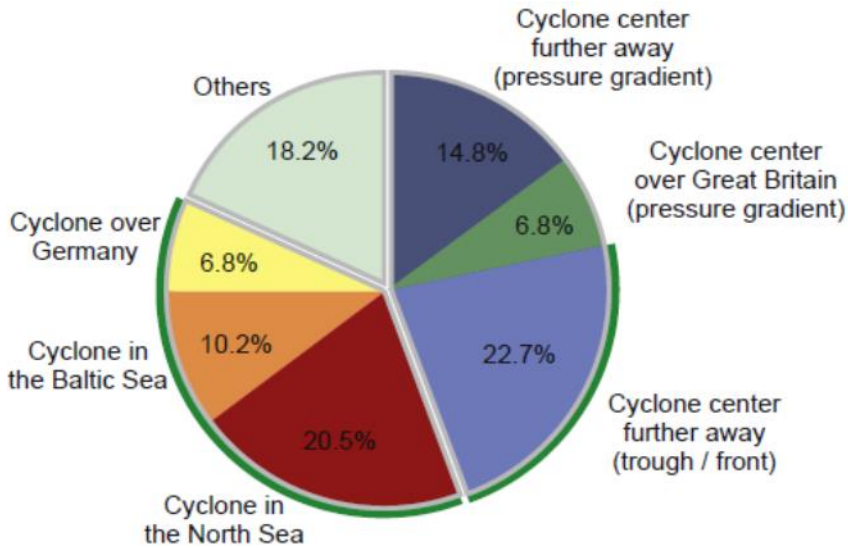

Figure 18. Subjective evaluation of synoptic scale weather elements during dates with large wind power forecast errors. The outermost green lines label the cases where small-scale, low-pressure systems or troughs could be linked with large forecast errors (60.2%) (Source: Steiner et al., 2017).

### 2.2.3 Ramp forecasting

**In Germany**, the project EWeLiNE developed an automated cyclone-detection algorithm to recognize the challenging weather situations described in Section 2.2.2 (Steiner et al., 2017). The cyclone detection is based on mean sea level pressure and uses the Laplacian of the pressure field as a proxy for the quasi-geostrophic relative vorticity to indicate areas of cyclonic influence. Subjectively chosen thresholds for curvature values as well as for spatiotemporal movement complete the automated cyclone-detection algorithm.

**In Portugal**, the wind power ramps driven by windstorms and cyclones were analysed in (Lacerda et al., 2017). In this work, the authors applied common meteorological cyclone- and windstorm-detection algorithms to understand the underlying role and key features (e.g., location, intensity, and trajectories) of these phenomena in triggering wind power ramps (Figure 19).

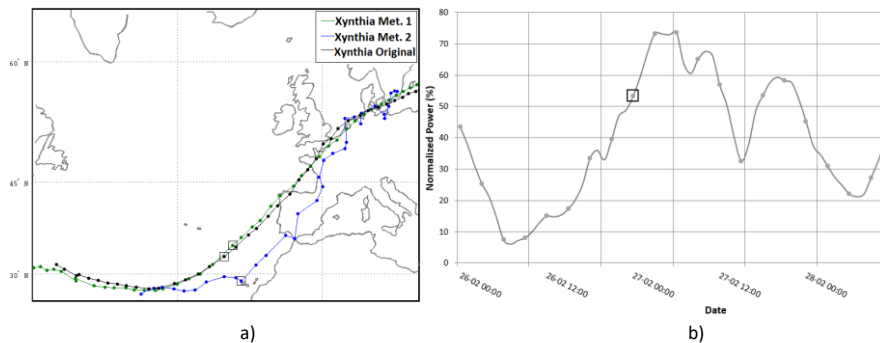

Figure 19. (a) Resulting trajectories for Xynthia storm with a cyclone- (green) and windstorm (blue) detection algorithm implemented by LNEG, official trajectory (black); (b) aggregate observed normalized wind power production in Portugal. Source: adapted from Lacerda et al., (2017).

## 2.2.4 Forecasting low wind and solar events

Forecasting the decrease in wind speeds, especially for longer low-wind-speed periods, is important for the system. In Li et al. (2020), it was shown that the wind speed decline seen during a so-called Dunkelflaute event (simultaneous low wind and solar energy production) was well captured in April 2018 in the Netherlands by the mesoscale Weather Research and Forecasting (WRF) model predictions when it was initialized less than 3 days in advance driven by the Global Forecast System (GFS) operational data. Another pair of Dunkelflaute events that occurred less than 1 week apart in Belgium during 2017 were studied to see how well prediction of those events could be made up to 10 days in advance. The first period was well captured by WRF runs but needed a WRF model run (WRF–GFS+) initialized much closer to the second event to predict its timing and duration (Figure 20, Li et al., 2021), confirming a prediction horizon of only approximately 3–4 days. Through validation using a variety of measured data covering land-based and offshore areas, wind speed is shown to be more predictable than cloud cover in these two case studies. For solar, more validation work, potentially involving satellite remote-sensing-data, is needed.



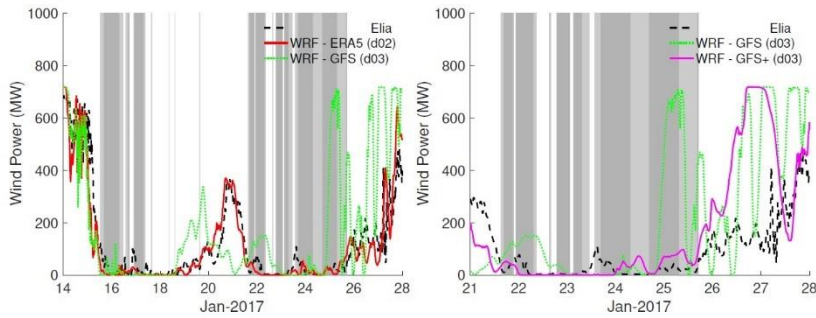

Figure 20. Measured and simulated wind power production data during Dunkelflaute periods of January 14–28 (left panel). The simulated results from the WRF–GFS+ run, initialized on January 21, are shown in the right panel. The daytime Dunkelflaute periods are represented with lightly shaded gray regions. The weak wind conditions, occurring during nighttime hours (no solar power generation), are demarcated by a darker shade. The measured wind power data are obtained from Elia.

### 2.2.5 Improvements to forecasting

The forecast methods and numerical weather prediction are still improving. In Spain, examples of average absolute forecast errors for different (day-ahead) forecast horizons are shown in Figure 21. The average errors for each year of operation still show a reducing trend: approximately 20% improvement in mean absolute error in 5 years, leading to values for 24-hour-ahead forecasts of approximately 2% of the installed total wind power capacity.

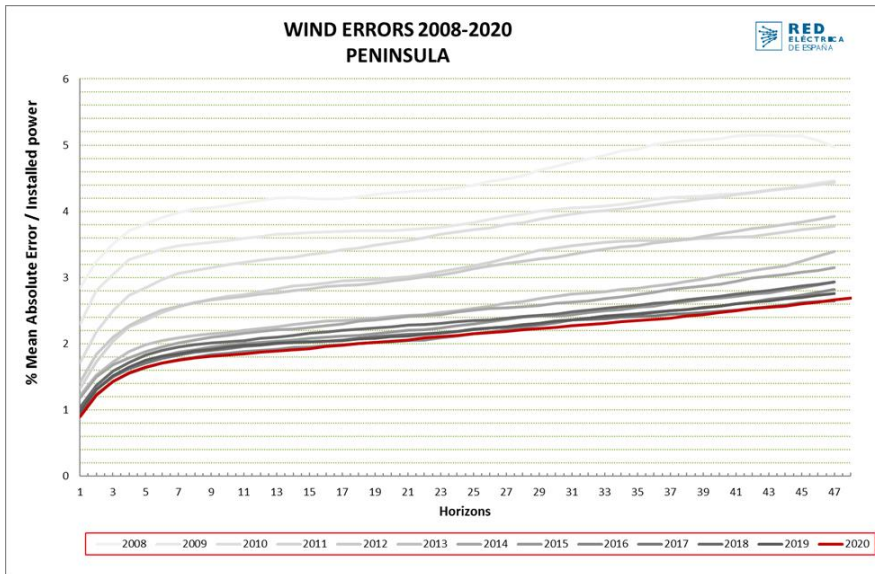

Figure 21. Forecast accuracy improvement: average forecast error for different look-ahead horizons from recent years of operation, example from Spain (Source: Spain REE).

With higher shares of wind energy, there will be involuntary or voluntary curtailments in WPPs due to system constraints or market prices (zero or negative). If this is not properly considered, it could be seen in forecast errors. For example, in Figure 22, the forecast of “available generation” was good but producers reduced voluntarily output from their WPPs.

## Impact of curtailments and other reductions on forecasting Example: Storm front Herwart, October 28/29, 2017

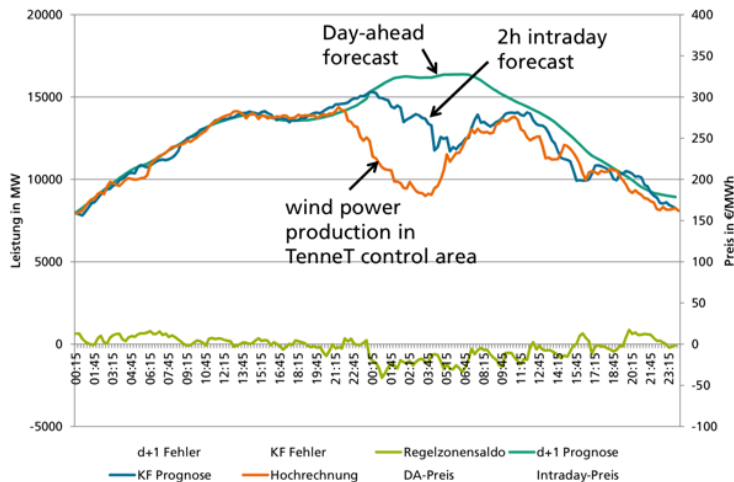

Figure 22. Impact of curtailments, storm cutoffs, and negative prices on forecasting accuracy (Source: Fraunhofer IEE Gridcast).

To optimize weather and power forecasts, the following points for improvements have been identified with respect to the numerical weather prediction (Dobschinski et al., 2016; Siefert et al., 2017):

- Improvement of the initial state of numerical weather prediction models by assimilating newly available data such as wind turbine and PV system power data or wind speed measurements at hub height
- Improved physical parameterizations of the relevant atmospheric processes within the numerical weather prediction
- Improved post-processing procedure of the forecast results, called model output statistics, which consider measurements
- Improved ensemble prediction systems
- Improved calibration of the probabilistic forecasts.

The conversion of wind to power must be considered in the assimilation of wind and PV data to ensure that this process does not deteriorate the conventional weather and power forecast skills. With respect to power forecasts, the following improvement potentials have been identified:

- Better basis of wind and solar power data that comprise more locations and consider the status of the power plants (e.g., in operation, power reduction, maintenance)
- Using off-site measurements as input into the power forecast models
- Classification of weather situations

- An improved aggregation of wind and solar power plants to larger regions
- Improved mapping of wind and solar power plants to grid nodes
- Using calibrated probabilistic forecasts to assess the forecast uncertainty in advance
- Improved methods to convert ensemble information into probabilistic forecasts
- Improved methods to combine different forecast models with respect to the existing weather situation and network state.

The IEA Wind TCP Task 36 on Forecasting for Wind Energy (<https://iea-wind.org/task-36/>) highlights how the use of forecasts depends on the use case. In some cases, improved accuracy of the forecast might result from getting the right forecast for the right application. There is also work on the use and improvement of seasonal forecasts.

### **2.2.6 Forecast error data simulations**

Simulated forecasts are needed for power system simulations when considering that future forecast errors will be smaller than today—and when simulating a wind power fleet sited in new areas where existing data are not available. Simulating synthetic forecasts with purely statistical methods has challenges, especially when several forecast horizons are needed, and also when combining them with the real-time wind generation.

In the EU project Optimal System-Mix of Flexibility Solutions for European Electricity (OSMOSE) D2.1, a new methodology for simulating forecast errors was used, reflecting the different fundamental characteristics of wind, solar, and load (OSMOSE D2.1, 2019). The various look-ahead times corresponding to the sequences of markets and operational decisions is important to capture (Figure 23). The time series produced for the market simulations should converge to the infeed time series, which mimics real time behavior; hence, the future forecast errors are simulated and added on top of the infeed time series, which has been generated by another approach, typically using meteorological data (Figure 24). The method relies on the availability of a high amount of forecast error observations, measured at different look-ahead times. For modelling forecast paths, this results in a multivariate formulation of the corresponding distribution function, implemented using a copula-based approach.

The methods for assessing forecast errors have proven generally applicable; however, further research is needed on calibration and ability to accurately model geographic correlations of forecast errors between market zones.

In Olason (2018), generation is simulated from reanalyses, and up to 1-week-ahead synthetic forecasts are based on meteorological “re-forecasts” and some statistical post-processing.

Miettinen et al. (2020) proposed a method for estimating distributions of forecast errors. It is based on the area size and dispersion of WPPs in the area.

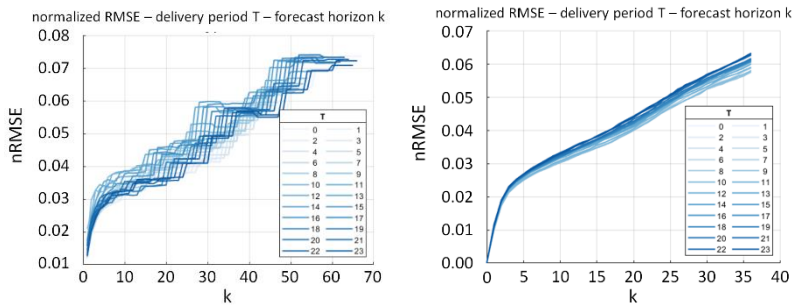

Figure 23. Normalized root mean square error (nRMSE) on wind generation in France for observed (left) and simulated forecasts paths (right) for every delivery period and forecast horizon (Source: OSMOSE D2.1, 2019).

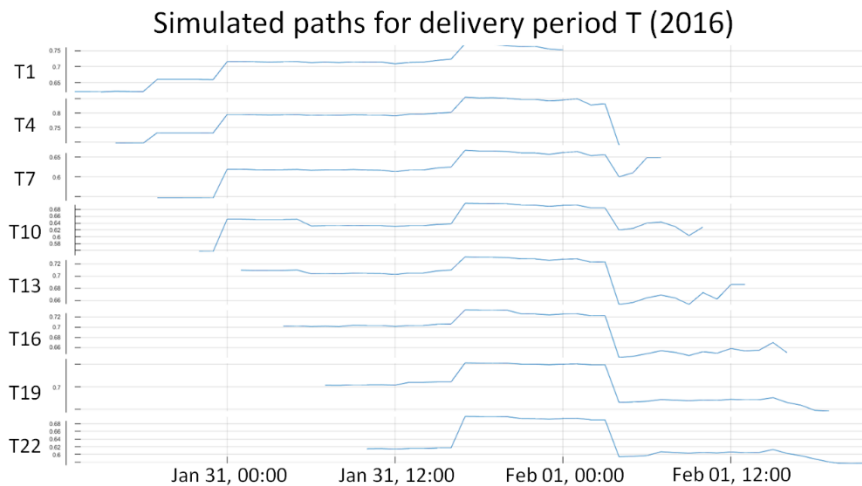

Figure 24. Simulated forecast paths for a single scenario and adjacent delivery periods (Source: OSMOSE D2.1, 2019).

### 3. Transmission planning

Technically, the secure integration of renewables will need substantial grid development efforts as one condition, in addition to stability, system adequacy, and operational reserves, as discussed in sections 4 and 5 (IEA-RTE, 2021; EU-Sysflex D2.1, 2018). The need for reinforcements will depend on the existing grid and location of the wind resource exploited. New tools, uncertainty analyses, and regional collaboration will be needed for future systems with higher shares of wind power (Statnett, FG, Energinet, SvK, 2016). A trend toward larger installations at sea, offshore grids, and hybrids such as energy islands are affecting many countries and power systems and will add to the grid planning challenge. Decarbonizing other energy sectors and sector coupling is expected to further increase the importance of offshore wind in the green transition.

Studying a future year, new transmission will be required for all future wind scenarios, often also including the reference case (such as for the U.S. Eastern Interconnection; EWITS, 2010). Transmission helps reduce the impacts of the variability of wind, helps increase the reliability of the electric grid, and helps make more efficient use of the available generation resources. Although costs for aggressive expansions of the existing grid are significant, they comprise a relatively small piece of the total annualized costs in the scenarios studied (EWITS, 2010). In comparing the alternative transmission build-out scenarios, a common “core” of transmission corridors can be identified, indicating that these corridors represent a robust selection of lines that will be useful regardless of the future scenario that will evolve.

Grid reinforcement costs from national studies have been published before as a summary graph (Holtinen et al., 2009); however, investments in the transmission grid have multiple benefits. In addition to reducing bottlenecks, they will improve system flexibility and the security of supply. This means that the costs should not be fully allocated to wind power. In previous studies, the effort to allocate costs among different needs was made only in Portugal. Quantifying the benefits for reliability and added flexibility is difficult, which has resulted in TSOs highlighting only estimates for main benefits for the proposed grid reinforcements: The European TSOs combined efforts for the Ten-Year Network Development Plan (TYNDP) depicted on the general level the parts of the grid that will be needed for renewables/markets/security (Holtinen et al., 2016). As shown in the National Development Plan 2020 in Italy (Terna, 2020), most lines contribute to all three key drivers: decarbonization, market efficiency, and security of supply (Figure 25).

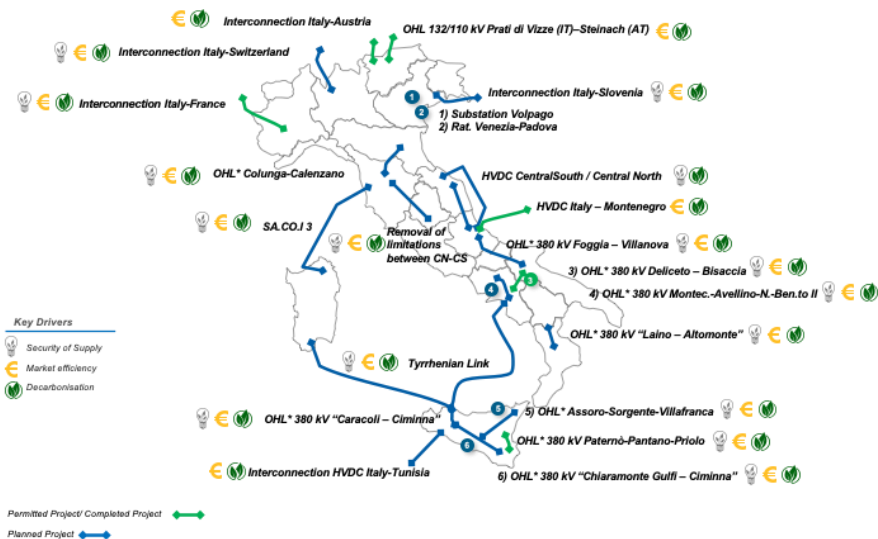

Figure 25. Planned (in blue) and already permitted (in green) transmission grid investments in Italy. Key drivers for each investment are marked: decarbonization, market efficiency, and security of supply (OHL: overhead lines) (Source: Terna, 2020).

### 3.1 Regional transmission planning

Regional transmission planning shows the benefits of expanding and reinforcing the transmission grid to neighbouring regions and power systems. There is clear benefit over costs in building more of the grid, which is realized through sharing generation resources and flexibility across regions. This will be even more pronounced with high shares of wind and solar, shown by both European and American studies.

In recent U.S. studies, an extrahigh-voltage super grid has also been shown to be cost-effective (NREL, 2020), to move massive amounts of remote renewable resources very long distances across synchronous zones to load centers. In the European research project e-Highways, an overlay macro grid was not seen as necessary, and the proposed architectures are based on integrating the present pan-European transmission grid (Sanchis et al., 2015).

Benefits for transmission expansion and reinforcement, such as added flexibility for power systems, is also discussed in Section 6.6.

#### 3.1.1 European grid scenarios for high shares of wind power

Transmission planning in Europe has evolved toward regional, European-wide efforts by ENTSO-E. The TYNDP is published every second year. They are conducted with intense stakeholder involvement related to all phases: (1) the scenario development, (2) the identification of system needs, and (3) the cost-benefit analysis. In

all phases, the methodologies used have evolved over time. Reports, interactive maps, and interactive data tools are published in ENTSO-E TYNDP (2020).

The “identification of system needs” process identifies needs, which are translated into infrastructure corridors between the European countries. Other solutions—such as storage, demand-side management, smart grid solutions, and sector integration solutions—might be possible as well, but they have not been directly assessed. The identified corridors have the highest value, meaning that their benefits are higher than their costs. For the most robust expansion plans, the lines would have higher benefits in several future scenarios of demand and generation (Figure 26, ENTSO-E TYNDP, 2020).



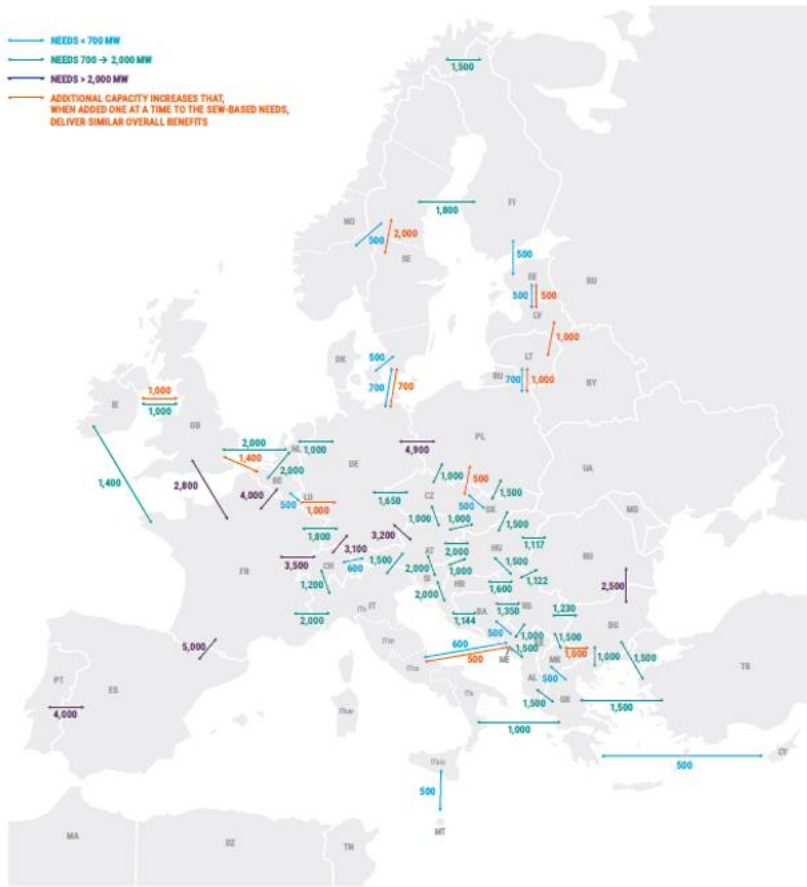

Figure 1.5 – Needs for capacity increases identified in the 2040 horizon, additional to the 2025 network (SEW-based Needs 2040) and additional network increases included in grid solutions that were only slightly more expensive than the SEW-based Needs 2040\*.

Figure 26. The most robust Europe-wide grid architecture for a low-carbon future (Source: “Completing the Map 2020 – Power System Needs in 2030 and 2040; EN-TSO-E, Nov 2020).

### 3.1.2 Regional grid studies in North America

The North American Renewable Integration Study (NARIS) analyzed pathways to modernize the North American power system through the efficient regional planning of transmission, generation, and demand. The interconnection of the U.S., Canada, and Mexico power systems was examined from planning through operation and balancing at 5-minute resolution. Coordinated grid planning and operation, cross-border transmission, grid flexibility, and other strategies and technologies to enable

high penetrations of renewables were assessed. NARIS was the largest study of its kind, which meant that it developed state-of-the-art methods, scenarios, and data sets—which are also relevant for future analysis (Brinkman et al., 2021).

The main findings for transmission planning are that regional and international cooperation can provide significant net system benefits through 2050. Increasing electricity trade between countries can provide from \$10 billion to \$30 billion net value to the system. Interregional transmission expansion achieves up to \$180 billion in net benefits. Although these values are a small percentage (less than 4%) of the total \$5 trillion to \$8 trillion total system costs (which include all capital and operating generation and transmission system costs), transmission plays an important role in minimizing costs, and it is one of the main flexibility providers for the future system operation, Figure 27.

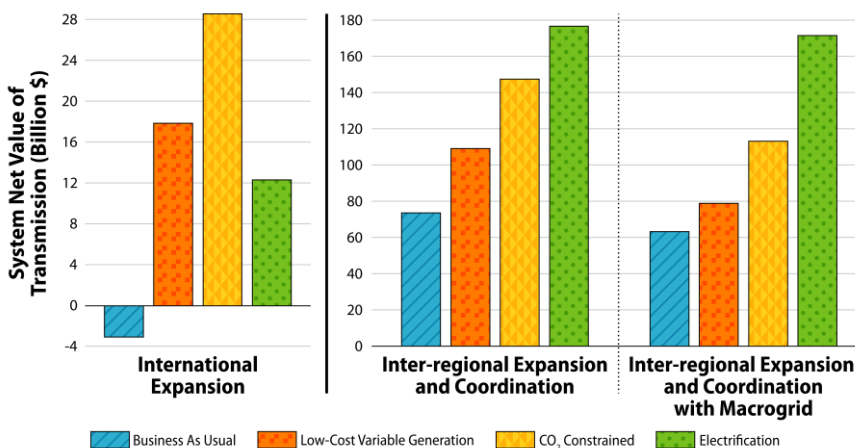

Figure 27. Continent-wide net value of transmission expansion for the four scenarios in the NARIS study (Source: Brinkman et al., 2021).

The Interconnection Seams Study conducted by NREL for the U.S. Department of Energy (NREL, 2020) examined the potential economic value of increasing electricity transfer between the U.S. Eastern Interconnection and the U.S. Western Interconnections using HVDC transmission and cost-optimizing both generation and transmission resources across the United States. The results show benefit-to-cost ratios that reach as high as 2.9, indicating significant value to increasing the transmission capacity between the interconnections under the cases considered, realized through sharing generation resources and flexibility across regions. Studies from independent system operators further demonstrate that benefits of more regionally planned projects would greatly exceed costs (MTEP, 2019; SPP, 2020)

The NREL Seams study laid the foundation for investigating an HVDC overlay for the U.S. grid, augmented by HVAC links. The idea is driven by the need to move massive amounts of remote renewable resources very long distances across

synchronous zone seams to load centers in an economic and reliable fashion. There is good agreement that the existing transmission infrastructure is inadequate for the purpose and that it will need to be expanded by a factor of 2 or more to achieve the ambitious goals of the Paris climate agreement and the policy goals of the new U.S. administration.

Subsequent transmission plans for U.S. clean energy scenarios include major intraregional expansions in the wind-rich areas of the regional networks of the Southwest Power Pool (SPP) and the Midcontinent Independent System Operator (MISO); interregional ties between SPP, MISO, and SERC (the Southeast Reliability Corporation); and the strong east-west connections from MISO and SPP to PJM (Brown & Botterud, 2020). Energy Systems Integration Group (ESIG) white paper (ESIG, 2021a) reviewed a decade’s worth of transmission expansion studies. It revealed the essential role of transmission expansion in supporting decarbonisation goals at lowest cost. Building on the Seams study scenario, individual links are added as part of a coordinated national plan so that over time a continental-scale HVDC overlay grid is constructed. A coordinated, nationwide planning process is recommended, introducing designated renewable energy zones that receive priority development, and the macro-grid design plan to unite the country’s power systems. (Figure 28).

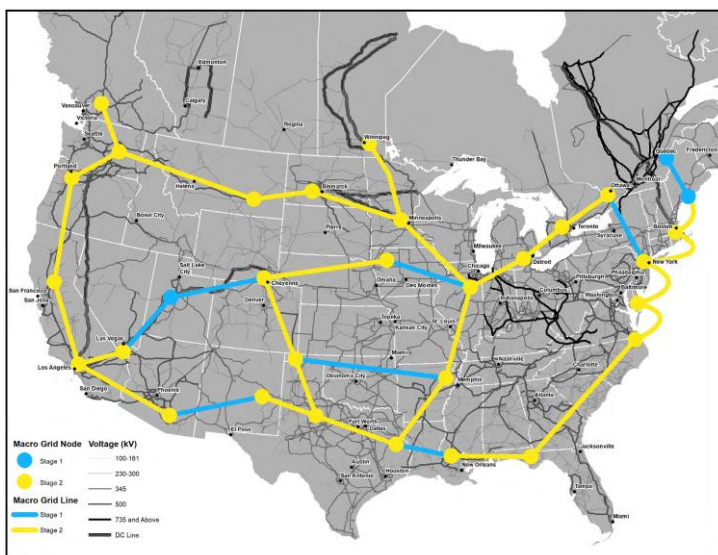

Figure 28. Conceptual macro-grid to unite the US power systems (Source ESIG, 2021a).

## 3.2 National transmission planning studies

Both high- and medium-voltage-level investments will require strong proactive steps and public engagement in long-term planning, assessing costs and working with citizens on social acceptance. In Ireland and Germany, a stepwise process has been developed to increase transparency. Investments in the network can be partly integrated in renewals of ageing network assets. In France, Germany, the Netherlands, and Denmark, the system operators are also responsible for connecting offshore WPPs.

In France, a 15-year timescale (2021–2035) is covered in RTE TNDP (2019) with several scenarios for geographic distribution of renewable energy sources, consumption, changes in the nuclear fleet, etc. (Figure 29, Figure 30). The future installation of offshore wind power plants in the North Sea, the Channel, the Atlantic Ocean, and the Mediterranean Sea, for a total of 10 GW–15 GW of offshore wind power during the next 15 years, is also investigated. A high share of variable renewables will have different effects on four distinct parts of the network:

- Regional high-voltage networks will be strongly affected by further development of variable renewables. These 63-kV, 90-kV, and 225-kV networks, operated by RTE in France, were historically built to supply most demand and have been adapted in recent years to interconnect small and medium solar PV and land-based wind generation. The main grid investments before 2030 are seen in this network.
- Very high-voltage networks (400-kV backbone) connect large-scale generators, interconnectors, and major load centers and help to balance variable renewable generation distributed across the national territory. The capacity of these power lines is optimized for the present location of generators, load centers, and interconnectors. The best potential locations for renewable generation, however, are seldom close to load centers, even if generation is distributed. The development of renewable generation (and the decommissioning of conventional generation) can therefore be expected to increase transmission flows across the whole system and require the expansion of the 400-kV infrastructure. Some weak corridors have been identified in 400-kV networks in France, but most investment needs are seen after 2030.
- Interconnectors allow for the optimization of the European mix of generation, demand, and flexibility while improving the security of the supply. They also help to balance variable renewable generation at the European scale. The need for interconnectors depends on the evolution of the different national generation, demand, and flexibility mixes in Europe.
- Offshore networks are not only necessary to connect offshore facilities, which can play a key role in a generation mix with high variable renewables, but also to create interconnections, even between mainland countries if the social acceptability of land-based, large overhead power lines is low.

Beyond 2030, as the development of renewables continues, transmission investment needs would be even more structural and higher than estimated for the previous decade, possibly on the scale experienced when the nuclear fleet was developed from the 1970s to the 1990s (Figure 31). The investment needs in this period are expected to increase regardless of the kind of the network considered—regional, very high voltage, interconnectors, or offshore. Between 2035 and 2050, very high-voltage and offshore networks, as well as possibly interconnectors, should account for a larger share of investment than between 2020 and 2035.

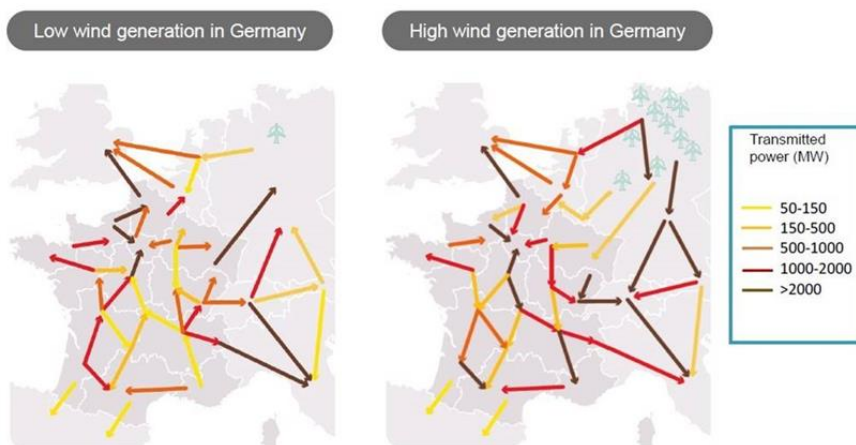

Figure 29. Influence of wind generation in Germany on the transmission grid in France (Source: IEA-RTE, 2021).

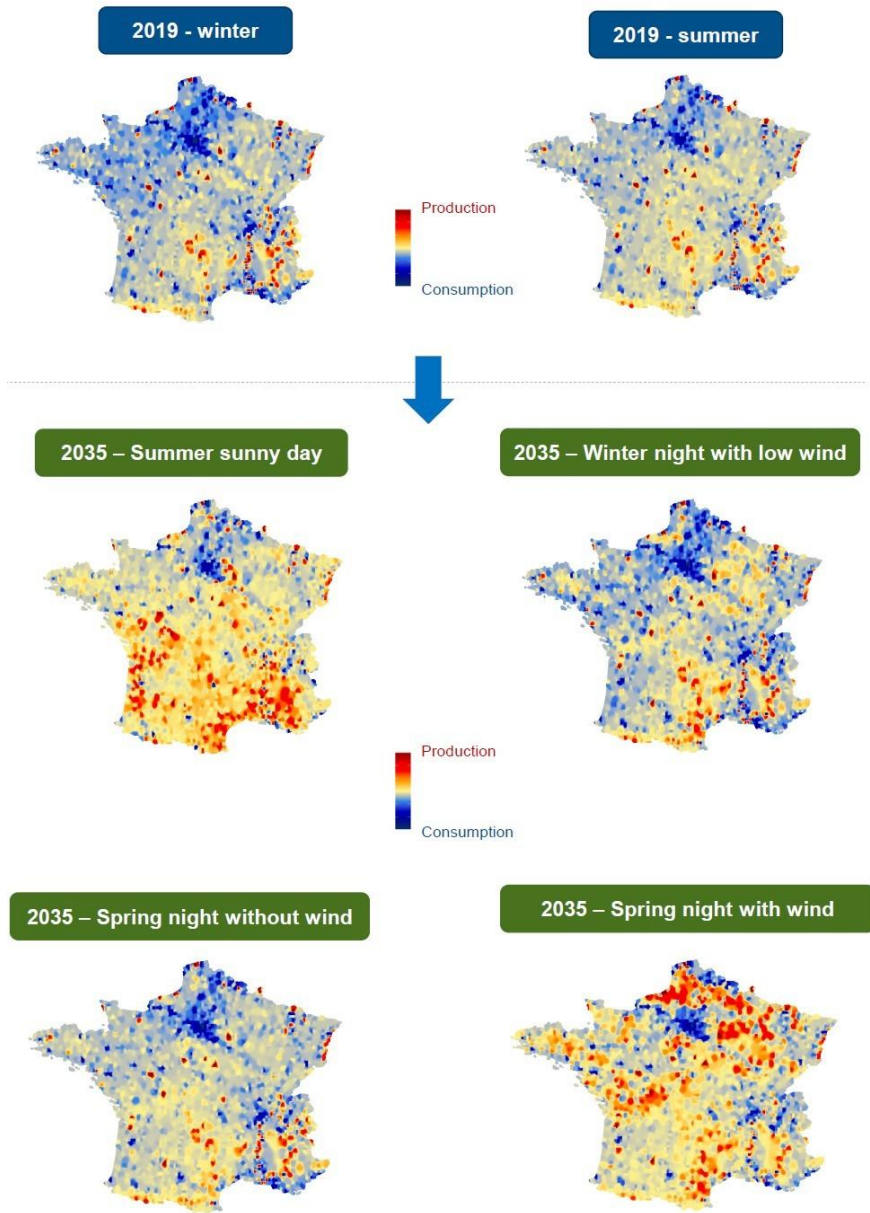

Figure 30. Typical distributions of electricity production and load, 2019 and 2035. Note: 2035 scenario based on France's Multiannual Energy Plan. (Source: IEA-RTE, 2021).

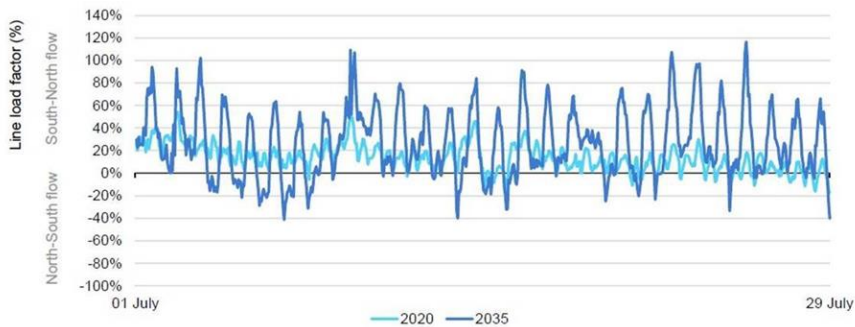

Figure 31. Expected evolution of flows on a north-south axis of France's transmission grid, today and for 2035 (Source: IEA-RTE, 2021).

The island of Ireland will have a decade of significant change in terms of demand growth (including large data centers), retirements of significant volumes of thermal generation, and the growth of renewable generation (EirGrid & SONI, 2019):

- Renewable generation capacity across the island is expected to increase from approximate 6 GW in 2020 to between 9 GW–12 GW, depending on the future scenario considered. Mostly, this will be in the form of new land-based wind generation, supported by repowering projects, connected at the transmission and distribution voltage levels, but also in the form of offshore wind generation located in the Irish Sea, along with grid-scale and small-scale solar generation (most noticeably in Northern Ireland, at present).
- Much of the land-based wind generation will be connected to the west, leading to a need for network reinforcement in the northwest, west, and south-west.
- Short-circuit level and other studies show that there are particularly good opportunities for new generation in the east of Northern Ireland and north Dublin (aligning with large energy user locations).
- Providing expanded import/export opportunities for variable renewable energy (VRE), and participation in external electricity markets, further HVDC interconnection (500 MW) with Great Britain is planned, along with a 700-MW HVDC project to France.
- A second north-south AC (400-kV) transmission overhead interconnection between Ireland and Northern Ireland is planned for the next 5 years, which is seen as an essential element of improving the security of the supply and generation adequacy across the island. This particular project has faced many planning delays and court proceedings, with a wide range of options having been proposed and studied, including underground cabling.



In Germany, there is broad consensus regarding the need for grid expansion. New route construction and the precise location will be done following a five-step-process with significant public involvement ([www.netzausbau.de](http://www.netzausbau.de)):

- The regulator Bundesnetzagentur will approve the scenario framework and resulting network development plan and environmental assessment, which has rounds of stakeholder participation.
- The state governments start the legislative process for the network projects inside their federal state.
- If the planned extrahigh-voltage cable crosses national or federal borders, the Bundesnetzagentur decides on the corridors proposed by the TSOs, in Federal Sectoral Planning, which includes a strategic environmental assessment. The TSOs must consider several alternative routes for each corridor. Their proposals are discussed publicly and assessed for their environmental compatibility. At the end, a planning approval decision is reached with the routes that have the least impact on people and the environment.

Within the grid extension plan for years 2019–2030, executed by the German TSOs, approximately 10150 km must be developed until 2030, of which 3300 km are DC new construction, 500 km are AC new construction, 300 km are DC interconnections, 5750 km are AC grid reinforcement, and 300 km are AC/DC conversion. Currently, 7850 km of the 10150 km has already been approved and serves as the draft for the federal requirement plan (Bundesnetzagentur, 2019)

### 3.3 Offshore grid infrastructure

The offshore strategy of the European Union (EC, 2020) foresees a total of 300 GW of offshore wind to be connected by 2050 (without Great Britain installations), of which the highest share is expected in the northern seas. Offshore wind deployment has started with the classic radial offshore connection and point-to-point interconnections, but there is also potential to combine a number of individual offshore WPPs to form meshed structures in offshore hybrid projects. This would allow for an increase in the interconnections between countries.

The European research project PROgress on Meshed HVDC Offshore Transmission Networks (PROMOTiON, 2016–2020) presented a small number of large offshore hubs as the most likely topology. Recommendations related to economic and regulatory frameworks include creating individual price zones for offshore wind hubs (PROMOTiON, 2020).

Similar studies also exist for the Baltic Sea (EC/COWI, 2019).

Offshore electrical networks carry a sizeable share of the cost for offshore wind, especially when they include a grid connection. In the quest to reduce the levelized cost of energy (LCOE) of offshore wind, optimization of the electrical network design is an emerging field in research and development, facilitating the further development of offshore wind power and its economic connection and integration into the land-based grids (Pérez-Rúa et al., 2020). The data basis for transmission



expansion optimization with a focus on technologies for the connection of offshore wind was reviewed and HVDC cost input data has been processed to form an improved input cost data set (Vrana & Härtel, 2018). Technical HVDC transmission link constraints have been addressed (Vrana, 2016). Also, the long-distance capabilities of subsea-cable AC transmission have been investigated in this context (Vrana & Mo 2016; Gustavsen & Mo 2017).

HVDC technology is being further developed to make offshore grids more cost-effective, reliable, and capable of providing the land-based grid support. The EU project PROMOTioN (2016–2020) demonstrated two essential technologies for gaining operational experience with the required protection and fault-clearance technologies associated with HVDC grids: HVDC grid protection systems and HVDC circuit breakers (PROMOTioN, 2020). The EU project BestPaths (2014–2018) tackled issues of interoperability for electric components such as voltage source converter (VSC) HVDC converters and recommended drafts for TSOs to be discussed with suppliers within standardization bodies (BEST PATHS D9.3, 2018).

### 3.3.1 Grid planning studies with offshore grids

**The European Network of Transmission System Operators for Electricity (ENTSO-E) Ten-Year Network Development Plan (TYNDP):** Different designs using both AC and DC technologies are currently used in planning studies:

- Point-to-point interconnections
- Radial offshore wind connections (single or via hubs)
- Hybrid projects (combination of offshore wind connections and interconnections)
- Multiterminal offshore platforms combining interconnections.

A modular and stepwise offshore grid development is assumed, with choices being made on a case-by-case basis by evaluating the technical and economic parameters. A compact hybrid offshore design could be envisaged in some cases where scheduling and technology required for interconnection and wind connection (DC or AC/voltage level) match. A decision on which option to go for is taken at the political level.

The follow-up European planning TYNDP18 and TYNDP20 summarized the individual projects being scheduled before 2030 crossing the northern seas and analyzed them as if they were one big project. These analyses showed that the benefits exceed the costs. However, as the methods applied do not focus on optimised generation connection, offshore hybrid projects have not been identified in the identification of needs exercise (ENTSO-E TYNDP, 2020). This is expected to evolve for ENTSO-S's upcoming TYNDPs.

**The North Seas Countries' Offshore Grid initiative (NSCOGI):** The collaboration of related member states, the European Commission and TSOs, analyzed the integration of offshore generation and related implications on the infrastructure (NSCOGI, 2012). The main conclusions for the offshore grid were that the amount of offshore WPPs should be very high to get the benefits of a meshed offshore grid.

The country-level targets were further decreased in later years, but the EU targets released in 2020 again show high offshore infrastructure development, and previous results from the NSCOGI studies are still valid even if the location of some of the elements, and the year of realization, might have changed.

**The North Seas Energy Cooperation (NSEC):** This follow-up organization of the NSCOGI identified potential hybrid project clusters based on the neighbourhood of planned offshore wind power plants and infrastructure (Kern et al., 2019). Twenty potential clusters have been investigated further, resulting in a list of five to six projects that could be realized before 2030. For this, cooperation among all stakeholders of all countries involved is essential. The NSEC target is to pave the way for such projects that would help realize the European climate goals.

**The North Sea Offshore Network (NSON-DK):** This research project in Denmark ([www.nson-dk-project.dk](http://www.nson-dk-project.dk), 2016–2020) studied how the future offshore grid development will affect the Danish power system. The meshed grid scenario—integrating offshore WPPs and transmission infrastructure in the North Sea—shows lower system costs compared to a scenario with only radial connections between countries and from offshore WPPs to land-based WPPs (Gea-Bermúdez et al., 2020). The meshed grid scenario slightly favors offshore wind compared to land-based wind and solar PV, but a combination of wind and solar PV is found to be beneficial on a European scale in all scenarios (Koivisto et al., 2020b). Average electricity prices in 2050 are expected to be lower and more volatile, but no significant difference between the price volatility in the radial and meshed grid scenario was found. In the meshed grid scenario, the feasibility of energy island solutions was shown.

Sector coupling is expected to further increase the importance of offshore wind in the green transition (Koivisto et al., 2020c). The main conclusions and recommendations for system balancing as well as adequacy, policy, and regulatory aspects are presented in NSON-DK (2020). Real-time imbalance in the Nordic network is lower in the meshed grid scenario than the radial scenario. Adequacy results for Denmark are very similar in the radial and meshed scenarios. Quantitative analyses confirm that integrated offshore solutions connecting different North Sea countries will create total net societal benefits. The benefits and costs, however, are not equally shared among the countries, and cost-benefit sharing mechanisms will be needed to achieve a fair allocation and therewith adequate incentives for the realization of interconnected offshore hubs in all countries. Creating a separate offshore bidding zone can lead to a more efficient energy system.

**The North Sea Offshore Network (NSON-NO):** This research project in Norway published a review and gap analysis of the technologies, including storage offshore (Vrana & Torres Olguin 2015). The power electronic technologies for DC grids have been reviewed in detail (Adam et al. 2019). As a follow-up to the 2015 report, the optimization and simulation approaches for multinational transmission expansion planning using the North Sea area as a case study found that (1) a high level of granularity in input data is needed to capture variations in operational conditions in transmission expansion planning models, (2) scenarios should be exploited to account for long-term uncertainty and its information value in terms of hedging and

timing, and (3) important additional gains can be achieved in the offshore grid planning process by combining traditional transmission expansion planning optimization tools with methods from cooperative game theory and systems engineering. A framework for multinational cost-benefit allocation schemes has been proposed to incentivize cooperation within grid planning considering market integration and the utilization of renewable energy research and flexibility assets (Kristiansen, 2019).

### 3.3.2 Energy islands

**The North Sea Wind Power Hub (NSWPH)** is a joint initiative started by system operators TenneT TSO B.V. (Netherlands), Energinet (Denmark), and TenneT TSO GmbH (Germany). Cost-saving potential related to offshore platforms is assumed to be gained by building artificial islands, potentially merging cross-sectorial assets as well. Large amounts of offshore wind located nearby could be connected to these islands via AC technology, and from the island, multiple HVDC connections will connect to surrounding North Sea countries. The advantages of this conceptual idea include:

- Allowing for synergies in infrastructure by combining wind power plant connections and regional interconnectors
- Enabling the construction of traditionally costly offshore equipment in a land-based environment—for example, offshore HVDC platforms
- The allocation of offshore wind power plant logistics, assembly centers, and crew on the island.

The concept is demonstrated in Figure 32.



Figure 32. North Sea Wind Power Hub concept with Energy Island concept (left) and the option of increased regional interconnection (right).

The concept would involve up to three islands, each covering an area of 6 km<sup>2</sup>, and facilitating approximately 30 GW of offshore wind generation, connected via AC connections. The islands themselves would be interconnected via 15 HVDC links, each 2 GW in size. Overall, between 70 GW and 100 GW of offshore wind

generation, covering an area of between 11,000 km<sup>2</sup> and 20,000 km<sup>2</sup>, could be connected to these islands. Hard substrates would cover an area of approximately 4.4 km<sup>2</sup>. The implementation of a project of this scale would require considerable studies into the environmental impact of such infrastructure. This concept is estimated to provide a 7% LCOE reduction for offshore wind when compared to present near-shore, AC-connected offshore wind. Engineering challenges, suitable market arrangements, necessary regulatory frameworks, necessary flexibility, and the potential reduction in costs associated with the concept are still being analyzed.

The Danish government intends to establish two energy islands by 2030: one in the North Sea, connecting 3 GW of offshore wind; and another one in the Baltic Sea, connecting 2 GW of offshore wind, which is equivalent to 75% of today's peak load. These islands might integrate sectors as well, e.g., applying power to gas (P2G) solutions. The island in the North Sea will be an artificial island, which later could be extended to connect 10 GW of offshore wind and will be connected to neighbouring countries.

### 3.4 Overplanting wind capacity to transmission line

Capacity optimization can lead to a so-called overplanting, where a larger wind power capacity will be installed at the site than stipulated in the connection agreement with TSOs. A technically straightforward concept (Figure 33), overplanting's value is mainly determined by the regulatory regime. Offshore WPPs in the United Kingdom show benefits in overplanting (Wolter et al., 2016).

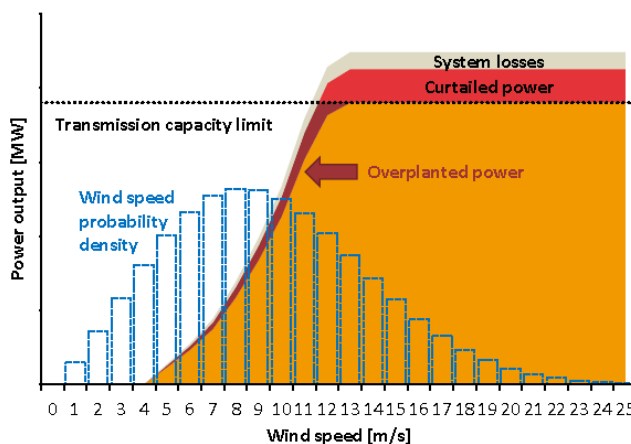

Figure 33. Illustration of the concept of overplanting (Source: Wolter et al., 2016).

The overplanting concept, also referred to as overcapacity, has been applied to WPPs in Portugal since 2007, allowing for the installation of wind capacity of a maximum of 120% of the original grid connection permit. In 2019, this overplanting approach was extended to the possibility of adding more than one primary energy

source—for example, adding solar PV instead of wind—and also installing energy storage within so-called hybrid power plants. This will enable the benefits of local complementary resources and potentially increase the load factor of the electric infrastructure (DL-76/2019, Diário da República. Presidência do Conselho de Ministros, Lisboa, pp. 2792–2865, 2019).

## **4. Ensuring long-term reliability and security of supply**

Wind power will provide more capacity and thus increase the reliability of the power system; however, the benefits of added capacity vary depending on how much wind resource is available during times of peak loads. In most countries, this is not a critical question in the start of deployment; however, there is already experience from conventional power plants withdrawing from the market due to reduced operating times to such an extent that their economics deteriorate. This will raise the question of resource (or generation) adequacy in the power system.

To assess resource (generation) adequacy, capacity value of wind power needs to be assessed. The capacity value has a decreasing trend unless new areas are added where the generation of wind does not correlate with the existing wind. So far, wind has not been considered in many countries when assessing capacity payments or strategic/planning reserves, although wind power should have an impact on the size of the strategic reserve with its capacity value. It is recommended that the adequacy analysis should adapt to reflect wind power capacity value in both studied and neighbouring areas (considering feasible import possibilities). Wind power could be paid in relation to its contribution to adequacy in the same way as other power plants (Söder et al., 2020).

Addressing concerns of generation capacity (resource) adequacy in future systems where wind and solar energy become dominant, new metrics and methods are needed to account for flexibility in demand and storage that are not captured in current tools. Considering power system-wide resource adequacy with multi-area methods is also important. Analyses need data from more weather years to capture extreme weather events, which will increase in the future.

Revenue sufficiency from future energy-only markets is a related concern; this is discussed in Section 6.

### **4.1 Estimating capacity value of wind power**

Wind power capacity value is based on the estimation of power system adequacy, i.e., the risk of capacity deficit, for different situations. The recommended practice for capacity value calculation is effective load-carrying capacity, based on loss-of-load probability (LOLP) (Holttinen et al., 2012). The analyses are based on statistical metrics and risk analysis. Due to variability and uncertainties related to wind, solar, and demand, it is important to cover the spatial and temporal correlations between weather-dependent data.

The summary of capacity value for wind power from different studies is presented in Holttinen et al. (2016). The first few percentages of wind energy in the system have a capacity value close to its capacity factor (average generation). If the capacity factor is higher or lower than average during times of peak load, this will be reflected in the capacity value. This has been seen especially in U.S. studies comparing the capacity value of offshore and land-based wind. Offshore wind's significantly

larger capacity value is due to a higher capacity factor and stronger correlation with system needs.

An extensive quantification of both land-based and offshore wind capacity value in the western United States was made in 2020, adding marginal amounts of wind to the wind shares of 8.4% land-based and 0% offshore (Jorgenson et al., 2021). The analysis, which leveraged NREL's probabilistic resource adequacy tool called the Probabilistic Resource Adequacy Suite (PRAS), used 7 years of system load, wind, and solar profiles to calculate the wind capacity value across years and locations. Average wind capacity value was 16% for land-based turbines and 41% for offshore turbines, with large regional variations. The average wind capacity value increases to 20% for land-based and 53% for offshore when considering only the sites in the top 25th percentile of capacity factor.

Adding wind power to the system will result in decreasing capacity value. The smaller the power system area is, the faster the capacity value will decline with higher shares of wind energy (Holtinen et al., 2016).

#### **4.1.1 Multiple-year data sets needed for capacity value estimates**

Multiple-year data sets significantly increase the robustness of capacity value results compared to assessments from 1–5 years. This is due to interannual variability in the wind resource. In Ireland, 8 years was considered sufficient to reach robust results for a capacity value of wind (Hasche et al., 2011). In some systems, more than 10 years of data are needed to get robust results on the capacity value of wind power (see example from Finland in Figure 34). In France, Electricité de France considers a year with hourly resolution of time-synchronized demand, hydro, wind, and PV for 55 weather years (real data) combined with scenarios of generation availability (from outage simulations). This produces 165 year long simulations representing different climatic conditions and plant outages (EU-SysFlex D2.5, 2020).

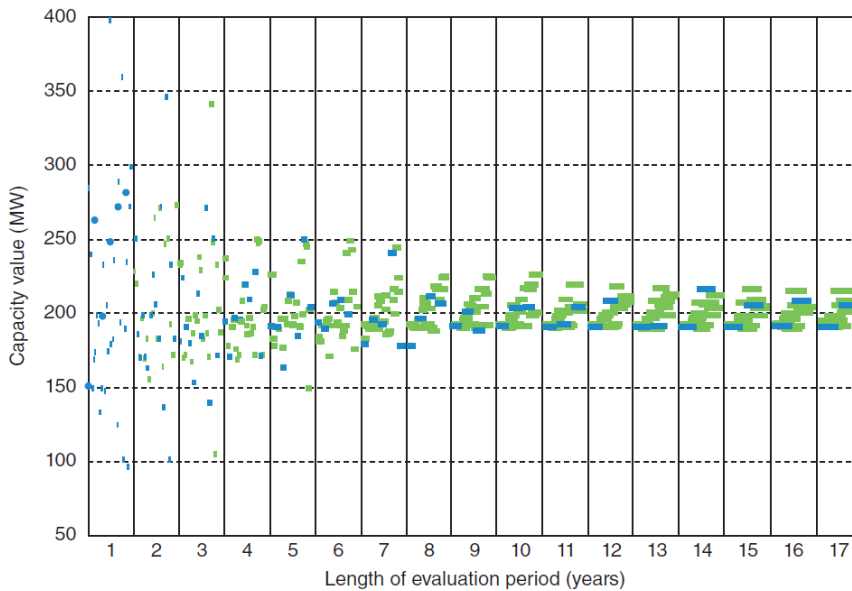

Figure 34. Capacity value of wind power in Finland using different number of years for evaluation. The data are based on 35 years of NASA (National Aeronautics and Space Administration) MERRA data. Blue markers signify independent time series, and green markers have partial overlap with some of the other time series (Source: Milligan et al., 2017).

## 4.2 Assessing resource adequacy in power systems with wind power

To assess resource adequacy, as well as the planning reserve margin needed for security of supply, having a larger area makes a difference. For example, the planning reserve margin requirement estimated for SPP in the United States was greater than 17% before 1998 (EWITS, 2010), reduced to 13.6% in 2016, and further reduced to 12% in 2017 (Nickell, 2017) due to calculations including interconnection with an aggregated, larger area. The benefits will be further increased with larger shares of wind and solar.

Capturing extreme events is also important, and here the use of spatially, temporal, and inter-modal (i.e., between demand, wind, and solar) hazard correlations is crucial, as is covering longer time series of data for robust results. In France, the system operator RTE uses 200 weather scenarios (wind at 100 m, temperature at 2 m, global irradiance, and cloud cover) for Europe with a 50-km resolution to determine wind and PV production per area/country.

For future wind- and solar-dominated power systems, current resource adequacy tools would end in recommending a build-out of peaker plants for security of supply.



New methods and metrics are needed, starting with including flexibility from storage and demand to the tools.

#### **4.2.1 Capturing extreme events**

In the United States, the impact of extreme weather events—such as hurricanes, winter storms, and heat and cold waves—on increasing shares of wind and solar resource availability was assessed based on years 2007–2013. A subset of the events was also studied using production cost modelling to evaluate system operations during stressful meteorological events. Robust conclusions would require the investigation of a wider set of events, but some observations from the limited data set show that mild weather events can produce extended periods of low wind and solar resource, and they should be a focus of planners. During cold waves energy adequacy risk is greatest in the days that follow the initial cold front due to the uncertainty of the spatial and temporal extent of the wind speed lull. During heat waves, solar PV capacity will drive operational changes, but total energy contribution from wind, especially after sunset, will also impact the level of system stress. Tropical storm impacts on renewable resource availability are often localized and of less impact than direct damage to generation, transmission, and distribution infrastructure. Understanding the characteristics and diversity of wind and solar resources—at small and large geographic scales—is key to ensuring that they contribute to resource adequacy (Novacheck et al., 2021).

In the United Kingdom, Dawkins (2019) summarized the key findings from the studies relevant for understanding U.K. weather and climate-related sensitivities and risks associated with a highly renewable energy system. The findings, similar to those reported in the United States, suggest that extreme stress on the energy system results from extreme magnitudes and fluctuations in energy demand, shown to vary with temperature, and renewable electricity supply, shown to vary with wind speed. Wind-related adverse weather conditions include wintertime peak residual demand (demand net of renewable supply), wintertime wind power ramping (large fluctuations in power generation in a short time window), and summertime wind drought. To cope with the extreme events, adequate backup capacity will be needed, including energy storage and firm (non-weather-related) power generation capacity plus demand flexibility. This involves all types of energy storage—from thermal, electrical, to gas, including hydrogen storage, and including several alternatives for long-duration energy storage.

#### **4.2.2 Multi-area methods**

When assessing the adequacy of a studied area, the possibility to import from neighbouring areas is often not considered, even if that is usually available in real scarcity events, before considering any involuntary load disruption. With larger volumes of wind power, more transmission between areas will become increasingly beneficial.

To consider the value of this import in the adequacy calculations is still an area of research with evolving methodologies.

**In Sweden**, a method for power system reliability in multi-area systems has been developed and applied to the Nordic power system considering correlated wind power in the different areas. LOLP per area is estimated considering possible import and with the limitations of import from nearby regions to the studied area. This means an estimation of multi-area power system adequacy (Tomasson & Söder, 2017; Tomasson & Söder, 2018). It also means that wind power in one area gets a slightly higher capacity value when the possibility to increase the adequacy in neighbouring areas is also considered (Crosara et al., 2019). Simulations for three future scenarios (2020, 2025, and 2030) point out that the weakest areas (Finland and southern Sweden) are also the ones that will face nuclear decommissioning in the years to come, and they highlight that the investments in interconnections and wind power considered in the scenarios are not sufficient to maintain the current reliability levels. If today's reliability levels are considered necessary, then possible solutions include more flexible demand, higher production capacity, and/or more interconnections (Terrier, 2017).

**ENTSO-E** releases a Mid-term Adequacy Forecast (MAF) report every year (<https://www.entsoe.eu/outlooks/midterm/>). This is a pan-European assessment of power system adequacy spanning the next 10 years. It is based on a probabilistic analysis that aims to model and analyze possible events with potentially adverse consequences for the supply of electric power. The results illustrate the minimum and maximum loss-of-load expectation (LOLE) per region obtained using a state-of-the-art Monte Carlo simulation methodology. The availability of generation and transmission resources are probabilistically assessed. Random outages represent different availability of capacity resources and transmission lines, which are subject to failures that cannot be predicted beforehand and might have a significant impact on resource adequacy. Monte Carlo sample years combine the climate-dependent variables and random outages as follows: (1) Climate years are first selected one by one; (2) Each climate year is associated with random outage samples, i.e., randomly assigned unplanned outage patterns for thermal units as well as for interconnectors; (3) The combination of the climate years and the random unplanned outage patterns defines the Monte Carlo sample years analyzed. The number of Monte Carlo sample years ensures convergence of the results. Explicit and implicit demand response is considered in the assessment, with data on potential for demand reduction, postponement, or shifting based on the best forecast in the modelled zone (EU, 2019). For the 2020 edition, all demand profiles for target years 2025 and 2030 were derived by combining historical data from 2012 to 2016 and forecasted based on the climate years from 1982 to 2016 (MAF, 2020).

ENTSO-E also uses resource adequacy tools for shorter, week-ahead assessments. If there is lack of energy—at any given time—in a country, potential help from other countries depends on the overall availability of electrical energy and the grid capacity to transmit it to the country in need of energy. Coreso, the centralized regional security coordinator, provides coordination services to Western Europe TSOs, carrying out a short-term adequacy assessment service. A regional

diagnosis of short-/medium-term active power adequacy is made in line with agreed ENTSO-E methodologies. This adequacy review shall be made comparing local adequacy inputs, forecast scenarios for VRE and load, and grid capacity to carry cross-border exchanges. This diagnosis can include recommendations such as remedial actions to optimize cross-border exchanges and requests to balancing service providers in the coordinated balancing area to change their availability status.

#### **4.2.3 New metrics and methods**

Traditional resource adequacy methods and metrics based on conventional generation and fixed load are no longer adequate for the changing generation mix, consisting of wind, solar, battery storage, and flexible demand. With more demand-side participation and increasingly flexible resources, the adequacy metrics need to be updated to properly reflect the needs of society. For example, the most common metrics (e.g., loss of load probability LOLP) are arbitrarily employed with respect to the societal requirements. Data and methods are evolving to account for greater operational representation, and there is a growing consensus that the resulting metrics should capture the size, duration, frequency, and timing of potential loss of load events. Metrics like expected unserved energy (EUE) might be more meaningful if the energy, as opposed to capacity, limitations become more dominant (ESIG, 2019).

Metrics for LOLP and EUE make sense if there is a fraction of the demand that is totally inflexible—that is, that “must” be served. If there is enough flexible or responsive demand, the classic adequacy problem recedes and is replaced by a cost-minimization problem, where the investment cost is balanced against the expected cost of compensating consumers for reducing or shifting their demand. The traditional methods aim to quantify the amount of peaking generation (such as gas turbines) that needs to be added to keep the system adequate. With high shares of wind and solar, this will result in a costly system compared to enhancing demand flexibility and storage and considering neighbouring area imports (ESIG, 2019).

Adapting and enhancing the adequacy calculation methodologies will be needed because traditionally they do a poor job of representing the impact of important enablers of moving toward 100% renewables: transmission, generation embedded in the distribution system, storage, demand participation, and sector coupling. A set of new guiding principles have been developed for modern power systems by the ESIG project Redefining Resource Adequacy (ESIG, 2021b):

- Principle 1: Quantifying size, frequency, duration, and timing of capacity shortfalls is critical to finding the right resource solutions.
- Principle 2: Chronological operations must be modeled across many weather years.
- Principle 3: There is no such thing as perfect capacity.
- Principle 4: Load participation fundamentally changes the resource adequacy construct.
- Principle 5: Neighboring grids and transmission should be modeled as capacity resources.

- Principle 6: Reliability criteria should be transparent and economic

In addition, the Task 25 collaboration paper on the first recommendations toward a future with 100% renewables (Holttinen et al., 2020) lists:

- Consider reliability levels: A common loss of load target (loss-of-load expectation LOLE, quantifying the expected number of days when capacity is insufficient to meet load) is one event in 10 years, but a lower reliability target, such as two events per year, could be appropriate. Rolling brownouts could be allowed when load (price) responsiveness is insufficient.
- Consider the impact of interannual resource variability in the yearly energy reliability.
- Improve data and the sensitivity to capture extreme events. Current models capture correlated events if represented in the data, which means data should be from 10+ years.
- Include neighboring areas, with some recent model developments using Monte Carlo techniques.

## 5. Ensuring short-term system reliability

The impacts of wind and solar energy on short-term reliability involve the potential impacts on the short-term balancing of supply and demand: setting the amount of operational reserves for frequency control. With larger shares of solar and wind power, the impact on power system dynamics is increasingly important to assess. And in addition to assessing the impacts of variability and uncertainty, asynchronous connection by the inverters will need to be considered.

Wind power has possibilities to support the grid. Together with other new flexibility options, this should be considered when studying larger shares of variable generation in future power and energy systems (see sections 6.2 and 6.5).

An example of a large wind and solar integration study is the Eastern Renewable Generation Integration Study (ERGIS) in the United States. The operational impacts of up to 30% VRE shares on an annual basis in the Eastern Interconnection were examined in several scenarios of transmission build-outs (Bloom et al., 2016). The Eastern Interconnection was modelled with a unit commitment and economic dispatch model with more than 5,600 generating units and 60,000 transmission nodes at a 5-minute temporal resolution to understand the subhourly impacts of the large-scale adoption of wind and PV power. Significant changes in system operations were observed in the operation of thermal and hydro generation, in the power flows on transmission lines, in the operations at sunrise and sunset, and in the balancing area operational practices; however, the system was found to be able to be operated reliably in all studied scenarios.

The results of seven integration studies with a wind power share of 30%–40% of yearly energy show that additional storage for system-level demand-generation balancing was not necessary; the possibility to balance wind and solar in a larger area decreased the balancing challenges, and more transmission reduced the curtailment challenges (Söder et al., 2017). More integration study results are summarized in previous Task 25 reports (Holttinen et al., 2009; Holttinen et al., 2012; Holttinen et al., 2016 and Holttinen et al., 2019).

### 5.1 Operating reserves

The impact of wind power on operating reserves for balancing and frequency control has been the focus of many integration studies for decades. Power systems balance the load and generation in a balancing area with operating reserves. Wind power imbalances will be merged with other imbalances in the power system. Operating reserve for balancing and frequency control is divided into several timescales of response—with a very general division, we can talk about automatically activated reserves (in a timescale of seconds) and manually activated reserves (in a timescale of 10 minutes or so). This section summarizes the experience and studies regarding the allocation and use of operating reserves in systems with high shares of wind power. Wind power can also provide operating reserves; this is described in Section 6.2.

### 5.1.1 Experience of operating reserves in regions with high shares of wind power

Solar and wind power will add uncertainty and variability to system operation. This will first be seen as an increase in the use of operating reserves and at some point also as increased amounts of allocated reserves in the system. Surprisingly, recent experiences of decreasing reserve requirements have also been reported (in Germany and Texas), mainly due to changes in operational practices that offset any increase that wind and solar pose to the use of reserves. This highlights the importance of changes in operational practices where inefficiencies might exist as a strong mitigation for increased balancing efforts due to wind and solar.

**In France**, the anticipation strategy to assess the required reserves and available margins used by the system operator RTE has been well suited to managing the system with increasing shares of VRE sources, provided the computation is frequently updated. A new tool called MAUI automatically computes the required reserve and the available margin on a rolling horizon. The available margin assessment considers the minimum advance notice resulting from the dynamic constraints of each generation unit (Figure 35).

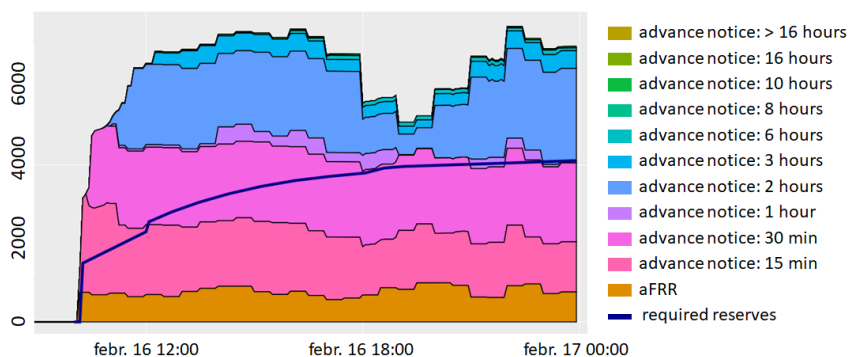

Figure 35. Automated assessment by RTE on a rolling horizon of required and available margins (Source: RTE internal report).

There is also experience in the benefits of changing operational practices from sharing balancing between system operators, exceeding the increased balancing needs from wind and solar energy. In Germany, the benefit of sharing balancing responsibility between the four system operators has been much larger than the increased impact wind and solar have had on their system (Kuwahata & Merk, 2017). The dramatic decrease in the activation of secondary frequency control reserves is shown in Figure 36. Another example of the powerful benefits of sharing balancing is the Western energy imbalance market (EIM). Since its launch in 2014, the energy imbalance market has enhanced grid reliability, generated millions of dollars in benefits for participants, and improved the integration of renewable energy resources.

Gross benefits are estimated to exceed \$1 billion and a savings of half a million metric tons of carbon dioxide (CO<sub>2</sub>) emissions ([www.westerneim.com](http://www.westerneim.com)).

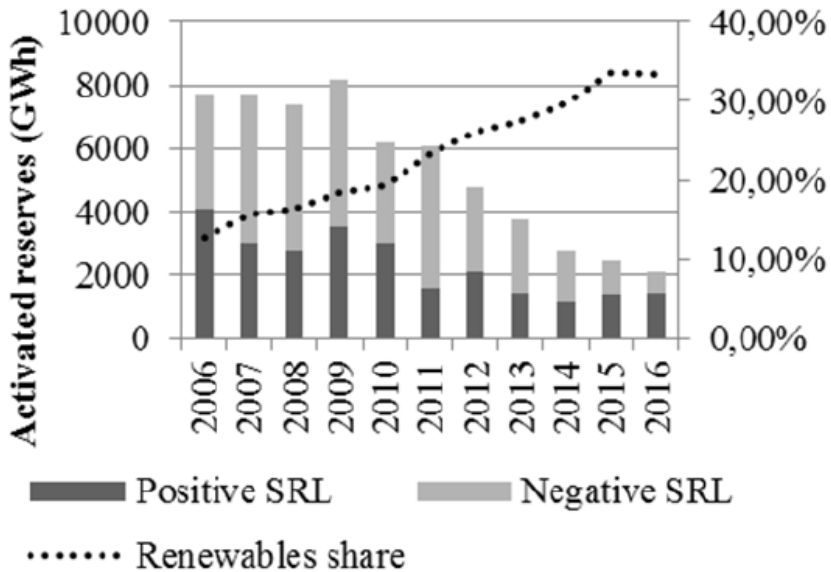

Figure 36. Decrease of secondary reserve activation (SRL) in Germany thanks to new operational and market rules—and despite the increase in the share of renewables (Source: Kuwahata & Merk, 2017).

**In Texas**, the main driver for decreased secondary reserve requirements was the transition from a 15-minute zonal to a 5-minute nodal market on December 1, 2010. The decrease is shown in Figure 37. Interestingly, there is another effect reported from the Electric Reliability Council of Texas (ERCOT) due to the effective primary frequency response available from WPPs: As wind capacity has continued to increase, regulation reserve requirements have continued to decline (Figure 38, see also example Figure 41 on how reserve products responding at different time scales are working together). Note that in mid-2017, up-regulation requirements had decreased further to 350–400 MW (wind capacity was almost 19 GW). ERCOT found a significant positive impact from introducing the requirement that all generators, including wind and solar, provide primary frequency response (PFR, governor or governor-like response). At the time the requirement was introduced, existing generators were required to be retrofitted, if possible. Wind plants always provide overfrequency response when they are operating (i.e., they curtail if frequency is high), but they only provide underfrequency response if they are curtailed for some other reason (i.e., they are not precurtailed specifically to provide the up-response but rather will provide the up-response if they are curtailed because of oversupply reasons or due to transmission congestion).

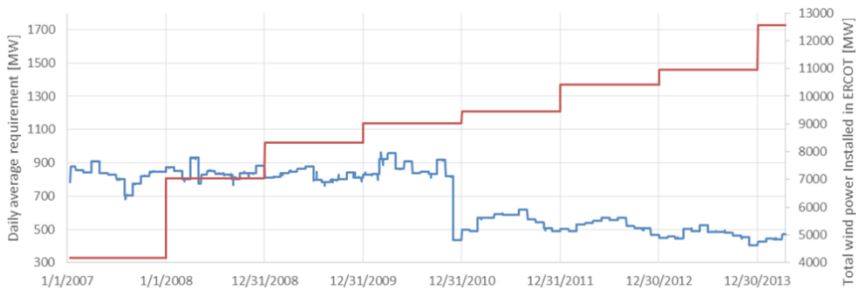

Figure 37. Up-regulation secondary reserve requirement in ERCOT (blue) and total wind power capacity in ERCOT (red) (Source: The University of Texas at Austin energy institute, 2017).

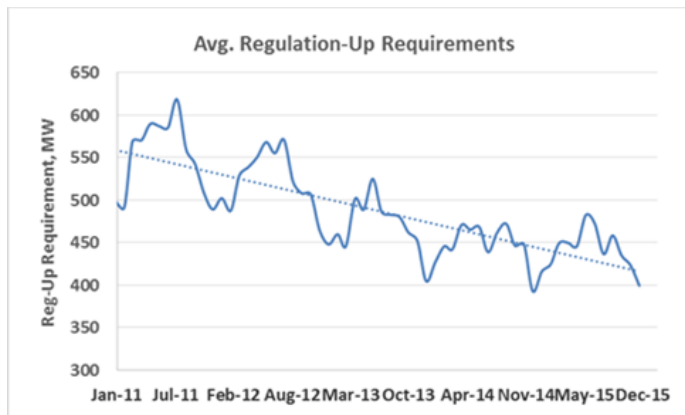

Figure 38. Average up-regulation requirements during 2011–2015 for ERCOT, Texas. The cumulative wind capacity increased from 9.4 to 15.8 GW during the same period (Source: Julia Matevosjana, ERCOT).

### 5.1.2 Estimating requirements for operating reserves

The prevailing practice in integrating variable renewables is to procure a certain amount of reserve to compensate for the uncertainties in the net load. Such reserves are mainly affected by demand, wind and solar forecasting errors, and unplanned outages of power plants or interconnectors (Figure 39).



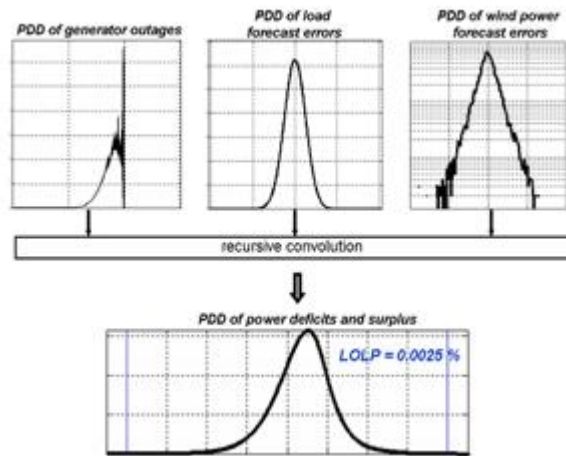

Figure 39. Example of combining the uncertainties from generation and demand and from using reliability (LOLP) as a confidence level to determine the impact of additional wind power to the amount of operating reserves needed (Source: Fraunhofer IEE).

There are a lot of estimates on the increase in operating reserve due to wind power. The main impact, for studies considering 10%–30% shares of wind, has been on the slower responding, manually activated reserves (10 ... 15 minutes), and the impact to fast-response reserves is smaller (Holttinen et al., 2016, Section 5.2). The timescale of uncertainty has the largest impact on the results—when day-ahead or 4-hour-ahead uncertainty is accounted for, the impact of wind power will be more substantial. For example, a Nordic study (Miettinen & Holttinen, 2018) shows the importance of intraday corrections to forecast errors once the share of wind increases. Another major impact in the study results is the size of the balancing area—or whether balancing areas will share balancing. The experience from Germany confirms these findings (see previous section; Figure 36).

The quality of the wind and solar forecast will influence the reliability and operation efficiency—and the amount of operating reserve allocated. To procure excessive reserve leads to inefficient operation, whereas an inadequate amount of reserve could result in a potential reliability issue; however, because the wind and PV forecast errors are time-varying, some judgment should be applied to determine an appropriate trade-off between the economics and the risk management. Dimensioning operating reserves with the help of deterministic criteria that determine the capacity for a long period (several months) works out quite well with traditional power systems; however, increasing shares of variable generation introduce higher volatility to future power systems, which leads to a more volatile need for balancing. Dynamic reserve setting (such as the example of France in the previous section) will result in more cost-efficient and reliable system operation.

**In Ireland**, a method proposed for dynamically determining the operating reserve requirement considers the non-normal nature of wind power uncertainty and variability as well as their stochastic dependence on wind power forecasts (Mousavi & Flynn, 2018). Unlike existing methods, the probability density of wind power uncertainty and variability is characterized at distinct wind power forecast levels. It is shown that the obtained results for the Ireland case are sensitive to normality and independence assumptions, which can lead to over-/underestimations of operating reserve requirements. The errors, which mostly occur during periods of high wind power forecasts, can range from  $-95\%$  (underestimation due to normality assumption) to  $+400\%$  (overestimation due to independence assumption) at a wind power share of  $37\%$ . The resulting errors have the potential to reduce system reliability and increase operational costs due to more frequent cases of load shedding and wind curtailment as well as the part-loading of conventional power plants.

**In Germany**, a method proposed for the dimensioning of reserve (Jost et al., 2015) uses quantile regression based on artificial neural networks to forecast the reserve capacities to meet the desired security level. The method was tested for the day-ahead dimensioning of frequency restoration reserve capacities in Germany and compared to static ex-post dimensioning results that (1) have the same loss of time (percentage with insufficient reserve capacity), (2) have the same average reserve capacity, and (3) exactly meet the loss-of-time target. The dynamic dimensioning shows advantages concerning all criteria for both negative and positive frequency restoration reserve. Compared to the static dimensioning for the loss-of-time target, the average scheduled reserve capacity as well as the loss of time is less.

Probabilistic tools for determining the impact of forecast errors on operation margins and reserve requirements can be used both during operation and in future analysis for long-term reserve needs. In the EU-SysFlex project, a dynamic probabilistic method has been used to estimate the automatic frequency restoration reserve (aFRR) requirement according to shares of renewables. Principles of the methodology are based on a probabilistic approach that aims to evaluate the power margin needs for a given time horizon (e.g., 15 minutes for aFRR), while considering a predefined risk level, at the scale of a country and for each hour of the year considered. The fundamental part of the tool (OPIUM) lies in the modelling of the uncertainty sources, roughly divided into two main types: (1) forecast-based error (demand, PV, and wind generation) and (2) outage-based uncertainty. Considering two high shares of variable generation ( $>50\%$ ) scenarios, an estimation of aFRR requirements in Europe is given (Figure 40). Two main conclusions can be pointed out: (1) The risk level chosen by the TSO plays a major role in the aFRR requirement, and (2) the massive development of renewable energy sources will lead to a significant increase in aFRR sizing (EU-SysFlex D2.4, 2020; Morin et al., 2019). This approach addresses the sizing of 15-minute reserves, with the choice to first address aFRR. In fact, it could also cover partly manual frequency restoration reserve (mFRR). It depends on the share (for a specific country) of 15-minute reserves between aFRR and mFRR (Morin et al., 2019; also shown in Figure 41).

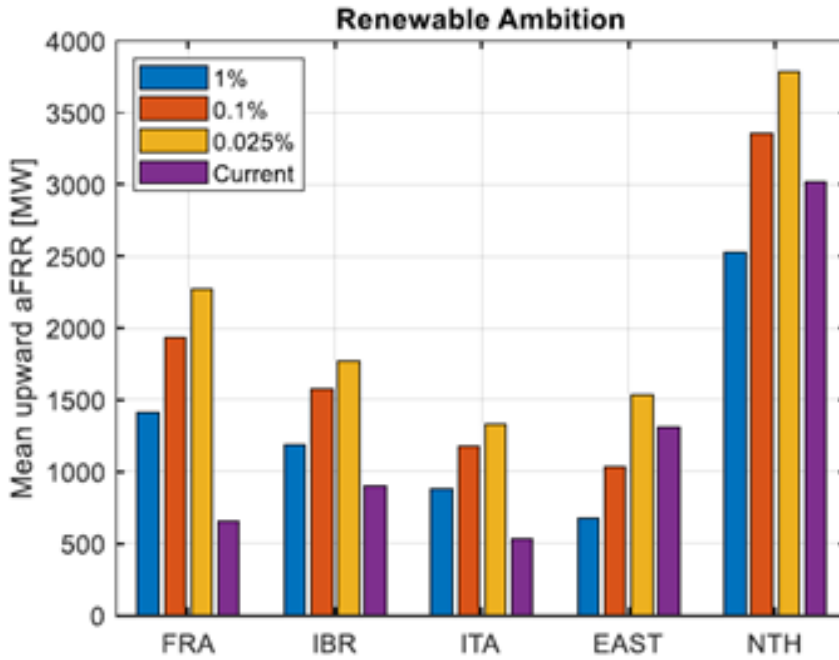

Figure 40. Evolution of mean upward margins in Europe considering several risk levels (in different colors). FRA = France; IBR = Iberia (Portugal and Spain); ITA = Italy; EAST = Poland, Czech Republic, Hungary, and Slovakia; NTH = Germany, Belgium, Luxemburg, Netherlands, Denmark, Switzerland, and Austria. The Renewable Ambition scenario has a 66% share of wind and solar in Europe (Source: EU-SysFlex project).

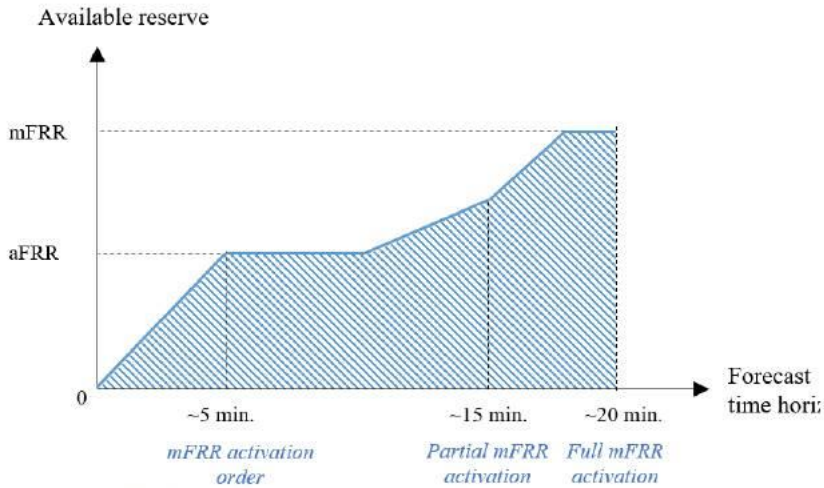

Figure 41. Example of how operating reserves are activated and divided between two reserve types: automatically and manually activated frequency restoration reserves, aFRR and mFRR (Source: Morin et al., 2019). When assessing needs for several timescale reserves, there is a danger to double count, with overlapping responses.

**In the North Sea region**, the power imbalances increase substantially toward 2050 with the addition of high offshore wind, requiring much higher volume of reserves. Although most of the imbalances can be handled through manual balancing reserves, much higher volumes of aFRR will be required to handle the real-time imbalance. For efficient utilization of resources, aFRR are recommended to be dimensioned probabilistically (NSON-DK, 2020).

**In Japan**, a loss-of-reserve capacity probability has been proposed to assess the adequacy of reserve capacity using duration curves on the magnitude and speed of a net load ramp. An example of weekly/daily duration curves of the magnitude and speed of a net load ramp (i.e., occurrence probability of each necessary flexible capacity level) is shown in Figure 42 (Tanabe et al., 2017).

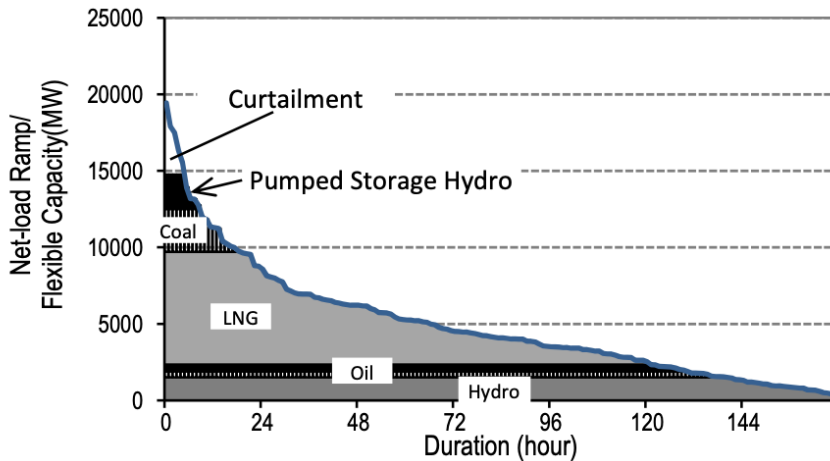

Figure 42. Duration curve of net load ramps and flexibility for managing them (Source: Tanabe et al., 2017).

## 5.2 Stability and grid security

Larger shares of wind and solar generation will change the power system characteristics because of the increased inverter-based resources (IBR) connected via power electronics interfaces; however, wind and solar power plants can also offer a promising and viable option for defence against short-term voltage and frequency instability in emerging situations. Through intelligent coordination of power electronic-based controls, system capabilities can be further enhanced.

The issues of concern for a particular system will depend on system size, wind distribution relative to the load and other generation, along with the unit commitment and network configuration (Flynn et al., 2017).

For challenges to reach 100% renewable, and IBR based generation see Section 7.

### 5.2.1 Experience on stability issues with variable generation

This section includes events where system stability has been risked, in systems with considerable amounts of wind and solar power plants. The capabilities of WPPs to improve stability are described in Section 6.2, including real experience from system operation.

Wind and solar power plants' response to fault situations has been found to be a critical issue to manage. WPP fault ride-through capability has been added to grid codes since 2005, when German and Spanish studies showed that WPP could become a maximum tripping event for the European power system (Holtinen et al., 2009). For solar power plants, the 50.2-Hz issue was discovered in Germany when several tens of gigawatts of distributed solar was added to the system at a fast pace

requiring all solar panels to be disconnected at the same overfrequency of 50.2 Hz—should this be reached, the system would experience a huge loss of power simultaneously (<https://www.modernpowersystems.com/features/featuredealing-with-the-50.2-hz-problem/>).

In Southern California, the August 16, 2016, Blue Cut Fire event resulted in a 700-MW solar PV power plant tripping and led the North American Electric Reliability Corporation (NERC) to set up the Inverter-Based Resource Performance Joint Task Force to investigate this reliability issue and propose mitigation (NERC, 2017). It has evolved to Inverter-based Resource Performance Working Group (IRPWG) looking at many different aspects related to IBRs including standards (P2800); reliability guidelines for hybrid power plants, EMT modeling, interconnection processes and studies for IBRs, etc.

In a South Australia extreme storm event, six system faults occurred in 2 minutes on September 28, 2016. Most wind turbines successfully rode through three voltage disturbances, then either reduced output or disconnected due to the activation of repetitive low-voltage ride-through protection. The existing generator performance standards did not include specific minimum requirements that would have prevented or mitigated those responses. The WPPs' fault ride-through settings were too low, not anticipating that so many subsequent faults could occur. More specific requirements for the enhanced fault ride-through capability of WPPs have been implemented since (AEMO, 2017).

In August 9<sup>th</sup>, 2019, significant storms with lightnings across the UK resulted in a series of events that ultimately caused the disconnection of approximately 1 million electricity consumers. During the event, unexpected control system response happened in the largest offshore wind power plant, due to an insufficiently damped electrical resonance in the sub-synchronous frequency range, triggered by the event. Since the event, the control system software has been updated to mitigate the observed behaviour of Hornsea One to stabilise the control system to withstand future grid disturbances in line with grid code and connection agreement requirements (NGET, 2019).

System-wide oscillations at 7 Hz and 19 Hz have been observed in the Australian grid supplying the southern and eastern region of the country. These were a result of increased penetration of IBRs in the West Murray region and reduction in the grid strength due to the displacement of synchronous generators (Modi et al., 2021). The current strategy to mitigate these oscillations and avoid any reliability event is to curtail IBRs in the West Murray regions (Badrzadeh et al., 2021). Investigations are ongoing to determine the role of different IBRs in the observed oscillations modes, i.e. to determine which IBRs contribute negatively to the system damping versus the IBRs contributing positively to the system damping (See also Section 7.3.3).

Figure 43 depicts a frequency instability event (Central Europe CE 3.12.2017) by the frequency measurements of a wide-area monitoring system in Italy. The incident occurred during very low consumption (resulting in a decrease of load contribution to damping) and a huge import in the southern part of the European power system. There were high voltage angle differences inside Italy and unavailability of some

generators, leading to non-standard power flows in the system (ENTSO-E, 2018). The incident highlighted the role of fast and correct reactions and measures to block oscillations. Although the role of VRE was not reported to be pronounced in this particular incident, development and implementation of suitable measures are required at high shares of VRE in order to ensure good damping performance and avoid severe oscillation incidents.

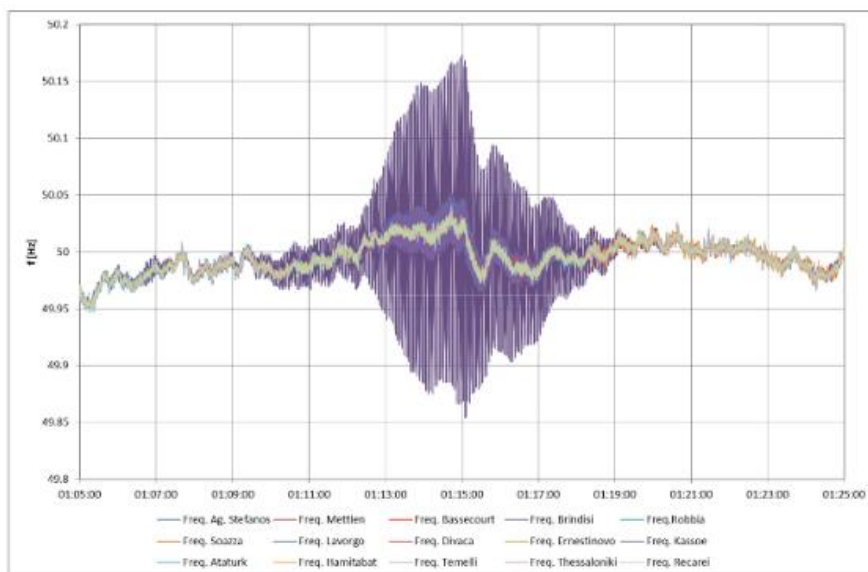

Figure 43. Frequency measured by wide-area monitoring system (WAMS) (100-ms sampling rate) on December 3, 2017 (Source: Terna).

Most stability events involving IBRs have been local in nature where a stability problem can be characterized as an unstable interaction between two systems—for example, interaction of a wind or PV power plant with the grid at its terminal because of low short-circuit strength of the grid or the presence of a series-compensated transmission line (ERCOT resonance event in the US, Adams et al., 2012; UK 2019 event NGET, 2019); an offshore wind power plant forming an unstable resonance with the offshore HVDC converter station (BorWin1, Germany, Buchhagen et al., 2015); and an HVDC converter or a STATCOM oscillating against the ac network at its terminal (China, Xie et al., 2017). Dynamic stability events involving wider network and numerous IBRs, however, are becoming more common because of ever increasing levels of IBRs and reduction in the grid stiffness due to the displacement of synchronous generators (Badrzadeh, et al., 2021; ERCOT, 2018; Shah et al., 2021b). See Sections 7.3.3 and 7.6 for studies towards 100% IBR systems.

## 5.2.2 Studies on frequency stability

The power system will experience times of lower inertia levels due to higher shares of asynchronous wind and solar generation. Both increasing asynchronous generation and decommitting synchronous generation lead to decreased inertia (Daly et al., 2019). The inertia in a power system has an influence on the dynamic behavior of the frequency after any unbalance of generation and consumption. After a sudden generator loss, in the case of low inertia (Figure 44):

1. The frequency decreases faster—that is, the rate of change of frequency (ROCOF) is higher and leads to a risk of triggering load-shedding plans.
2. The frequency minimum (nadir<sup>3</sup>) is lower, which could result in activating some generators protection relays and lead to the risk of the system frequency collapse.

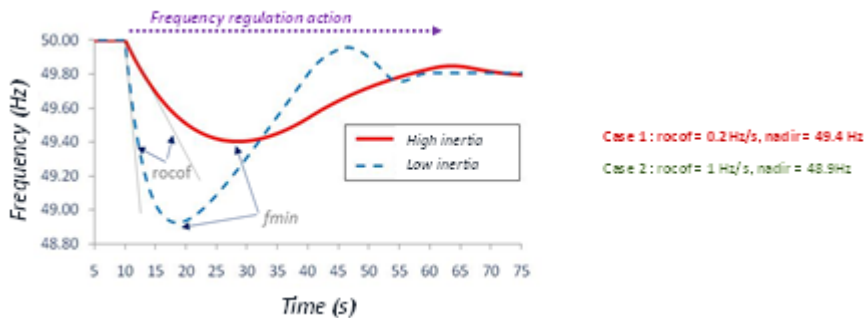

Figure 44. Illustration of nadir and ROCOF concept (Source: Prime & Wang, 2019).

Frequency stability challenges depend on system size, share of wind power, and applied control strategies. This was first studied in smaller systems, such as Ireland, but it is increasingly being studied for larger areas with higher shares of wind power.

Options to manage low inertia levels include keeping the inertia at a higher level with the must-run generators or synchronous condensers, procuring faster frequency response to arrest the frequency decline, or limiting the generation of the largest contingency in the system. The most cost-effective mix of grid-stabilizing solutions is system topology dependent and country specific. Advanced methodologies must be deployed to determine such an optimal mix. The evolution of costs for inertia solutions, according to shares of variable generation, can be depicted as in Figure 45 (Prime & Wang, 2019).

<sup>3</sup> nadir: minimum value of frequency reached during the transient period



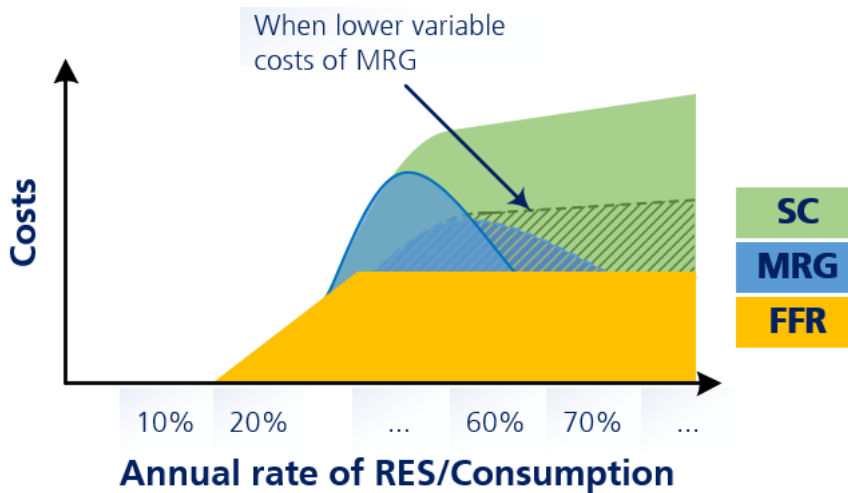

Figure 45. Mitigating low-inertia situations due to increasing shares of wind and solar. SC: synchronous condenser; MRG: must-run (synchronous) generation; FFR: fast frequency response (Source: Prime & Wang, 2019).

A detailed techno-economic comparison between synchronous condensers and STATCOM equipped with a battery energy storage system (BESS) show that both technologies can supply inertial response, but with existing BESS technology and prices, synchronous condenser inertial response appears much cheaper than that of BESS. Synchronous condensers can provide voltage regulation services and short-circuit power in a more cost-effective manner (Biellmann et al., 2020).

In the island system of Ireland, the frequency stability concerns resulted in setting a constraint in 2011, limiting the instantaneous share of non-synchronous sources of generation (wind power and HVDC imports) to 50% of demand plus HVDC exports, the so-called system non-synchronous penetration (SNSP) (O'Sullivan et al., 2014). This limit has been increased step by step, reaching a 70% trial in January 2021, and progressing further with a 75% SNSP trial in April 2021 (EirGrid & SONI, 2021; Holttinen et al., 2021 IEEE PES Magazine). Reaching high SNSP required wind and conventional generation to remain synchronized to the system at ROCOFs exceeding 0.5Hz/s. In 2021, the ROCOF limit was increased to 1 Hz/s, having previously individually investigated and assessed the ability of all generators, including embedded generation, to meet the higher ROCOF standard. Also, a suite of expanded system services has been introduced by EirGrid and SONI under the Delivering a Secure, Sustainable Electricity System (DS3) program, which aimed to incentivize the provision of faster frequency and voltage support services as well as longer-term (hours) ramping margin products. Of particular relevance to enhancing frequency stability, a synchronous inertial response product and a fast frequency response (FFR) product were introduced. The synchronous inertial response system service rewards synchronous plants based on their rotational energy (inertia) relative to their minimum stable generation level, which encourages generators to

reduce their minimum output, such that under low system demand conditions, more generators can be “squeezed” online to meet the target demand. In this way, the online rotational energy of the system is increased, and the robustness to system disturbances is improved. The FFR product encourages a “fast” contingency reserve response for a period of 8 seconds. The default response time is 2 seconds after the triggering event, but a scalar mechanism increases payments by up to a factor of 3 for response times within 0.15 second. The FFR service is open to all certified technologies, including BESS and wind power plants, although a post-event energy recovery phase must be respected, which can place limits on the initial response provided.

The future inertia levels of the Nordic synchronous system have been estimated to be 1%–19% of time below the required 120 GWs–145 GWs for different hydrological years (on average 8%) in 2025 due to added wind and solar power (Figure 46) (Statnett, FG, Energinet, SvK, 2016). The high number of HVDC links to the Nordic system also impacts the future inertia levels (Nordic TSOs, 2018).

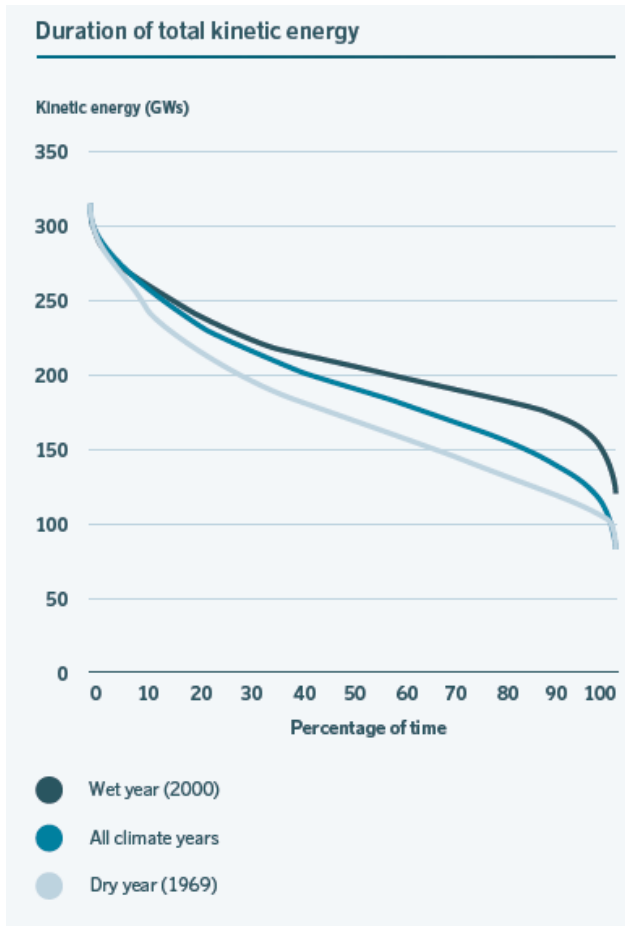

Figure 46. Duration of estimated total kinetic energy for all climate years (1962–2012) for a dry year and a wet year in the market simulation scenario for 2025 (Source; Statnett, FG, Energinet, SvK, 2016).

In the U.S. MISO area, frequency response was found to stay stable up to 60% instantaneous shares of variable renewables but might require additional planned headroom beyond.

A frequency stability study of each region of the Continental Europe system looked at the interconnected incidents in each zone and system splits (EU-SysFlex D2.4, 2020). A multi-area dynamic model, PALADYN, computes the frequency in response to imbalances. Lower frequency nadir values and higher ROCOF values were especially visible in the Iberian Peninsula, mainly because of its large share of renewables and its low connection to the rest of Europe. ROCOF values can overshoot 1.3 Hz/s in this area, which raises concerns about the stability of the Iberian generators. Other than that, no clear situation of blackout was encountered during

the year in either the Renewable Ambition scenario, which contains a 66% renewable energy share in electricity consumption (RES-E) in Europe, or the Energy Transition (RES-E share of 52%).

System splits in Continental Europe were also studied (Figure 47). The imbalances could reach very high values (+/-12 to 18 GW for the peninsulas and +/-20 to 30 GW in the “Europe in 3” split). Consequently, load shedding and the limited frequency sensitivity mode at overfrequencies mechanism appears to be the only options to maintain frequency stability. In some cases, especially for both peninsulas splits, the activation of these mechanisms could still be insufficient to avoid blackout situations (EU-SysFlex D2.4, 2020; Fournel et al., 2020).

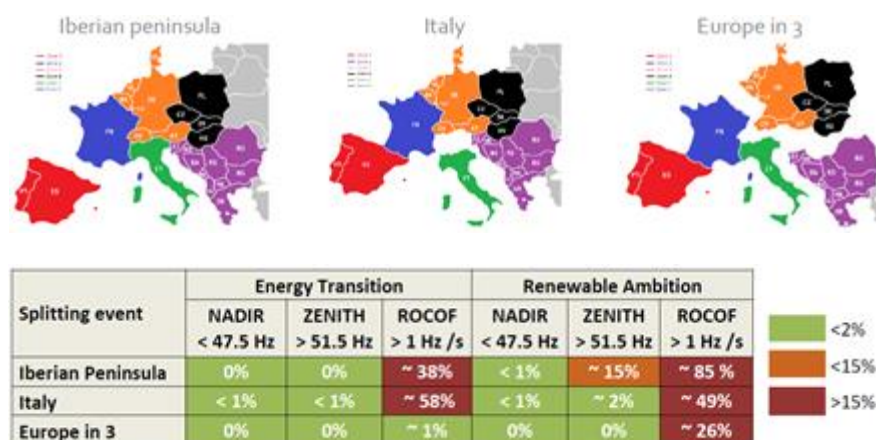

Figure 47. System splits assessed in the frequency stability study of the EU-SysFlex project (Source: EU-SysFlex D2.4, 2020).

Concrete remedies to address these issues (EU-SysFlex D2.4, 2020) include:

- Ensuring that DC links stay connected in case of system splits. In all the presented simulations, system splits imply the disconnection of both AC and DC interconnectors, which could be deemed pessimistic. Indeed, DC links could be controlled to remain connected in case of system splits. This possibility could drastically reduce the severity of the consequences of the splits and should be thoroughly explored.
- Limiting the cross-border flows to reduce the imbalances caused by the system splits
- Curtailing IBRs such as wind and solar and increasing the inertia level with conventional plants, preferably with decarbonized generation, such as hydropower, biomass, or nuclear
- Encouraging alternatives for the provision of inertia, such as synchronous condensers, grid-forming control of wind and solar power plants, or batteries.

The most cost-effective solution is likely to be an optimal mix of all these measures.

### 5.2.3 Studies for other stability issues

Voltage stability relates to maintaining an acceptable voltage profile in steady state and following a disturbance, such as an increase in load or a network fault. Voltage instability is mainly associated with an inability to meet (local) reactive power requirements, so it is dependent on the reactive power capability of generators and the reactive power demand of loads, but it is also influenced by implemented voltage control strategies, such as interactions with transformer tap changers. Consequently, when assessing voltage stability at high wind penetrations, the potential to use the reactive power capabilities of the turbines is a key determining factor.

In general, voltage stability is likely to be unaffected or enhanced by the presence of wind turbines (You et al., 2013) if the turbine reactive power control capabilities are deployed to manage voltage (Vittal et al., 2010); however, it might be appropriate, particularly in network regions where (conventional) generation has been displaced, to introduce static VAR compensators (SVCs), synchronous compensators, or similar equipment, or even to make certain generators “must run” for voltage support reasons.

As an example, Figure 48 illustrates the issue of decreased short-circuit currents due to the replacement of rotating generators with inverter-based generators in Italy by showing the widening area of the voltage disturbance.



Figure 48. The replacement of rotating generators with inverter-based generators decreases the short-circuit currents and widens the area of the voltage disturbance. Example from Italy (Source: Terna).

**For the island system of Ireland**, it was estimated that voltage and transient stability issues can be mitigated for the anticipated near 40% wind shares, and small-signal stability was not seen as an issue (Eirgrid & SONI, 2010). With new targets for renewables (70% of demand) and wind power dominating the mix, transient stability issues with a reduction in synchronizing torque are also foreseen (EU-SysFlex D2.4, 2020). Also, voltage control is becoming more challenging due to the reduction in the available reactive power resources (through displacement of conventional power plants) and the disperse location of wind power plants (with different capability characteristics), combined with increasing installation of high-voltage cables. Currently, an active transmission constraint dictates that there must be a minimum of eight large synchronous machines on-load at all times in the all-island system. To accommodate increasing amounts of non-synchronous renewable generation, this constraint must be relaxed. To provide guidance to control center operators on the best methods to manage system voltage, a new Voltage Trajectory Tool is currently being developed to determine the optimal reactive targets for different types of devices and will deliver voltage trajectory plans secure against contingency events for intraday and day-ahead time horizons (Holtinen et al., 2021 IEEE PES magazine).

In the United States, MISO performed a Renewable Integration Impact Assessment (RIIA) looking at annual renewable energy shares of up to 50%. The key findings of the study for dynamic stability are (MISO, 2021):

- The potential for dynamic stability issues due to a weak grid increases sharply beyond shares of 20% renewables.
- Small-signal stability might become a severe issue beyond the 30% renewable share and can be addressed by specially tuned batteries or must-run units equipped with power system stabilizers. Interconnection-wide small-signal oscillations ranging from 0.1 Hz–0.8 Hz can appear with high shares of renewables. Through detailed analysis, strategic locations can be identified where installing appropriately tuned and designed supplemental power oscillation damping (POD) controllers on renewable resources, batteries, static VAR compensators, STATCOM, or HVDC can help to improve small-signal stability.
- Overall, critical clearing time improves as large units are displaced, but some locations might observe a decrease and require the installation of new protection techniques or transmission devices.
- Grid technology needs evolve as renewable penetration increases, leading to an increased need for integrated planning and a blend of transmission solution types.

The analysis also indicates that to reduce the cost of grid integration at high penetration levels, there is benefit to improving the characteristics of IBRs. Better control techniques (such as deploying grid-forming inverter technology) can have the effect of reducing the need for synchronous condensers and transmission lines—both AC and DC.

ERCOT conducted dynamic stability assessment in 2018 using EMT (PSCAD) and transient stability (PSSE) simulations for operating the Texas grid with more than 70% instantaneous penetration from renewable energy resources (ERCOT, 2018). The study found several dynamic stability problems causing system-wide oscillations during operation with high levels of renewable generation. Many of these problems were attributed to the inability of existing IBRs to operate stably under low system strength conditions. The study recommended control tuning of IBRs to enable operation with weaker grids. The use of synchronous condensers was also explored to improve system strength and fault current levels to mitigate dynamic stability concerns that result from the displacement of synchronous generators by IBRs.

The role of grid strength in reactive power oscillations in wind power plants was investigated in a 4-MW wind turbine prototype from GE using impedance measurements on the turbine. Based on the extensive impedance measurement and PHIL (power hardware in the loop) testing, it was determined that the reactive power oscillations were a result of an underdamped resonance mode inside the 4-MW wind turbine (Koralewicz et al., 2020).

Key performance indicators to quantify the distance and the tendency of a power system to move to instability have been made in the EU project Massive Integration of Power Electronic Devices (MIGRATE) (Rueda Torres et al., 2017). Stability phenomena in systems with high shares of wind generation displacing bulk conventional (fossil fuel fired) power plants include frequency stability, rotor angle stability, voltage stability, and sub-synchronous controller interactions. The indicators are mapping information from key variables (e.g., power electronics-to-load ratio) into metrics (e.g., normalized voltage stability index) that reflect the sensitivity of the system to structural changes (due to increasing penetration levels of renewables) affecting its dynamic performance. The key performance indicators were tested on the reduced-size model of the Great Britain system and the Irish system, which included high shares (more than 50% from the total power share) of wind power generation.

#### **5.2.4 Impact of HVDC connections on stability**

The impact of HVDC connections on the stability of the Nordic power grid has been studied in Vrana et al. (2017a), where wind power is predominantly outside the Nordic power system, but Norway is balancing the wind power in other North Sea countries through a large number of HVDC links. Power flow simulations for a future scenario indicate that capacity and voltage constraints within the Nordic power grid will be a limiting factor for the power exchange. The dynamic simulations indicate that future high-import scenarios can give more oscillations after disturbances compared to scenarios with less import, considering generic converter controllers that are not tuned to damp these oscillations. The general system vulnerability of the Nordic grid with regard to the HVDC links has also been investigated (Sperstad et al., 2018).

## 6. Maximizing the value of wind power in operations

The value of wind power comes largely from the energy it replaces. Wind power can also help to decrease the capital cost of the rest of the generation fleet. A more flexible power system can use variable energy sources at higher value; hence, the main factor in maximizing the value of wind power lies outside wind power itself. However, wind power can also increase its value by providing system services. Especially in surplus generation situations, this helps all WPPs as sourcing system services from other power generation sources would force more curtailment of wind power. Meanwhile, extensive curtailment of variable power is an indication that the flexibility of the power system is inadequate.

In addition to the experience and results of curtailments and grid support, this section describes measures to enhance the balancing task with high shares of wind power: operational practices of grids and markets as well as different flexibility options (storage, demand-side flexibility, and thermal power plants with sector coupling).

### 6.1 Estimating the value of wind energy

The value of wind energy is often assessed as savings in the operational costs of the system operation as wind energy replaces fuel in conventional power plants. This also results in CO<sub>2</sub> reductions, which might not be accounted for unless a CO<sub>2</sub> price is set (Holttinen et al., 2015).

It was previously common to try to estimate a so-called integration cost of wind power. All the methods have been found to have serious drawbacks (Milligan et al. 2012; Milligan & Kirby, 2009; Milligan et al. 2011; Müller et al., 2018). The main caveats have been the use of benchmarking technology (finding costs needs a reference simulation to find a cost difference) as well as a way to allocate costs to wind power (for example, adding transmission will result in other benefits in reliability than only connecting and transporting wind energy). A result from a specific system cannot be generalized and cannot be used for another system. Making changes in power systems in a different order (for example, adding wind, solar, batteries, and flexible demand) has been shown to result in different costs (Söder, 2021).

Instead of trying to add a system integration cost to the generation cost (LCOE), policymakers and other stakeholders should assess the total system costs and benefits for the entire system for different scenarios. This will allow for identifying the investment needs, total operational costs, and overall system value without the need to allocate costs to specific users/technologies. The total system cost-benefit approach avoids the challenging task of isolating and quantifying wind- or solar-specific system integration costs and does not require defining a benchmark technology (WindEurope, 2018; Müller et al., 2018). This approach was applied in the Irish wind integration study (AIGS, 2008) and has been the recommended practice from Task 25 (Holttinen et al. 2018).



Recent work on a range of competitiveness metrics aims to capture the value and/or cost components of wind and other technologies. These include non-comprehensive existing metrics, such as the LCOE and the levelized value of energy and also a new category of profitability-based metrics that provide a comprehensive representation of both value and cost. By placing all grid services on an equivalent monetary basis, these new metrics provide a more effective economic comparison across different electricity system technologies. Examples include cost-benefit ratio, system return on investment, and system profit margin (Mai et al., 2021). As more and more costs are reflected in market pricing, the costs will be seen as a lower system value for wind energy—provided the market design is cost-reflective and transparent. This will incentivize the actors to make correct decisions regarding the most system-friendly way of building more wind power.

Measures to avoid or mitigate the value drop of increasing wind and solar shares can be found both in the way wind power is built, and in the way the future power and energy systems are built and operated (Wiser, 2017). System friendly wind has larger rotors and taller tower have proven to provide more system value of wind energy, as well as geographical diversity in siting and providing system services (Hirth & Müller, 2016). Wind friendly systems have flexibility in generation, demand, transmission, and storage with a market design to allow for flexibilities from all sources. The impact of electrification in stabilizing market values will also be important of capture in future assessments (Ruhnau, 2021).

## **6.2 Curtailments**

Reduction in the available wind energy can be used in critical moments when there is a surplus of energy that the power system has no other means to absorb. This form of system balancing can also be used locally to accommodate local congestion when there is not enough grid capacity to transmit energy (see Section 6.4.1, Congestion management).

Where balancing markets exist and are open to WPPs, curtailment can be performed as a service of dispatching-down power (downward regulation); see also Section 6.2. Today, most WPPs have the capability to provide downward regulation (in line with national grid codes), and it is already offered and used in the market mechanisms in Denmark, Great Britain, and Spain, as well as MISO, ERCOT, and NYISO in the United States.

From an economic perspective, the main difference between production curtailment for system balancing and the provision of downward regulation is that downward reserve providers are settled at the balancing market price, which is usually a higher income for the generators—and reflects the real-time balancing cost—and thus it sends the right price incentive. Deciding to dispatch-down wind power when wind resources are available is a lost opportunity (at a zero marginal cost because no fuel is used). In some countries, WPPs are required to curtail at a zero or negative spot price—or they will not get subsidized during those hours, giving them an incentive to shut down when there is a surplus energy situation in the power system.

Any larger amount of curtailment will indicate a lack of flexibility to accommodate wind power in the power system. In addition to experience in curtailments, this section reviews how curtailment can be used as a metric of inflexibility in integration studies.

### 6.2.1 Experience in curtailments

Experience in curtailments have been reported in Bird et al. (2016) and Yasuda et al. (2021). Curtailed energy from WPPs has been plotted against the share of wind energy in Figure 49 and Figure 50.

Curtailment is a significant challenge for renewable energy integration into weakly interconnected systems (such as Ireland); where grid infrastructure is lagging the development of WPPs (China, Germany); or where a large number of conventional generators have must-run obligations, making the supply side very inflexible (China, Japan). Italy and Texas have managed to reduce curtailments as new transmission infrastructure has come into place. The large curtailments in China have been mitigated mainly by optimizing the yearly development layouts and schemes as well as by improving the flexibility of coal-fired power plants, new power grids, and hydropower pumped storage build-out. The challenge remains to accommodate higher shares of wind where demand-side flexibility will also play a role.

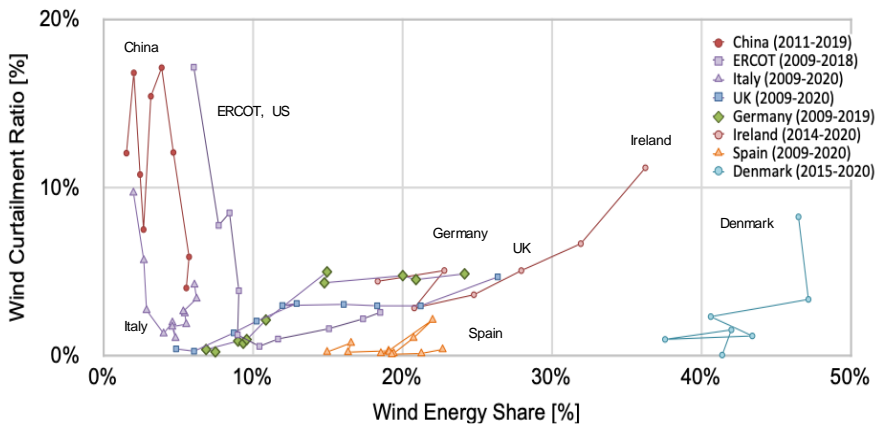

Figure 49. Wind energy curtailment in China, ERCOT (Texas), and Europe—curtailment map (Source: Yasuda et al., 2021).

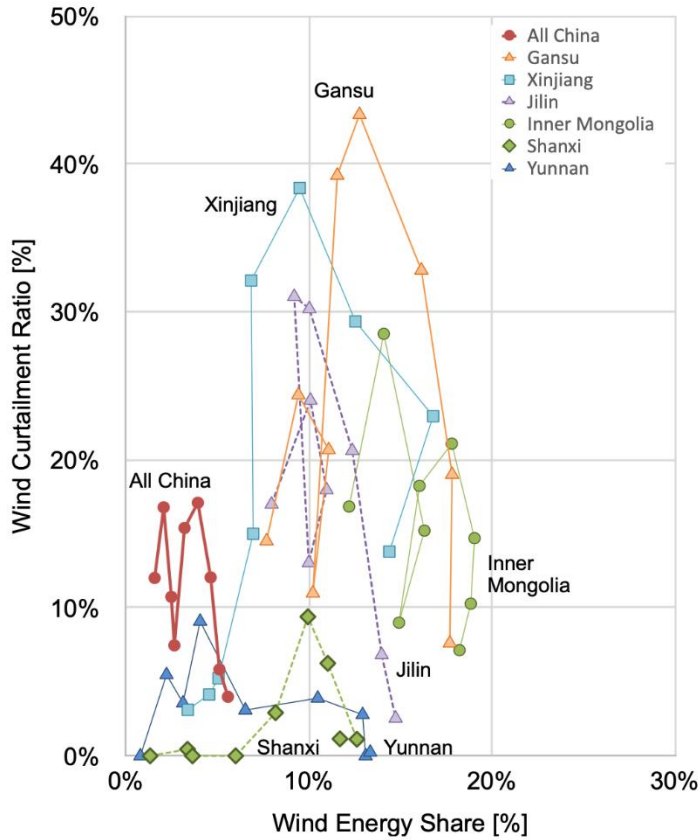

Figure 50. Curtailments in China as a function of wind energy share. A rapid increase in wind resulted in high curtailments due to inflexibilities in coal-based generation and their tariffs and bottlenecks of transmission. The curtailments were well mitigated by grid reinforcements (Source: Yasuda et al., 2021).

Figure 51 shows an example of curtailments broken down by the cause of curtailment for the whole island of Ireland from 2011 to 2019. The two high-level causes are system constraints and network congestion due to delays in building network reinforcements associated with wind power projects. System constraints include the SNSP limit as well as constraints such as high-frequency run-back and minimum stable generation constraints. The SNSP constraint was introduced into Ireland in 2011 as a result of studies suggesting stability problems at high instantaneous shares of wind power. This was originally set at 50%, increased to 65% in November 2017 (EirGrid & SONI, 2018), and further increased to 70% and 75% in 2021. In 2020, system constraint caused 5.3% curtailment and when local network congestion is also considered, the overall dispatch-down level in 2020 was 11.4% (Holtinen et al., 2021; Yasuda et al., 2021).

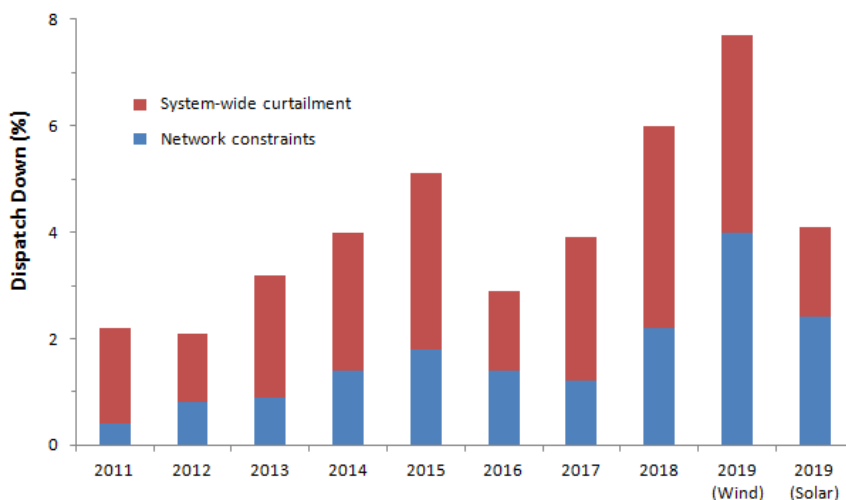

Figure 51. Wind (and solar) curtailment by year for the island of Ireland (Source of data annual reports at <http://www.eirgridgroup.com/library/>). Wind power capacity increased from 1.6 to 5.4 GW (15% to 31% of annual demand) from 2011 to 2019, with 246 MW of solar capacity installed by 2019.

Denmark has coped with high shares of wind energy with minimal curtailments so far, but in 2020 wind was down-regulated by 1.46 TWh, or 9% of the potential wind production in the Energinet area. This happened due to three different reasons: (1) 92% was due to “special down-regulation,” which is caused by congestion in the German grid and a cross-border agreement, (2) 6% was down-regulated by the owner due to negative spot prices, which is normal market behavior; and (3) 2% was curtailment according to classic understanding, i.e., due to congestion in the Danish grid. Curtailment and negative spot prices have been rather stable in recent years, whereas the special down-regulation has constantly increased. In general, surplus generation leading to curtailments can be mitigated by trade with neighboring areas (such as Denmark to Norway and Sweden). However, some surplus situations in close vicinity can also aggravate the curtailments seen (such as in Denmark and Germany).

In Germany, the delays in grid reinforcements have resulted in increasing curtailment and redispatch measures, as shown in Figure 52. The congestion management in Germany has been executed in two steps. The first step is a day-ahead redispatch process where conventional power plants are up- and down-regulated in deficit and surplus areas to relieve congestion; see more in Section 6.4.1. The second step is the so-called feed-in management process (German “Einspeisemanagement”), when renewables are instantaneously down-regulated due to grid congestion as the final emergency action. There is no equivalent up-regulation. Any remaining imbalance must be balanced by reserve power. Within the feed-in management process, approximately 5.4 TWh of renewables were curtailed in 2018. This

corresponds to approximately 2.8% of total renewable energy generation being down-regulated—in nearly all cases, wind energy (land-based 72% and offshore 25%) (see Figure 53). The total estimated compensation payments claimed by the operators amounted to approximately €635.4m. Of all curtailments, 87% result from congestion within the transmission grid, but only 26% have been executed by TSOs for renewable energy sources connected to the transmission grid, whereas distribution system operators (DSOs) have executed 74% of all curtailments (Bundesnetzagentur, 2019). Starting in 2021, WPPs will be included in the redispatch process. Consequently, down- (but also up-) regulations of renewable energy units can be planned in a predictive way.

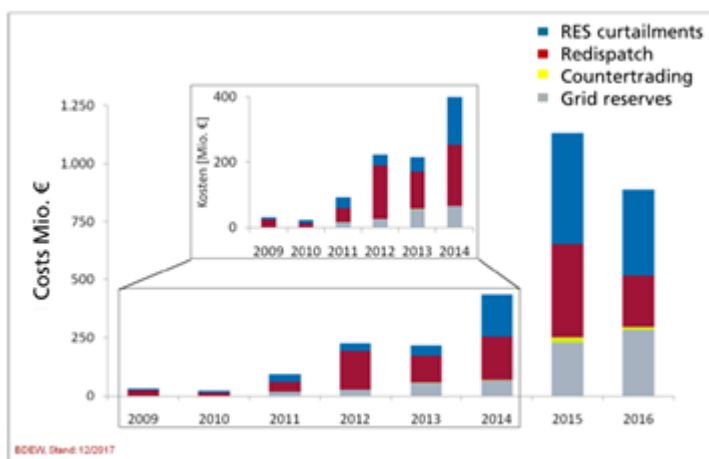

Figure 52. Development of costs for congestion management in Germany (the decrease of curtailments in 2016 is due to low wind speeds).

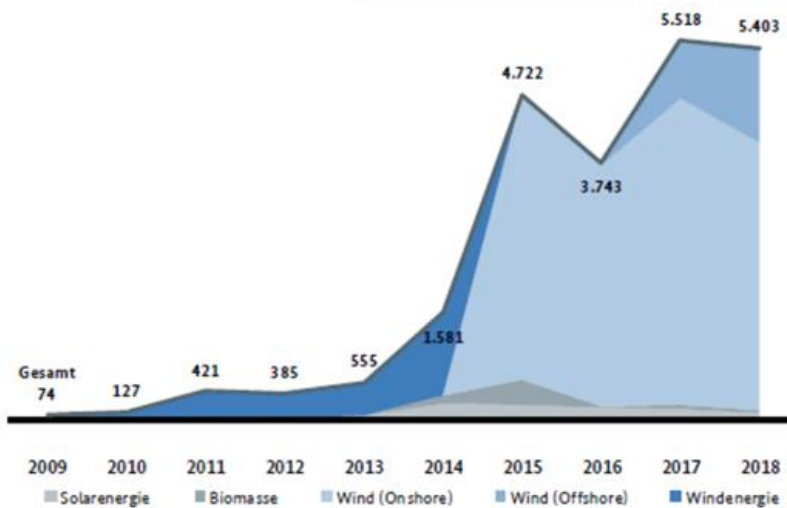

Figure 53. Curtailed renewable energy in Germany (mostly wind energy).

### 6.2.2 Estimating future curtailments in integration studies

Wind curtailments are also often calculated from wind integration study simulations for power system dispatch, showing the challenges of wind integration. For increasing shares of wind and solar, the curtailments would increase, unless new flexibility measures are introduced or transmission infrastructure is reinforced.

Curtailment of wind, and VRE in general, can be part of optimal dispatch, helping to increase the ramp capabilities and flexibility of the system. Forcing the maximum wind output could simultaneously increase costs and emissions if a more pollutive unit needs to be kept online. On the other hand, optimally dispatching wind allows wind to supply flexibility to the system, e.g., ramping wind can reduce the (residual) ramping needs of the system, thus replacing the flexibility previously provided by a more pollutive unit (Morales-Espana et al., 2021).

The results of seven integration studies with a wind power share from 30%–40% of yearly energy show that curtailments are in the range of single-digit percentages and that more transmission reduces the challenges of curtailment (Söder et al., 2017).

In Canada, the curtailment of wind energy evaluated in the Pan-Canadian Wind Integration Study was approximately 6.5% to 6.9% with 20% wind penetration. The amount of curtailment was higher in the scenarios with more wind energy, primarily due to transmission congestion. In addition to building transmission, options for reducing curtailment in Canada include shifting hydropower use where large hydro reservoirs allow for storage capacity to be used and providing more operational flexibility in thermal generation (PCWIS, 2016).

In North American Renewable Integration study (NARIS), curtailments were assessed as part of the results. For the low-cost VRE scenario in 2050, 9.3% of the potential wind and solar generation in the United States was curtailed. The bulk of the curtailment occurs in a small percentage of the hours, but curtailment occurs somewhere in the United States almost every hour, even if mainly during daytime, which coincides with the solar pattern. Curtailment represents a trade-off between the capital costs of wind and solar (or transmission and storage) compared to the fuel costs of thermal generators.

### **6.3 Using wind power plants for grid support services**

Power systems need essential reliability services (so called ancillary services for grid support) to operate reliably. During hours of high wind and PV penetration, and with fewer synchronous generators online, it is important that wind and solar power plants provide grid support services, otherwise they risk being curtailed to commit a synchronous generator to provide services.

WPPs already provide frequency support services for different timescales (primary/secondary/tertiary) in several places. For example, in Ireland, a key trend observed is that each procurement round results in an increased percentage of overall system service contracted capabilities being provided by non-synchronous technologies. It is now common knowledge among utilities and market operators that WPPs can provide equivalent services to conventional power plants, and they often provide them more rapidly and accurately. There is also increasing experience in wind plants providing ancillary services very economically during curtailment periods.

As the share of wind power in the generation mix is increasing, WPP developers and wind turbine manufacturers are increasingly facing requirements similar to conventional power plants, which are based on synchronous generators. The development is not a “wind” issue, even though that might be the focus here, because solar PV and other sources will also need to provide system support services. The adaptation process of grid codes as well as market setting for WPPs is not yet complete, and this is expected to evolve further in the future. There is still room for improvement, especially concerning international harmonization of requirements. In Canada, the gaps in provincial grid codes, which are based on international experience, were assessed in 2021 for inverter behavior during faults, ancillary service requirements, generator modelling requirements, and potential interactions with distribution-connected generation (GE, 2021). European grid codes with relevance for wind power have been reviewed, and a future outlook was derived by Vrana, Flynn et al. (2017). A generic wind power grid code to enable compliance assessment in future scenarios without deciding the geographic location was developed by Vrana, Trilla & Attya (2017) and published by Vrana, Attya & Trilla (2020).

### **6.3.1 Balancing services with 10- ... 30-minute response times**

Manually (not automatically) activated frequency control service is used for balancing, replacing faster responding automatic reserves. This is often called tertiary frequency control (mFRR in Europe), and often sourced from balancing (real-time) markets.

In the Nordic countries, the market rules for manually activated frequency response (regulation power market) enable WPPs to also participate—services from WPPs are regularly procured in Denmark.

In Spain, the participation of wind power in balancing services started in 2016, and by the end of March 2021, 17.3 GW of the total of 27 GW of wind power capacity installed in Spain had successfully passed the operational capability tests for imbalance management and tertiary reserves services. Wind power has had an increasing contribution, especially in tertiary reserves, with an hourly participation that reached -1911 MWh and 350.3 MWh for downward and upward, respectively, in 2018. For downward reserves, wind energy accounted for 14.4% of the total reserves in 2018 and 14.8% in 2019. For upward reserves, wind energy contribution is less than downward reserves, with 4.8% in 2018 and 7.5% in 2019.

### **6.3.2 Regulation/AGC/secondary response**

Tests for both wind and solar power plants show very good, fast, and accurate responses to the regulation signal. In California, a test of a PV plant in CAISO (the California System Operator) following a regulation signal showed that PV can follow a regulation signal more accurately than conventional generation (Loutan et al., 2017). In Canada, tests undertaken at the Wind Energy Institute of Canada have demonstrated similar up- and down-regulation capabilities (Rebello & Watson, 2019; Rebello et al., 2020), and also value from the service provision (Rebello et al., 2019).

Secondary control for frequency often involves a symmetric provision, providing both up- and down-regulation. Wind and PV can provide down-regulation when in operation, but they need to be curtailed to provide up-regulation. Enabling the provision of only down-regulation will enable wind and solar PV to provide more services.

In Colorado in the United States, Xcel requires all WPPs to provide AGC (Automatic Governor Control) (Chernyakhovskiy et al., 2019). Figure 54 shows an example of how a WPP being curtailed due to a surplus energy event starts providing AGC control (both up- and down-regulation to manage frequency).



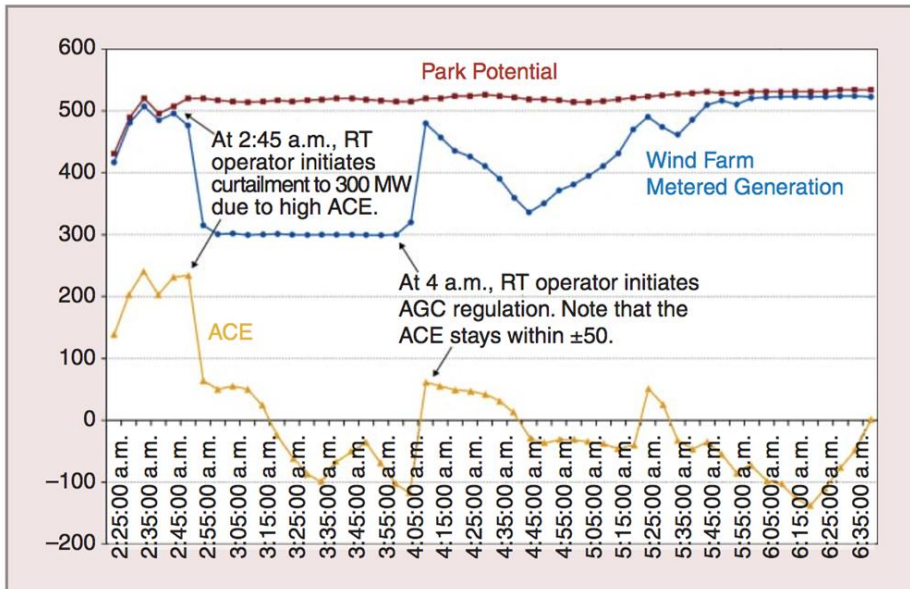

Figure 54. A WPP in the Xcel Public Service Company is first manually block curtailed and then put on AGC regulation. The Y-axis is MW. The resulting area control error is shown in yellow. (Source: Drake Bartlett, Xcel).

### 6.3.3 Primary frequency response from wind power

Primary frequency response (PFR) corresponds to frequency containment reserve (FCR) in Europe. As with all frequency services, wind and PV need to be precurtailed to provide the up-response (underfrequency). If they are operating, they can always provide the down-response (overfrequency).

This service is often required in the grid code but not always remunerated for providing the service—for example, ERCOT, Hydro-Quebec, and IESO require PFR from wind. In the United States, FERC (Federal Energy Regulatory Commission) Order 842 requires all newly interconnected generators to have the capability to provide PFR to help provide system operators with greater confidence regarding the ability of wind and solar (and other resources) to provide additional reserve products.

An example of the WPP capability to provide FCR service in Europe is shown in Figure 55 from a demonstrator in the EU-SysFlex project (Gomes et al., 2020).

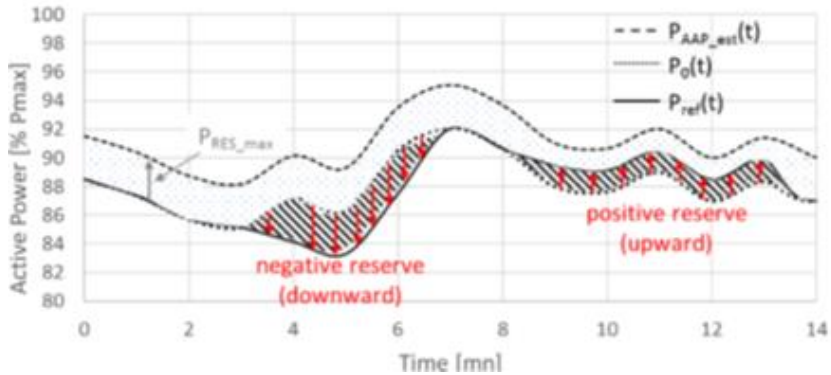

Figure 55. Illustration of symmetrical reserve provision by wind in the EU-SysFlex demonstrator (Source: Gomes et al., 2020).

In addition to operating WPPs in deloaded mode to provide grid support services, a fast active power increase in case of a frequency event can be provided, making use of the rotational energy stored in the moving parts of the wind turbine. The basic idea is to extract—for a limited period of time—an active power that is larger than the available power in the wind speed. During this, naturally, the wind turbine will slow down, and when the control is released, the power output from the wind turbines will drop below the available power level due to the need for the wind turbine to accelerate back. Ways of minimizing this recovery period—either by limiting the release or by modifying the wind turbine control—were investigated with good results in Sakamuri et al. (2017).

#### 6.3.4 Fast frequency support from wind power

Wind and PV can provide a faster, more aggressive response than the typical 5% droop. For low-inertia cases, the system needs a more aggressive response. This service has also been called inertia emulation or synthetic inertia (even if it is actually a fast control response, not a physical response like inertia). FFR is the ability of non-synchronous generators to inject real power into a grid upon sensing a change in frequency. For wind, FFR can be provided by either extraction of kinetic energy from the turbine or increased output from precurtailed wind (Denholm, 2019). As with primary frequency control, wind/solar PV should be allowed to provide this, and it should be compensated for it.

In North America, IESO and Hydro-Quebec have required fast frequency control (synthetic inertia) from wind since 2005. An event in the synchronous system of Hydro-Quebec on December 28, 2015, caused by a generation loss of 1700 MW caused a frequency nadir of 59.08 Hz on the system. Most WPPs that are required to provide fast frequency (inertial) response contributed significantly to the recovery of the system frequency (Asmine et al., 2016). Demonstration of enhanced frequency control capabilities in Canada are reported in (Rebello & Rodgers, 2021)

In Texas in the United States, system operator ERCOT has conducted simulations to show the benefits of faster frequency response over primary frequency response (PFR). This faster frequency response in ERCOT is provided by large industrial loads and enabled within 0.5 second of system frequency reaching 59.7 Hz. Under low inertia conditions (during high-wind, low-load), 1,400 MW of this faster response provide the same response as 3,300 MW of PFR (i.e., 1 MW of faster frequency response provides the same reliability impact as 2.35 MW of PFR). ERCOT has recently implemented an additional frequency response service market product called FFR (0.25 seconds response to 59.85 Hz trigger). Although wind and solar have the capability to provide FFR, they will not be eligible to participate in this new market product until December, 2021. Until then, battery storage (charging portion only) is the only resource eligible to participate. This limitation is to allow time for changes that are needed to ERCOT control room tools to enable FFR services from generation resources (Matevosyan, 2019).

Ireland requires a similar fast-responding capability, and its capability has been demonstrated in qualification trials for the time frame from 2 seconds to 5 minutes, encompassing fast frequency, primary, secondary, and tertiary reserve time frames (EirGrid & SONI, 2017). Financial incentives for the FFR service promote responses faster than the 2-second requirement (x3 scalar for response times within 0.15 second). The FFR system service has been live on the Irish system since 2018. Note, however, that in addition to wind turbines providing fast responses, solar PV plants, energy storage, HVDC systems, and demand response can offer similar capabilities (Karbouj et al., 2019).

### **6.3.5 Services for voltage support**

Wind power can also provide voltage control. Procuring steady-state voltage control from transmission-connected WPPs is already state of the art, and it is used for example in Ireland; however, providing voltage support from distribution system-connected WPPs is still new, as is providing dynamic voltage control (Sun et al, 2019).

Wind power can contribute to minimizing the losses in the distribution network by controlling the reactive power from WPPs. Analysis done in the NetVind project on a realistic 60-kV distribution system model indicates reductions of approximately 3% of the annual losses (Das et al., 2017). When combining this with the 60/10-kV on-load tap-changing DSO transformers, and 150/60-kV on-load tap-changing TSO/DSO transformer, the loss reduction can be in the range of 16% compared to the base case, as shown in Figure 56.

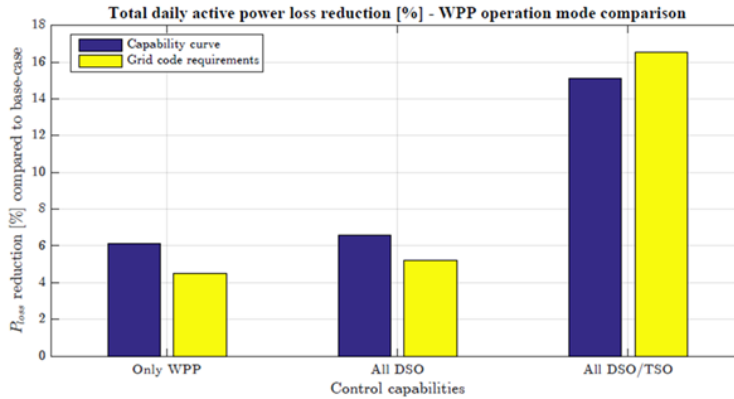

Figure 56. Active power loss reduction by controlling the reactive power from WPPs (Source: Das et al., 2017).

### 6.3.6 New services for stability support

Advanced ancillary services will be required from WPPs in future power systems where wind and solar will (at times) dominate the total system generation. Both individual new services, such as POD, and synchronizing power from WPPs are proposed, as well as having part of the WPPs as grid-forming converters, enabling system operation where most WPPs would still be operated as grid-following inverters. Restoration services, such as black start, are also studied for future systems.

#### *Power oscillation damping*

For potential issues with rotor angle stability, WPPs can be used as a damping device for power oscillations in a power system—similar to power system stabilizers in conventional power plants. The typical waveforms for these control functionalities implemented in WPPs are shown in Figure 57.

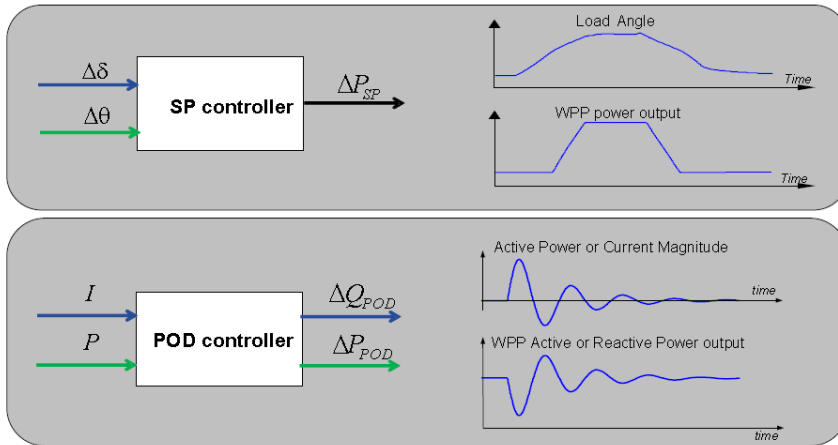

Figure 57. Overview of typical in/out waveforms of the new control functionalities from WPPs for synchronizing power (SP) and POD (Source: Sakamuri).

A WPP can be used as a damping device by modulating either active or reactive power output. The input to the POD controller can typically be a signal that reflects the power system oscillations. Two input signals—current magnitude and active power flow—were used in Hansen et al. (2015). The simulations conclude that WPPs can contribute with POD control functionality; however, the tuning of the POD control parameters is very important and depends on the input/output pair combinations and the input measurement location (remote or local). In addition, if multiple WPPs are required to provide POD at the same time, a coordinated POD parameter tuning between WPPs (by TSOs) is crucial for the small-signal stability of the power system even with the conventional power plants' power system stabilizers (PSS).

### *Synchronizing power*

Synchronizing power is an embedded feature of synchronous generators that reduces the load angle between groups of synchronous generators. If the load angle becomes too high, the synchronous generators lose torque, and the system becomes unstable. The idea of synchronizing power from WPPs is to improve the steady-state stability of the power system by giving additional power to the system from the WPP in cases when the rotor angle increases beyond a safe limit. Typically, the change in rotor angle is determined by a load change. Based on the rotor or voltage angle deviation, the synchronizing power controller increases the active power output of the WPP and thus compensates with active power the lack of synchronizing power in the system (Hansen & Altin, 2015).

One way of designing a synchronizing power controller is to use as input signals (assuming their availability) either the rotor angle difference between two synchronous generators or the voltage angle difference between two bus bars (Hansen &

Altin, 2015). Based on the simulation results presented in detail in Hansen & Altin, (2015), the synchronizing power functionality can be provided by WPPs.

### *Grid-forming capabilities*

Grid-forming inverters will be needed in the future to maintain stability in converter-dominated grids. It is likely that this will be required from variable inverter-based renewable energy source (VIBRES), such as wind turbines (ENTSO-E et al., 2020).

System operator concerns include the low supply of system inertia and fault current infeed, described as the fault level, and affecting the short-circuit ratio. The combination of these two elements is summarized by the term *low system strength*. The seven topics of concern in this context examined by ENTSO-E et al. (2020) are:

1. Creating system voltage
2. Contributing to fault level
3. Sink for harmonics
4. Sink for unbalance
5. Contribution to inertia
6. System survival to allow for effective operation of low-frequency demand disconnection
7. Preventing adverse control interactions.

These critical capabilities or behavioral characteristics must continue to be adequately delivered—even when operating near 100% penetration of IBRs—to continue to ensure stable voltage, frequency, and system angle under all operating conditions (steady state and disturbed). There still remain many gaps in knowledge in how to best use these capabilities in the power system: How effective can installations delivering some rather than all the grid forming seven characteristics be? Will having some installation with a large grid forming capability or having many installations with a lower grid forming capability be optimal? What is the minimum stored energy required for grid forming converters? Would the value be universal or varied across power systems? (ENTSO-E et al., 2020).

Today, most installed grid-connected inverters are grid-following—they measure the grid voltage as an input signal to which they synchronize with a phase-locked loop. As they follow the already existing grid voltage, they rely on something else to form it. It is intuitively understood that not all grid-connected devices can follow because there needs to be a leader as well. A grid-forming inverter produces (or forms) the sinusoidal waveform independently, and therefore it enables operation without dependence on another grid-forming entity. It also offers the potential to provide faster stability services to the grid because the response to a disturbance comes naturally and is not delayed through control loops (Hodge et al., 2020).

This capability to provide a fast and natural response is often mentioned with regard to frequency stability (virtual inertia), but it is also relevant regarding voltage stability. To provide dynamic voltage support with high short-circuit currents, however, a grid-forming converter must be rated accordingly, which significantly

increases the costs. This is in contrast to synchronous machines, which always have the needed short-term overload capability.

Drivers for studying grid-forming inverters are managing weak grids and managing events of 100% VIBRES generation. The practical feasibility of grid-forming control was studied in the EU project MIGRATE and is currently experimented in the EU project OSMOSE WP3. Basic capabilities from grid-forming inverters in wind turbines have been demonstrated in field trials in the UK (Roscoe et al., 2019).

An interesting concept for the realization of grid-forming converter control is the virtual synchronous machine, which could be a viable practical implementation. With this approach, the dynamic characteristics of the electric grid can be maintained to some degree while replacing synchronous generators with VIBRES, making the transition smoother and avoiding drastic changes in the operational strategy. Grid-forming converter control is also well suited for coping with stricter future grid codes, which could contain specifications for dynamic behavior (Vrana et al. 2017a).

#### *Restoration service from offshore wind power plants*

Modern wind turbines can meet some of the black-start and islanding requirements specified in network codes (Jain et al., 2019; Martínez et al., 2018). As larger offshore WPPs with larger wind turbines are being commissioned and developed farther from shore, HVDC transmission technology is gaining momentum over the currently more prevalent HVAC. HVDC transmission technology based on VSCs has shown excellent voltage and frequency control performance and the potential to help reduce restoration time while facilitating a safer and smoother restoration process. Denmark and Ireland already use their VSC-HVDC interconnections with Norway and Great Britain, respectively, for black-start service (Elia, 2018).

HVDC-connected offshore WPPs with black-start-capable or grid-forming Type 4 wind turbines (interfaced by fully rated power electronic converters) can be expected to perform fast voltage ramp-up and tackle the challenges in energizing cables, transformers, converters, and loads while maintaining stable, synchronized, parallel operation (Jain et al., 2018). For HVDC-connected offshore WPPs to successfully provide green black-start service during power system restoration, they must be able to deal with the reactive power requirements of inter-array cable energization; withstand the transformer magnetic inrush currents, especially those from the large HVDC transformer; and stably operate the offshore island to ultimately cater to land-based block loading after energizing the HVDC export link (Aten et al., 2019).

For large, grid-forming, offshore WPPs, the energization of the offshore network can be done using the traditionally prevalent hard-switching approach or the more complex soft-start method (Figure 58 and Figure 59). There are implications of the different natures of the approaches. Hard switching can lead to significant transients, but it provides a clear, bounded structure of the energization sequence. Soft starting can allow for a significantly faster energization process, with smaller transients, but it results in delayed fault detection and clearing, with all the implications that this entails (Jain et al., 2019).

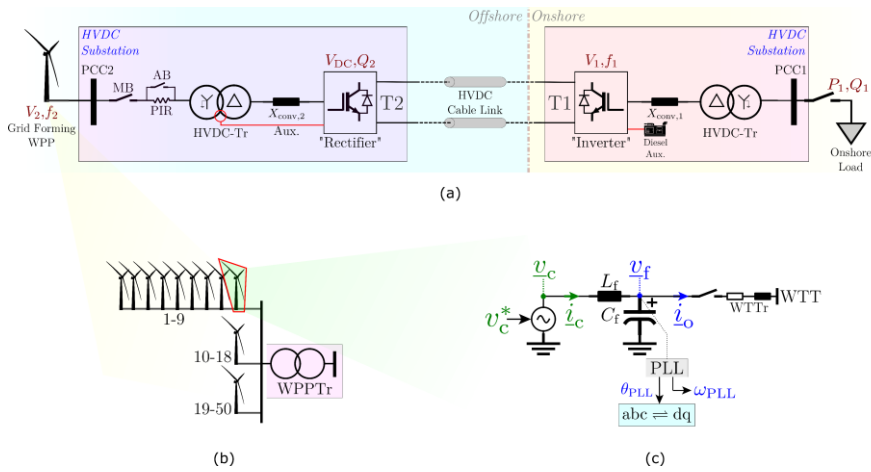

Figure 58. System under study: (a) point-to-point HVDC link, with grid-following offshore terminal and grid-forming land-based terminal; (b) partially aggregated offshore WPP representation; (c) grid-forming wind turbine grid-side network (Source: Jain et al., 2021).

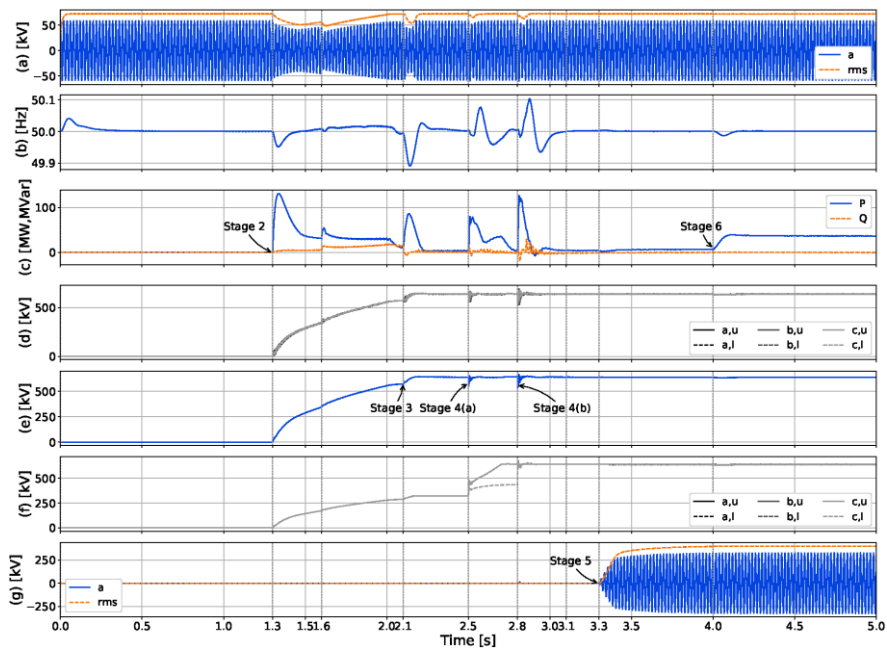

Figure 59. This figure shows (a) WPP instantaneous (blue) and RMS (orange) voltage, (b) WPP frequency, (c) WPP real (blue) and reactive (orange) power output, (d) offshore modular multi-level sum of capacitor voltages (upper/lower arm of each phase leg), (e) HVDC link voltage, (f) land-based modular multi-level sum of



capacitor voltages (upper/lower arm of each phase leg), and (g) instantaneous (blue) and RMS (orange) land-based AC voltage (Source: Jain et al., 2021).

## 6.4 Operational practices: Grid

Managing wind power in grid operation is getting more attention. All measures to reduce bottlenecks causing curtailed wind generation will contribute to maximizing the value of wind. Using near-real-time information to determine security margins, as well as active power management (phase-shifting transformers, dynamic line rating [DLR], power flow controllers), and reactive power management (reactors/capacitors, synchronous compensators, STATCOMs) is helping to make the best use of the existing grid infrastructure. Congestion management is evolving, and new ways to capture flexibility from distribution system-connected resources are being developed.

These can also be considered in transmission planning: For example, in Ireland, the network planning process includes a range of measures, including DLR, utilization of high-temperature, low-sag conductors, and the implementation of power flow controllers to better use existing networks.

Operational practices can also help in giving connection permits to WPPs. In Japan, ways of expanding renewable energy while making maximum use of the existing power networks were proposed in a concept called the Japanese version of “connect and manage”:

- For “rationalization of anticipated current,” calculate the anticipated current of the transmission lines on a scenario close to the status of actual usage rather than on the premise of all power sources operating at full capacity, and use the available capacity.
- For “N-1 power control,” restrict connection to the transmission lines instantaneously at the time of the fault, and use part of the capacity reserved for emergency use.
- For “non-firm connection,” provide a connection on the premise that the transmission is enabled when the current is small to leave available capacity in the transmission lines, but restrict it when the operation capacity is exceeded (allowing curtailments).

### 6.4.1 Congestion management

Flexibility levers used for congestion management can be divided into costly and non-costly remedial actions. Costly remedial actions such as the redispatch of generation units are used to alleviate network congestions by decreasing the generation upstream of a given congestion and increasing it downstream. This action tends to de-optimize the dispatch and generate additional costs (“congestion costs”). Wind and solar curtailment used for congestion management belongs to this category. Non-costly remedial actions include acting on some network elements to alter the

power flows on a meshed network. Modifying the set points of flexible AC transmission system units, phase-shifting transformers, or HVDC lines belong to that category. These flexibility possibilities also include topological changes (opening or closing transmission switches, splitting or merging buses, among others). These measures induce wear-and-tear costs, but their order of magnitude is much smaller than costs associated with redispatch actions.

In Germany, the need for redispatching due to congestion has been at a high level in recent years. In 2018, there were total decreases of generation of nearly 8 TWh, increases of almost 7 TWh, and the use of reserve power plants of 0.7 TWh. Redispatching measures were taken on nearly all days (354 days), and costs for operational and grid reserve power plants amounted to approximately €803m. In 2021, the redispatch process in Germany will undergo a substantial modification, allowing the renewable generators to be part of the day-ahead redispatch process, not only the real-time second step, as is the current practice.

In Italy, the challenge for large wind and solar generation is seen as the number of congested hours increases (up to 25% per year, most notably between the South and Centre South bidding zones). The increase in overgeneration from non-dispatchable renewable energy will further stress the system—estimated to reach 1 TWh for year 2030. There will also be limited availability of sources that provide voltage regulation (reactive power) and frequency regulation (rotational inertia). As a mitigation, investments in the transmission lines for the South-North backbone grid (see Section 3.2), as well as investments in active power management (phase-shifting transformers, DLR) and reactive power management (reactors/capacitors, synchronous compensators, STATCOM) have already been applied and are further planned (Figure 60). Smart grid solutions are also important, such as Wide Area Monitoring Systems (WAMS) with 120 phasor measurement units (PMUs) installed, automatic tripping devices, and real-time configuration changes as well as improving the observability of distributed generation. Distributing new investments of peaker plants and storage as well as market design to enable distributed resources flexibility will potentially alleviate congestion.

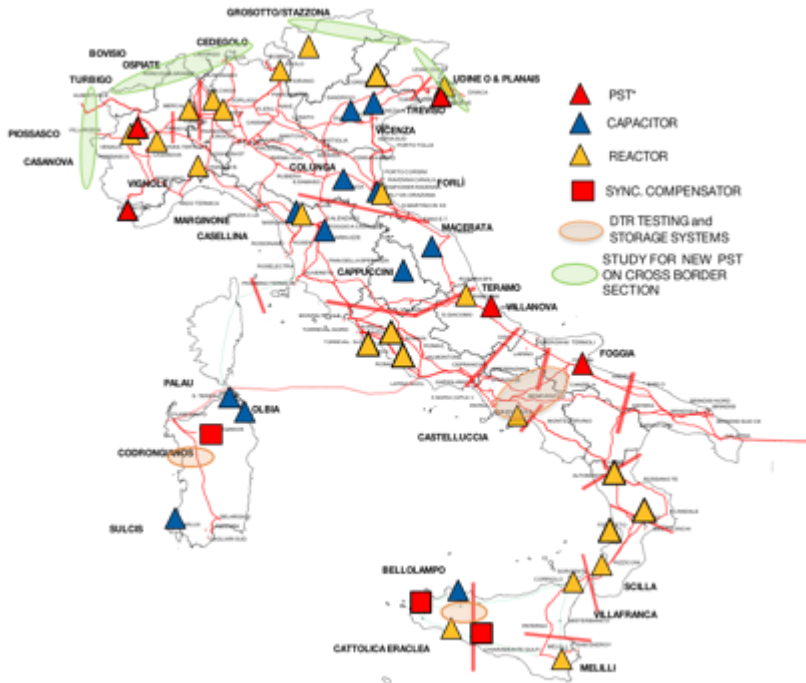

Figure 60. Example of grid investments in active and reactive power systems management in Italy (DTR = dynamic transmission rating) (Source: Terna).

In Italy, electrical battery storage pilots for congestion management tested a wide variety of technologies available on the market. The potential offered by the rapid response times of storage systems to increase the operating security margins of the high-voltage grids was demonstrated. The program tested “small-scale” solutions, so it did not show significant benefits in terms of congestion management.

Optimal topology control (OTC) is increasingly being considered as a future operational method to foster renewable integration. There is increasing value in the optimization of the transmission grid when the share of variable renewable energy increases. This is shown by Little et al. (2021) for an academic data set: the RTS-96 network, with California-like wind and solar conditions. Figure 61 compares the total cost in three different situations: copper plate (as a baseline situation overlooking grid congestion), base network with congestion management limited to redispatch (no OTC), and base network with OTC integrated into the congestion management practice. Production cost decreases as the amount of renewables increases; however, the plot shows the benefit of using grid flexibility (in blue) over alleviating congestion by only changing the generation pattern (in red). The difference in annual production cost between these two variations moves from \$40 thousand to \$66 million, more than 18%, as lower-cost energy sources are included in the system.

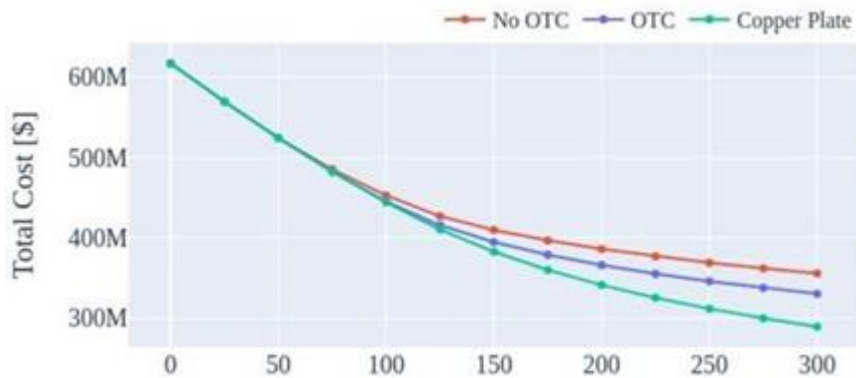

Figure 61. Total cost gained due to topological control actions as the amount of renewables increases. X-axis: Percent Wind Capacity Compared to Base Case [%] (Source: Little et al., 2021).

Figure 62 focuses on hours where thermal generation is compulsory to supply demand without OTC, either due to insufficient total renewable energy generation or insufficient grid capacity to transmit it to the consumers, and it shows the wind curtailment reduction of OTC. Under these circumstances, the copper plate case is shown to have zero wind curtailment for all scenarios (because the optimal solution is to use all renewable energy generation available), whereas any curbing of wind generation in the other two cases is due solely to network constraints. The grid flexibility actions allow for a reduction in curtailment of up to 20%. The difference in the curves continues to increase as more wind is introduced into the system.

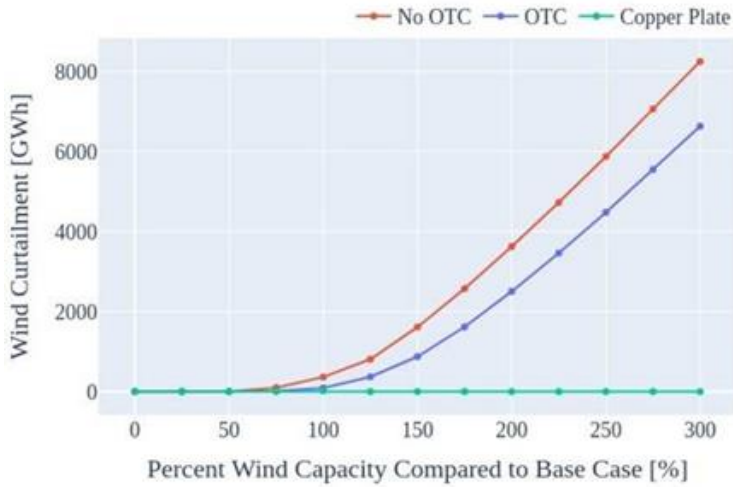

Figure 62. Sum of wind curtailment across all hours with thermal generation (Source: Little et al., 2021)

#### 6.4.2 Security margins and forecasting for transmission

In France, security margin dimensioning is made in the week ahead using both deterministic and stochastic weather forecasts. Scenarios for wind, solar, and load (50 available up to 15 days) are combined with scheduled and forced outages. For these hundreds of scenarios of stochastic simulations, system balances and exchanges are performed (considering dynamic constraints), and according to levels of risks, statistical analysis are performed (Figure 63). Information that can be used from such calculations are available margins (upward and downward), “forecasts” on international exchanges, and the efficient identification of network solutions with coordination between countries.

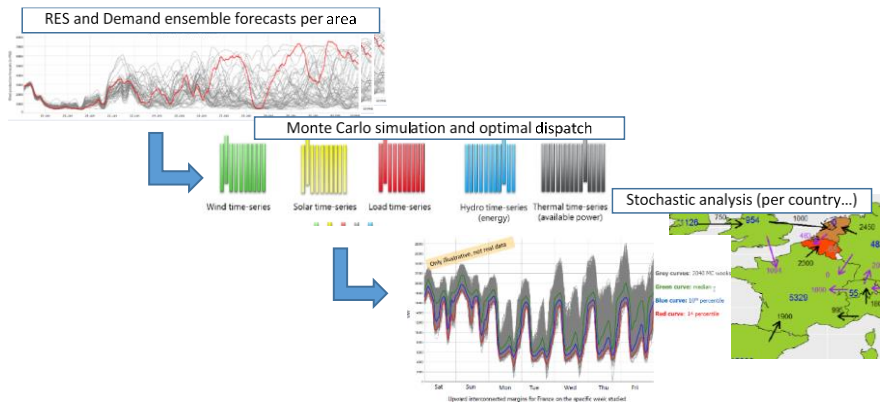

Figure 63. Weekly margins analysis—process illustration (Source: RTE, France).

In Germany, forecasting methods have been adapted to provide network operators with input data and information on uncertainty for real-time and anticipatory grid security calculations. Potentially available measurement data and weather forecasting and “now-casting” models optimized for the power industry by the German Weather Service (DWD) were used by Fraunhofer IWES building models that estimated maximum possible values, actual values, and expected values of wind and solar PV generation during the next hours and days at nodes of the German electric grid. Transmission and distribution system operators applied the system in grid management while also considering explicit measures for reducing power generation that are not weather-dependent.

### 6.4.3 Dynamic line rating

The main limiting factor for the transmission capacity of overhead lines (OHLs) is usually defined by a thermal constraint. The static line rating methodology, traditionally used by system operators to ensure that the grid does not operate over the maximum predefined conductor temperature, determines the line’s ampacity using seasonal weather conditions. These conditions usually underestimate the real transmission capacity of overhead lines. Wind speed has the greatest impact on the conductor thermal balance, followed by wind direction, and ambient temperature, with solar radiation (Duque et al., 2018). Because the wind also blows over the local power lines, besides energy production, the wind cooling effect provides additional power line capacity when it is most needed; thus, operational DLR analysis tools are increasingly used (Fernandez et al., 2016) to reduce potential line congestion.

A rough analysis for DLR benefits for European interconnectors was made in Kuwahata et al. (2019). And evaluation of hourly back-casted DLRs for the cross-border lines showed that typically a 10%–20% capacity gain can be expected 90% of the time.

In Italy, system operator Terna operates a model for multi-span overhead lines with a direct measurement on the conductor (Figure 64). The model considers the actual weather conditions (wind, sun, ambient temperature) to assess the real conductor temperature at each single span of the power line. The impact of weather uncertainty on the DLR of a transmission line is assessed using a Monte Carlo technique with tuned probability distribution functions based on the actual weather forecasting errors made in the proximity of the line. For the mechanical interaction between adjacent spans due to different loads and temperatures, a complex multi-span mechanical model of the line is included. Several case studies relevant to Italy's existing 400-kV and 150-kV overhead lines show that the steady-state rating is extremely precautionary: Dynamic ampacity is from one-third to two-thirds higher than what was suggested by steady-state calculations, depending on the season (the higher increase is in summer) and on the voltage level (the higher increase is in the transmission link). For real-time operational purposes, the dynamic rating assessed by the tool is employed in maximum current mode, and it is used by the TSO as an input for N and N-1 security analysis and optimal power flow.

There is a significant reduction in the curtailment of wind power generation due to local congestion when applying the DLR. The yearly trends of the wind energy producibility and of its curtailment in the case of two 150-kV sub-transmission lines located near big WPPs in southern Italy show that—thanks to the DLR procedure (Figure 64) applied from September 2012—the real rating of the line was systematically fully exploited, and the curtailed wind production was reduced by one order of magnitude with respect to the previous years. In 2013, the total annual producibility curtailed fell by 95% for one of the lines and 70% for the other line compared with 2012. In following years, energy curtailments remained below the 2013 level despite a 12% increase in installed capacity along the second line.

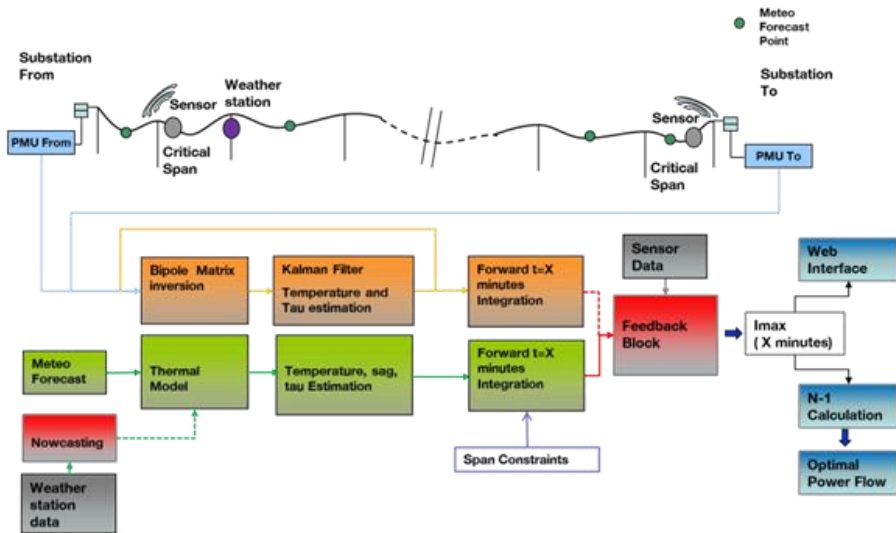

Figure 64. System architecture of Dynamic Line Rating adopted by Terna (Source: Terna).

In Portugal, a DLR analysis based on year 2016 grid and meteorological data showed that the DLR power capacity values are above the design limit approximately 66% of the time in a region with high wind power potential and approximately 82% of the time in a region with high solar PV potential; see Figure 65 and Figure 66 (Couto et al., 2020).



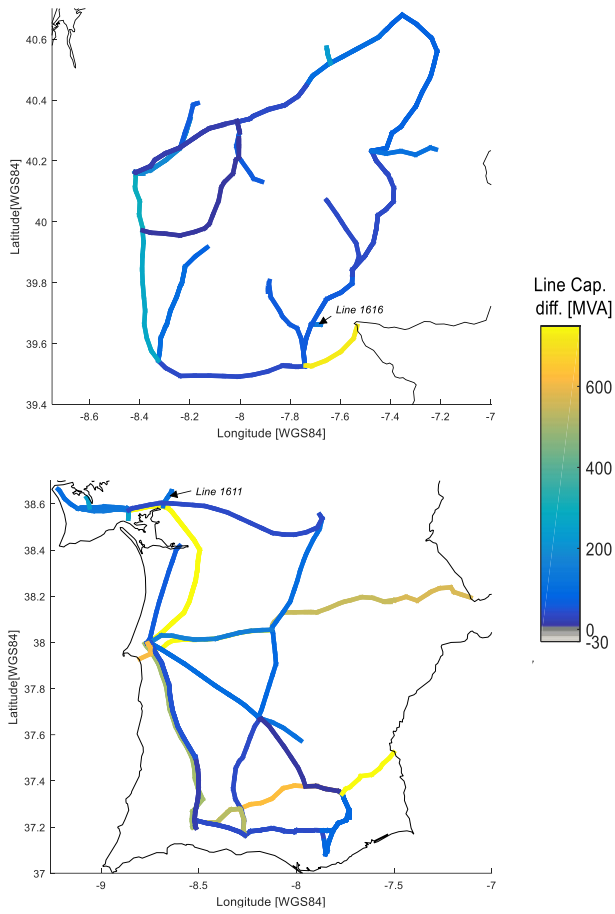

Figure 65. Line capacity differences for a region with (top) high wind power and (bottom) solar PV potential in Portugal.

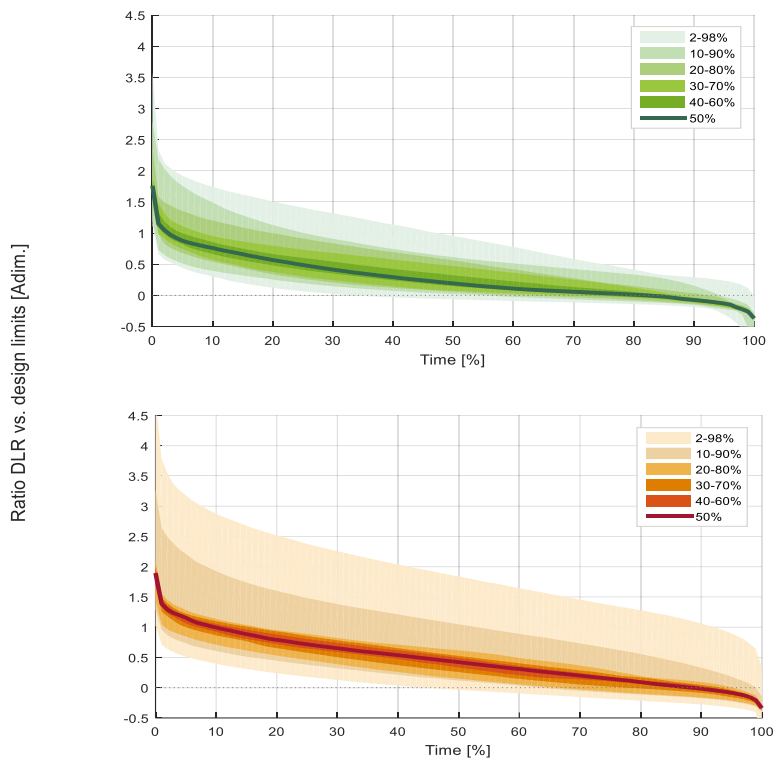

Figure 66. Normalized ratio between DLR analysis against the design limits for (top) Case Study A (high wind power) and (bottom) B (high solar PV)— percentiles of lines (green and orange scale) and percentage of time associated during an entire year. Example from Portugal.

In Germany, two different methods enabling a high degree of accuracy in the relevant meteorological parameters along power circuits with as little as possible weather measuring stations were analysed. One approach focuses on the individual circuit and determines meteorologically caused bottlenecks, so-called hot spots, along the considered power line, at which weather measurement stations should be subsequently implemented. With the other method, an entire network area is considered, and representative measuring locations are identified that are suitable for as many circuits as possible in the network area. For the development and validation of the methods, different earthbound and satellite-based meteorological measurement and model data are used as inputs into an optimization algorithm. For the two methods, it has been investigated how much benefit can be obtained when the temperature, wind speed, and solar radiation are known, depending on the length of the line and the topography of a region. The results show that up to 75% of the time,

the circuits can be used at approximately 20% higher capacity when using one of the methods. For individual circuits, increases of more than 50% are even possible many times; however, such an increase must also conform with all other grid assets. Parts of the new methods are already being used in network operation and have proven their suitability (Dobschinski & Kanefendt, 2020).

#### **6.4.4 Transmission and distribution system operators' coordination**

Many flexibility levers used by TSOs to balance the system or to solve transmission grid congestion are connected at the distribution level (such as distributed generation and demand-side management). With the increase in distributed renewable energy (especially PV and/or prosumers), coordinating congestion management and balancing between TSOs and DSOs will need more focus.

DSOs have expressed concerns that activating sources of distributed flexibility are beyond their control could jeopardize the security of the distribution grid. In addition, DSOs plan to use these new sources of flexibility for their own needs to avoid or delay investments in the distribution network; however, restricting the use of local flexibility for local grid management would represent a huge loss in balancing opportunities at the national (and European) level. Balancing is essential to ensure the safe operation of the power system (and hence the security of supply). Switching from a zonal to a local balancing would theoretically induce higher balancing costs because achieving a large-scale optimum is always better than the sum of local optima.

In parallel, other actors could seek to take advantage of local flexibilities. This is typically the case of aggregators who will try to value them on national (or even European) markets—for example, on the spot or on the future reserve-sharing platforms in Europe (TERRE and MARI). Although their impact is currently quite limited, it will probably increase with the massive development of electric vehicles or self-consumption (RTE-Avere, 2019). Further, the development of aggregators will offer new balancing opportunities for market players, reducing the balancing costs for the benefit of all customers.

The key issue is to strike a balance between local congestion management and the efficient and flexible access to balancing parties' offers. Discussions are ongoing between TSOs and DSOs to ensure the secure operation of the distribution network without restricting the access of nonlocal actors to distributed flexibility. General guidelines for their common action have been published by TSOs and DSOs in 2019 (TSO-DSO, 2019). In France, RTE is investigating the technical means of coordination with the French main DSO Enedis to ensure that distribution network levers remain available for balancing purposes without inducing unmanageable local congestion. In this respect, France is a special case in Europe, with a low-voltage level limit between TSOs and DSOs. This implies that RTE operates parts of networks in other European countries that are considered to be distribution grids.

A flexibility hub platform was developed in EU-SysFlex to coordinate the provision of active and reactive power connected on the distribution grids to cope with TSOs' requests on a market-oriented and social welfare basis. The flexibility hub

also performs as a data exchange platform for characterizing the transient response (voltage and frequency) of distribution grid-connected renewable energy sources in an anonymous and aggregated form. To achieve such fulfilment, a module for deriving the dynamic equivalent of distribution grids has been developed, allowing for annual updates of characteristics to be further considered by TSOs (EU-SysFlex D6.3, 2019).

Local flexibility markets are also emerging, as discussed in Section 6.5.1.

## **6.5 Operational practices: Market design**

Operational practices can enable larger shares of variable renewables in the power system and can reduce extra costs seen in the operational timescale. One way to change operational practices is through markets. In this section, the challenges for market design are presented from both the system and WPP operator point of view. Market design to enable system services from wind and solar power plants provides not only a system-level benefit but also a potential new revenue streams for wind and solar power in market environments. Market design to allow higher scarcity prices will help cost recovery as well as help incentivize demand response and other flexibilities to cope with both surplus and scarcity situations and wind power cost recovery.

### **6.5.1 Challenges and solutions for electricity markets with high shares of variable generation**

In addition to very high shares of wind and solar (and low shares of conventional dispatchable generation), the market design will need to adopt to adding flexibility from distributed resources, such as the demand side, as well as smart energy sector coupling. There will be more complexity from the large number of resources from the distribution side as well (EU-SysFlex D3.2, 2020).

Key market challenges for Europe include (1) the merit order effect and missing money problem; (2) the integration of new smaller and variable assets to energy and ancillary services markets; (3) the design of an effective carbon emissions market; (4) capturing of full value of (distributed) flexibility resources; and (5) geographic integration of different market segments, including the development of the harmonization of the pan-European markets and the coordination of emerging local energy markets (Strbac et al., 2021; <https://traderes.eu/>).

Prioritization of challenges and research opportunities for market design from the U.S. independent system operators (ISOs)/regional transmission organizations (RTOs) resulted in:

1. Incentivizing reliability services and operational flexibility
2. Integrating new and emerging technologies in wholesale market operations
3. Resource adequacy and system resilience
4. Energy price formation
5. Transmission–distribution coordination and wholesale–retail interactions

6. Transmission expansion planning and financial transmission rights.

Relevant items for wind deployment are capacity credit methods, minimum offer price rules, and operating reserve rules (Sun et al., 2021).

Markets are gradually adapting to facilitate the wide-scale integration of variable renewables by:

- **Adapting fast co-optimized energy and ancillary services markets with dynamic reserve setting** (Riesz et al., 2018): When high volumes of flexibility reserve are required, with much uncertainty surrounding their deployment, rolling optimization is valuable, whereby updated dispatches are generated based on the current status of the plant and current system needs.
- **Incentivizing flexibility:** In Denmark, the system operator Energinet lists a number of actions to give incentives for flexibility by market-based solutions: (1) a flexible settlement (which requires rolled-out electricity meter delivering hourly data); (2) the implementation of aggregator role in the market; (3) demand flexibility; (4) an increased price cap; and (5) markets coupling of reserve markets.
- **Reflecting transmission capacity allocation in the market design** to avoid a split between the reality of grid management and its perception by market players. System operators use power flow control devices, redispatch, and even some topology control for congestion management, ensuring the security of the grid in near real time. Their integration in the electricity market framework remains incomplete due to the increased mathematical complexity they induce on the market algorithms. In France, the system operator RTE highlights the benefits of these tools as the inherent system variability increases, not only from a security perspective but also economically. Flex-in-market design is a proposal by Elia (2019) for European market coupling to enable more efficient use of the grid at a European level by integrating redispatch actions into the market coupling and thus allowing the market to have better control of the flows in line with physical constraints.
- **Introducing faster responding reserves and other new services:** This was implemented in 2016 in Ireland, in 2020 in Texas in the United States (ERCOT FFR product response time 0.25 second), in Italy (fast reserve demonstration bidirectional service within 1 second after activation), and in the Nordic power system (FFR response within 1 second). In Ireland, ramping margin services (RM1, RM3, and RM8) over various time horizons out to 16 hours have been launched. The dynamic reactive response and fast post-fault active power recovery services to provide responses to voltage disturbances have been introduced but not yet procured. In Ireland, product scalars are incorporated to define the need, for example, based on temporal scarcity during times of strong system need, for performance, continuous response, faster response, enhanced delivery, and for location. The U.K. National Grid Electricity System Operator has introduced a process of pathways to future markets and services. The stability pathfinder is for the immediate needs of

national inertia and the local short-circuit level needs in Scotland, and the constraint management pathfinder is for resolving network constraint issues and reducing balancing costs. <https://www.nationalgrideso.com/future-of-energy/projects/pathfinders>

- **Treating wind and solar resources more like traditional generators**, specifically in how these resources bid into the market, which can impact price outcomes. In the United States, market areas are increasingly looking for ways to improve market efficiency. One example is the SPP market region, which is considering a requirement for wind and solar to offer at a specific level of their forecasted generation in the day-ahead market to enable more accurate and economic operations of the overall fleet. SPP is also investigating mitigation measures to override unduly negative wind offers, which are increasing congestion and negative prices in certain areas (<https://spp.org/documents/60323/hitt%20report.pdf>).

#### **Paradigm shift of distribution grids impacting the market design efficiency:**

The role of distribution grids has very often been neglected by market designers, but it is beginning to have a fundamental impact on the efficiency of market design. Developments of different experiments enabling local flexibility show examples of the paradigm shift:

- Distribution and transmission grid markets that are fully separate (e.g., Piclo Flex in the United Kingdom)
- Markets where only DSOs and TSOs can buy (e.g., EN-ERA in Germany)
- A common platform between DSOs and TSOs with locational bids (e.g., GO-PACS in the Netherlands)
- Markets open to DSOs, TSOs, producers, and consumers, with links to existing markets (e.g., NODES from Nordpool).

### **6.5.2 Market design to enable wind power integration**

Market rule development toward faster markets covering larger areas with possibilities to bid in small amounts of power and cost-reflective imbalance payments enable wind and solar to get the most value for their variable generation. Also, the subsidy schemes for variable generation need to be developed to reflect the market operation (Market4RES, 2016).

There are some ways to increase the value of wind energy in the market setting by reducing the imbalance costs: shorter times between bids (gate closure) and delivery and aggregating wind turbines/power plants and forecast bidding strategies using probabilistic forecasts. Also, bidding balancing products could bring extra income during certain hours.

Allowing wind and solar to bid balancing services, frequency control, and other essential reliability services (which is a more fit terminology for ancillary services) requires market design changes: using shorter gate closure times for the services (such as 1 hour ahead in Europe); smaller-sized bids; and the possibility to bid down-regulation separately (instead of symmetrical up-/down-regulation bids).

There are ongoing discussions in which grid support services are mandatory requirements and which are remunerated, and the trend is toward market-based measures. This is good for the wind industry, given the costs that it would imply to upgrade WPPs with the capabilities to provide ancillary services. It is important to ensure market continuity for these services and to adapt product design specifications and procurement rules to allow for the provision of services in a competitive and nondiscriminatory fashion from new market players (renewable energy producers, storage providers, demand-side response) (Figure 67).

## The ten commandments on balancing markets: Key design features

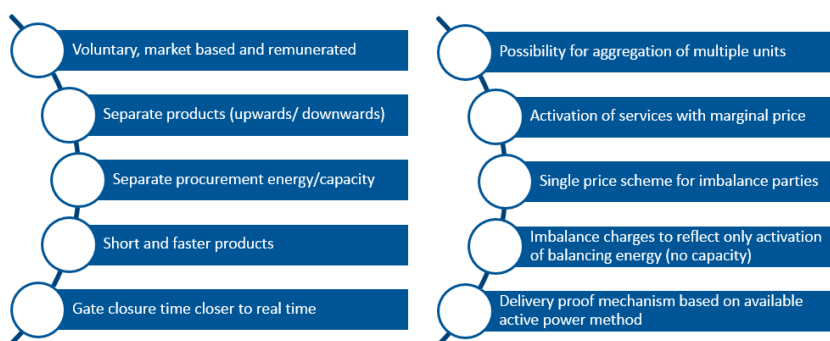

Figure 67. Top 10 market design recommendations to enable more competitive and effective balancing markets (Source: WindEurope, 2016).

An example for market operation of a wind power producer in Portugal shows how market income for wind approaches a hypothetical “perfect forecast” as these measures are taken (Algarvio & Knorr, 2017). This will reduce the need for incentives for investing in wind power; see Figure 68.

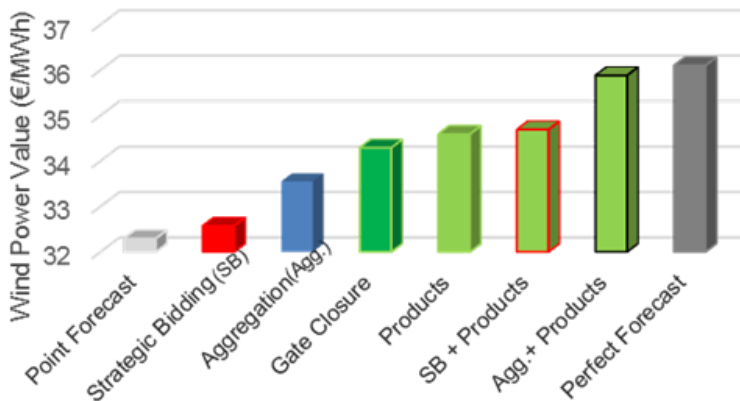

Figure 68. Increasing wind energy value to the market using different approaches: strategic bidding based on probabilistic forecast (SB), aggregation (Agg.), shorter gate closure, and balancing products (Source: Algarvio & Knorr, 2017).

### 6.5.3 How to increase market value for wind energy

The value of wind energy from selling the generation in (day-ahead) electricity markets will be impacted by not only how much wind is available at higher demand and prices but also by how much flexibility there is during surplus generation to avoid price drops when a lot of wind is available. Cost recovery from energy-only markets for future wind- and solar-dominated systems is still subject to research—changes in the market setting will impact future income to wind producers and will reflect the value that wind energy has for the power systems.

Adding a zero marginal cost generation such as wind and solar to the electricity markets will suppress the market prices during the hours they are available in abundance (the merit order effect). This will reduce the market prices for all, but more for wind and solar because their generation is more concentrated in the same hours (the “cannibalization effect”). In Europe, the impacts of wind on prices have been reported from several countries, including Denmark, Germany, Portugal, and Spain (Strbac et al., 2021); however, overcapacity is another reason for low prices in markets. In the United States, low natural gas prices have been driving coal and nuclear out of the markets even more than wind power (Mills et al., 2020).

Figure 69 shows an example of a European-wide market value factor for different shares of variable renewables (wind and solar, VRE) in the power system (EU-Sys-Flex D2.5, 2020). The market value factor drops sharply with increasing shares, in particular for solar. The solar market value factor drops from 93% at a VRE share of 23% to 36% at a VRE share of 55%. This is because solar production is concentrated in the middle of the day and leads to a drop in system marginal costs. Wind generation is more spread out during the day, and the market value for land-based (offshore) wind drops only from 97% (98%) at a VRE share of 23% to 76% (81%) at a VRE share of 55%. Even if a part of the electrification demand flexibility is already



considered in the Renewable Ambition scenario, additional demand flexibility might change the value of wind and solar and the total cost of the system (EU-SysFlex D2.6, 2021).

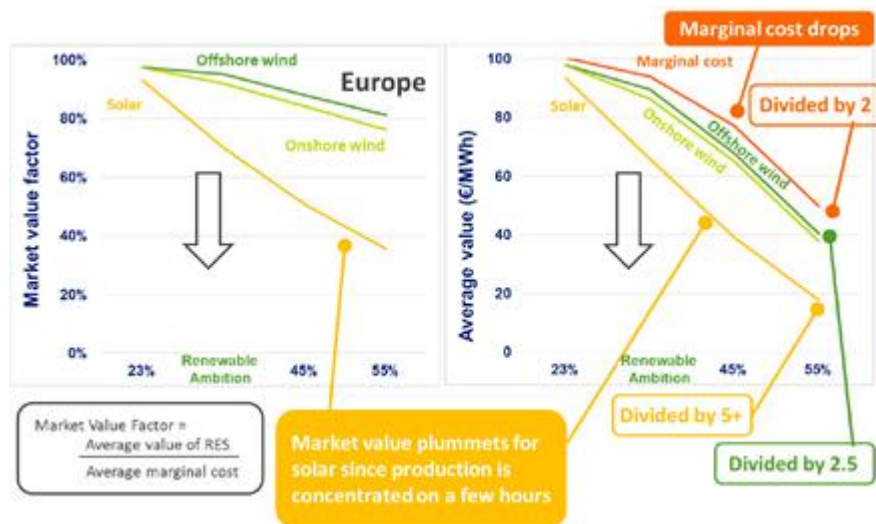

Figure 69. Average value in €/MWh (right) and market value as a percentage of average market price (left) for solar, land-based wind, and offshore wind depending on the share of VRE in the European power system (According to the Renewable Ambition scenario with 66% share of VRE, Source: EU-SysFlex D2.5, 2020)

In Denmark, the Danish TSO Energinet carried out a study of the importance of flexibility measures for the large-scale integration of VRE in the Danish power system. The measures explicitly investigated were the flexibility of thermal power plants (coal and gas) and the number and capacity of market-dispatched flexible interconnectors to neighboring countries (DEA, 2018). The study was based on simulations with a detailed model for the power system. The results show how flexible power plants and interconnectors contribute to:

- Reduced CO<sub>2</sub> emissions
- Reduced generation from thermal power plants
- Reduced curtailment of wind and PV
- Higher prices in the spot market for VRE (wind and solar) and for the flexible power plants
- Improved contribution margins (revenues minus costs) for VRE and power plants
- Overall economic surplus for the society at large even though the consumers pay a moderately higher spot price.

The study demonstrated that without the developments in power plant flexibility and transmission capacity with neighboring countries, it would be extremely challenging

to integrate VRE to the level Denmark has today. Without flexible power plants (Scenario 2), with reduced interconnector capacity (Scenario 3), and with combined flexibility reductions (Scenario 4 = Scenario 2 + Scenario 3), the market prices obtained by stakeholders would have been reduced compared to the present flexible system—e.g., market prices obtained by wind would decrease by 30% and 34% in scenarios 3 and 4, respectively (Figure 70).

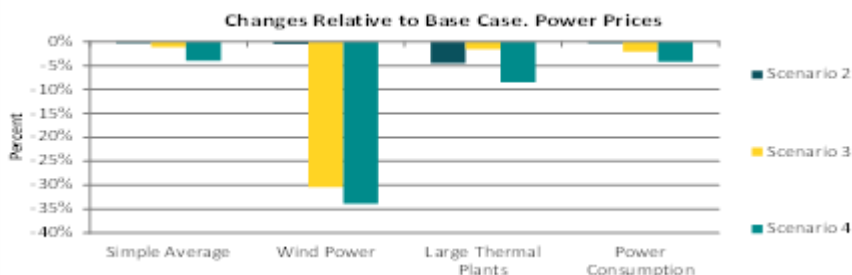
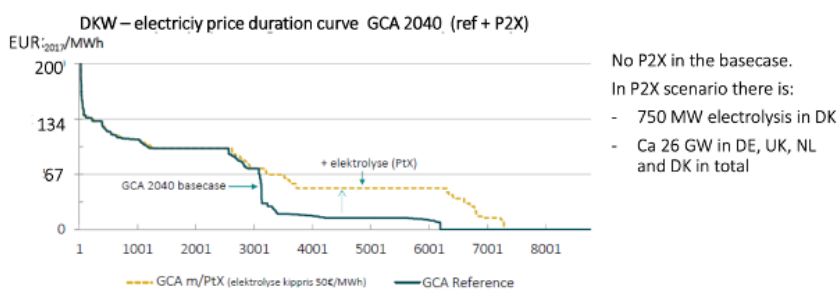

Figure 70. Changes in market prices in the case of the non-flexible system in Denmark.

Adding more flexible demand (such as electrification as well as smart system coupling from the thermal, transport, and industry sectors) will drastically change this picture—if the new demand will be flexible enough to efficiently use the surplus energy available. An example of how this can impact future electricity market prices is shown from Denmark in Figure 71.

ENERGINET

## P2X CAN INCREASE THE VALUE OF WIND/ PV



The average annual settlement price for wind and PV in DKW increases from ~20 €/ MWh to 40 €/ MWh in the P2X scenario

Sector Coupling in DK and EU - Antje O. Ihs

Oct 02, 2019, Bucharest, Romania

Figure 71. Example from the price area of Denmark West (DKW) on how future Power to X electrolyzers can improve the low prices during surplus hours (Source: Energinet).

#### 6.5.4 Increasing revenue sufficiency from energy-only markets

In energy-only markets, the revenue sufficiency of power plants depends solely on their income from selling energy (with some additions from selling ancillary services). If prices are suppressed—as we have seen through adding zero-marginal-cost wind and solar—the revenue sufficiency of the power producers could drop to a level where they will retire from the market. This could happen even though their contribution would still be needed during some critical hours in the year, which makes this issue relevant for resource adequacy as well.

Although variable generation is likely to suppress wholesale electricity prices in the short term, the prices would rebound if the generation portfolio readjusts over the longer term with less baseload generation and more peak load generation. Unsurprisingly, there would be more hours with both low and high prices. This means that occasional high prices are a feature and not a bug. Without this price signal, some cost-effective demand response might not be considered.

For an ideal short-term electricity market based on marginal cost and scarcity pricing, it was shown that all units—including VRE and electrical energy storage (EES)—recover their costs and maximize their profits in the system optimum (Korpås & Botterud 2020). This was shown for all studied combinations of technologies and operational strategies. An analytic approach was used where generation capacity portfolio planning is formulated as a least-cost optimization problem, and analytic expressions are derived for the optimality conditions for dispatchable generation, VRE, and EES using a generalized net load duration curve approach. The results indicate that the net load duration curve models can be a useful supplement to more detailed simulation studies of markets with high shares of VRE and EES to better understand the underlying factors that determine the optimal capacity mix and profitability of each technology in energy-only electricity markets.

**CO<sub>2</sub> prices** can be used to keep the electricity price levels higher. They were shown to strongly influence average prices even in a power system with little remaining fossil-fueled generation but ample reservoir hydropower generation, as shown in Figure 72 (Helistö et al., 2017).

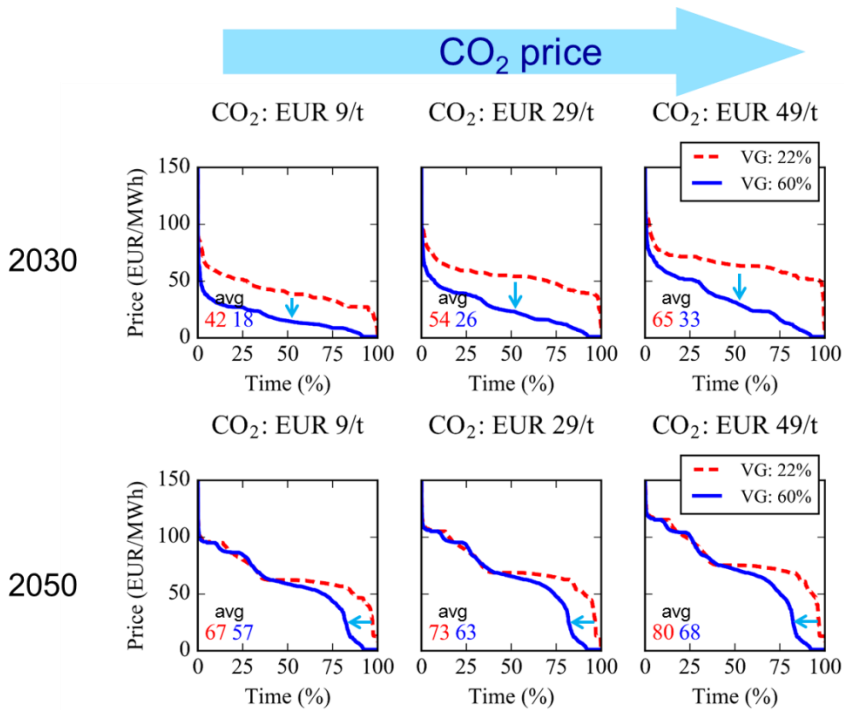

Figure 72. Estimated energy-only market prices for year 2030 with considerable overcapacity and for 2050 with a tight capacity margin—the impact of increasing CO<sub>2</sub> prices and an increased share of variable generation (wind and solar). (Data source: Helistö et al., 2017).

**Scarcity pricing.** In ERCOT, a dynamic operating reserve demand curve was implemented in 2014 that provides a price adder to the energy price that is based on the LOLP throughout the day. The use of an operating reserve demand curve (ORDC) values all available operating reserve capacity in the short-run time horizon based on the value of the lost load and the LOLP. When operating reserves drop to 2,000 MW or less, the ORDC will automatically adjust energy prices to the established value of the lost load, which is set at \$9,000 per megawatt-hour (MWh), as illustrated in Figure 73. As long as reserves exceed the 2,000-MW trigger, the impact to energy prices will be less because an outage is less likely. The intent here is that when reserves fall below the minimum contingency reserve, the ORDC sets the price for marginal capacity at the maximum. Another important aspect of the ORDC and how it differentiates from shortage pricing in other markets is that the demand curve extends (albeit at very low price) well beyond the normal reserve requirements such that there is always some adder to the energy price.

## Operating Reserve Demand Curve (ORDC)

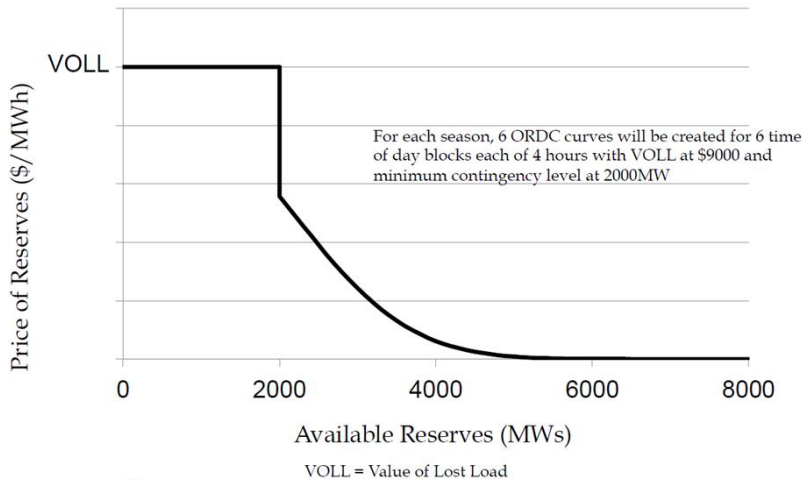

Figure 73. Providing scarcity signal to balancing resources—operating reserve demand curve used by system operator ERCOT in Texas, United States (Source: Surendran et al., 2016).

The ORDC price adder resulted in the maximum \$9000/MWh real-time price in some hours in August 2019. Additional wind deployment and cooler summer temperatures in 2020 avoided any scarcity pricing events and reduced the annual average energy price from \$38/MWh in 2019 to \$22/MWh in 2020 (<https://www.eia.gov/todayinenergy/detail.php?id=46396>).

**Ensuring more demand flexibility for scarcity hours:** In the longer run, the massive availability of low-price energy should foster electrification (the switch from existing industrial consumption to electricity and the development of new electricity uses). Provided these new loads are flexible enough, a power system can be envisaged in which price formation would be based mainly on demand flexibility in the face of a largely non-dispatchable power supply. This phenomenon would contribute to reducing price spikes, as well as zero-price periods, and hence the financial risk for investors. Power-to-gas units (electrolyzers) are a good example for such installations. For example, developing the production and storage of low-carbon hydrogen could provide an additional flexibility solution to the power system, which is particularly interesting in power mixes with high shares of VRE (RTE, 2020).

## 6.6 Flexibility

Flexibility in power systems is the enabler to wind integration and will be crucial in increasing the value of wind energy in future systems. This section presents results from adding flexibility from the storage, transmission, demand response, and heat sectors as well as results from studies comparing the value of different flexibilities. There are many studies on the capability and value of storage and demand response providing grid support services; here, studies with a link to increasing levels of wind and solar are included. In addition, the methods to assess the adequacy of flexibility are described.

### 6.6.1 Adequacy of flexibility in future power systems

The adequacy of flexibility is an emerging topic for system operators in both planning and operational timescales. In power systems, flexibility can be defined as the ability to cope with variability and uncertainty in generation and demand.

In the United States, the flexibility assessment tool InFLEXion assists planners in determining the needs of the system for flexibility (EPRI, 2019). Methods to determine flexibility requirements are based on the ramping of the net load. Ensuring that flexibility resources are sufficient to meet such requirements is based on a detailed simulation of power system operations. Flexibility metrics calculated include “periods of flexibility deficit” (the number of periods when ramping is less than required based on statistical analysis) and “expected unserved ramp” (total amount of ramping (MW) that could not be met). In addition to calculations of the metrics and ramping needs by hour of day or time of year, this section provides discussions of how planners should interpret results from flexibility studies.

In Portugal, the system operator REN includes flexibility assessment in the long-term adequacy assessment of the generating system. The PS-MORA model is based on sequential Monte Carlo simulation and includes energy and reserve scheduling with limited net transfer capacities. In addition to estimating the performance indices for the capacity of the generation fleet within interconnected areas to meet the forecasted demand, such as the loss-of-load expectation and the expected energy not served, it assesses whether the technologies available can offer enough flexibility to cope with unplanned outages of the units committed for operation or short-term fluctuations of the renewable power production and demand. The flexibility is especially important to assess in systems with a large share of hydro-power with storage capabilities, and it can embed up to 40 years of historical hydrological series encompassing a variety of hydrologic conditions, along with series for other renewable production, such as wind and solar power. The tool can include models for limiting the weekly/monthly hydro generation used and models for scheduling pumped-hydro storage to minimize the renewable energy spilled. This tool is currently being upgraded to include demand response, the representation of outage events in the transmission network equipment, and to enable fast computations through parallel processing.

The International Renewable Energy Agency (IRENA) FlexTool analyzes the flexibility of the given power system using an optimization model to show when the system would have insufficient capabilities to meet the demand. The input data have been kept simple with a focus on ease of use. The tool can be used to find cost-effective mitigation for the lack of flexibility through an investment mode. It can also consider transmission limits, other energy sectors, as well as flexibility from demand response and energy storages. After running multiple scenarios in parallel, it creates a summary of results and several sheets and figures representing the detailed results (<https://www.irena.org/energytransition/Energy-System-Models-and-Data/IRENA-FlexTool>).

The EU project OSMOSE aims for a two-step process to consider real market operation in the flexibility assessment. First, an optimal mix of flexibility can be studied using a “perfect competition” balance by considering all relevant technical constraints and associated costs (technology, potentials, “natural” loads ... ) and maximizing the social welfare of the considered zone. This assessment will show the highest gain possible, which will be used as a reference. A second step would be the introduction of forecast uncertainty, market players (and their strategies), market rules, etc. These imperfections will yield outcomes with lower social welfare than that of the perfect competition approach, but being able to compare this reference enables the system and market designer to determine the main fields of improvement. At this stage, the way the added value is shared will also come into play, which is an essential criterion to identify individual stakes and efficiently promote the needed adaptations of rules (OSMOSE D2.2, 2019).

The ongoing energy transition is affecting how much flexibility is required but also who should provide it: Some existing solutions are being phased out, whereas new solutions’ entire business models are based on providing flexibility (e.g., storage or demand response). Heggarty et al. (2019 and 2020) propose a pair of novel tools to quantify who is providing flexibility: the flexibility solution modulation stack and the flexibility solution contribution distribution. These frequency spectrum analysis-based tools separately quantify the flexibility provision on the annual, weekly, and daily timescales (Figure 74 and Figure 75). The tools are applied to both historical and prospective power systems in several geographic locations with contrasting characteristics. The proposed tools are of particular value to capacity expansion planners, allowing them to quantify changes in flexibility provision as new solutions are introduced or as carbon taxes, generation, and interconnector capacities evolve.

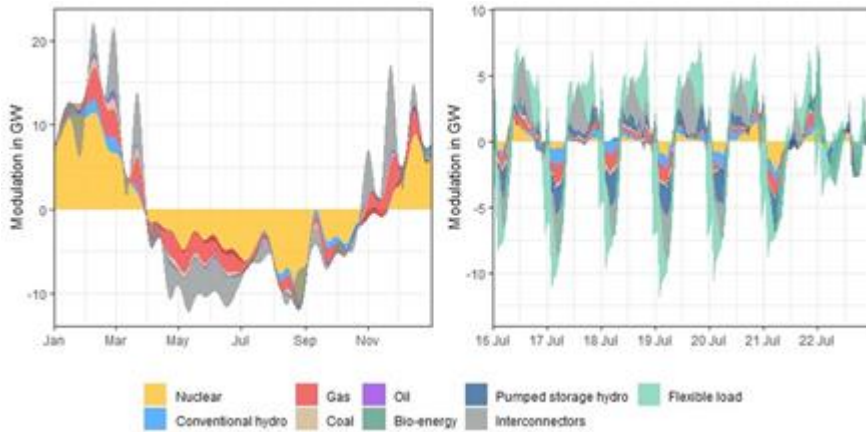

Figure 74. Who currently provides flexibility? Annual (left) and daily (right) flexibility solution modulation stacks on the power system in France in 2018. Flexible generation modulations express to what extent a technology generates more or less than on average: If a flexibility source's ribbon is above that of the previous flexibility source ribbon, this generator's output is above its average annual value. Conversely, if it is under, its output is below its average annual value (Source: Heggarty et al., 2019).

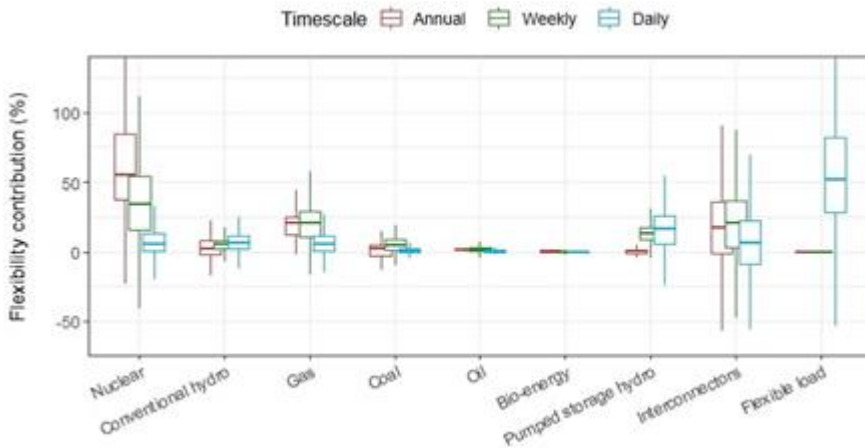

Figure 75. How do solutions currently contribute to flexibility? Flexibility solution contribution distributions on annual, weekly, and daily timescales on the power system in France in 2018 (Source: Heggarty et al., 2019)

In Denmark, the system operator Energinet aims for the market to contribute to offer solutions to increase flexibility for longer-term flexibility needs because more situations with challenged system adequacy and related increased electricity prices are



expected after 2025 (Energinet, 2020). Energinet distinguishes between two kinds of flexibility (Orths & Hansen, 2019):

- *Operational flexibility* measures across sectors must be in place because renewable energy source and consumption are variable but the energy systems need some degree of stability. This means that the flexibility needs of one sector might be provided by another sector. Regulatory and market designs must support this.
- *Resource flexibility* is needed, meaning that a dynamic change between fuel types and resources of different sectors must be possible, depending on prices, which entails that relevant market signals must be created.

### 6.6.2 Flexibility from hydropower with storage

Reservoir hydropower and pumped storage hydropower offer great balancing capabilities, but they are naturally limited by geographic and topological conditions.

The large hydro reservoirs in the Nordic area provide an interesting flexibility resource in a European context: using them as “green batteries” for variable wind and solar power. Several studies have been carried out based on power market simulations to study the use of Norwegian hydropower as a balancing resource for Europe using the potential capacity increase as the basis. The main technical barrier for using Norwegian hydropower as a green battery lies in the limited power capacity of the cables and generators, not the reservoir storage capacity itself (Jaehnert et al., 2015; Graabak et al., 2017). Figure 76 shows the small variations in hydro reservoir levels with increased hydropower capacity.

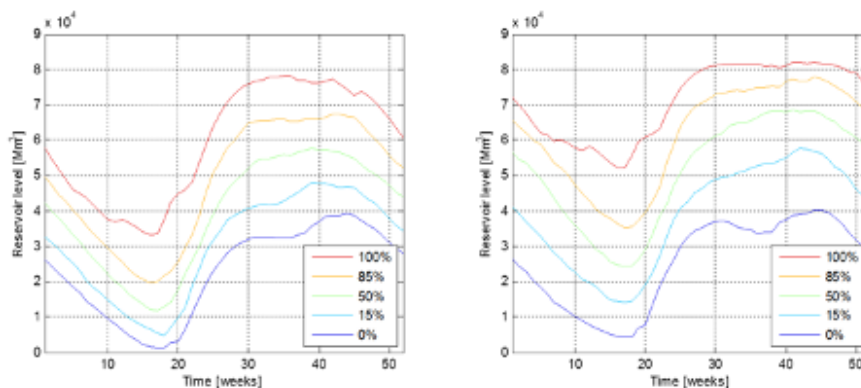

Figure 76. Aggregated simulated weekly reservoir levels for Norwegian hydropower for 2020 (left) and 2030 (right). In the 2030 simulation, an additional 11 GW of generator capacity and 5 GW of pumping capacity + North Sea interconnectors are added to the system to provide balancing capability for the European variable renewable energy sources. Source: Jaehnert, Korpås, Doorman (SINTEF/NTNU).

It is important to have models that reflect the balancing possibilities in a realistic way. For example, in Sweden and Norway, there are more than 600 hydropower plants, and the flexibility for balancing is very high because the Nordic power system has a storage capacity of approximately 120 TWh. But there are also limitations in how the hydro resource is used, with several power plants along the same river not all having a large reservoir for storing the water. Hydropower plants per price/balancing area are often aggregated to simplify the models for simulating larger areas. With a more volatile use of this resource, more detailed models for hydropower are needed to capture the limitations of flexibility (Blom et al., 2020). In Norway, a model with higher hydro detail and better representation of short-term variations and flexibility shows a clear impact on the hydropower pumping usage in scenarios with high shares of wind and solar (Graabak et al., 2019); see Figure 77.

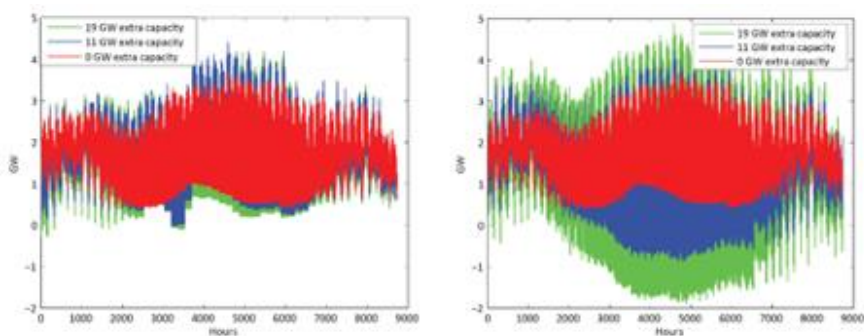

Figure 77. Aggregated simulated hydropower production and pumping using the traditional power market model EMPS (left) and the new optimization model FANSI with better representation of short-term stochasticity and flexibility utilization (right). Both figures are from the simulation of a 2050 scenario with renewable energy source share in Europe and increased interconnection capacity to Norway (Source: I. Graabak et al., 2019, <http://hdl.handle.net/11250/2638897>).

NARIS quantified the benefits of hydropower flexibility (Table 2). The results are based on a comparison of the 5-minute dispatch model runs from the low-cost variable generation scenario with runs from an identical scenario with all hydropower flexibility disabled (i.e., dispatchable hydropower generators are assumed to have flat output levels for each month). U.S. and Canadian hydropower was included in the sensitivity, so results presented are aggregated for the continent (Brinkman et al., 2021).

Table 2. Benefits of hydropower flexibility as modelled for low VRE cost scenario of NARIS for year, 2050 (Source: Brinkman et al., 2021, Table 10, p.81).

Metric	Impact
Cost	Today's level of hydropower flexibility reduces annual operating costs by \$2.3 billion, which represents 3.0% of the system production costs.
Curtailement	The flexibility of hydropower to turn down in periods of curtailement and generate more in periods of need reduces curtailement from 9.9% to 9.2%. <sup>a</sup>
Generation	The reduction in curtailement leads to a reduction in generation from fossil-fueled units of 22 TWh (1.6%); this includes an increase in coal generation of 4 TWh and a decrease in gas of 26 TWh. <sup>b</sup>
Emissions	Increased flexibility reduces emissions in this scenario by 1.3%.

These values are based on a comparison of the 5-minute dispatch model runs from the Low-Cost VG scenario with runs from an identical scenario with all hydropower flexibility disabled (i.e., dispatchable hydropower generators are assumed to have flat output levels for each month). U.S. and Canadian hydropower was included in the sensitivity, so results presented are aggregated for the continent.

<sup>a</sup> Curtailement reported here is a U.S. and Canada average, because the sensitivity was done for all U.S. and Canada hydropower.

<sup>b</sup> Because the dispatch of generators is a cost optimization, increased flexibility will lead to selecting lower-cost resources (in this case, coal because of fuel costs)

Increasing pumped hydro capacity has been identified as an important flexibility measure in Italy, Spain, and Portugal. In Italy, there are currently 22 pumped storage hydropower plants (Figure 78), with a maximum generating capacity of 7.6 GW and a maximum absorbing (pumping) capacity of 6.5 GW. There are plans for year 2030 to install +3 GW of new storage capacity. Installations in southern areas for pumped storage hydropower would give the best increase to flexibility in Italy (Terna, 2018).



Figure 78. Existing pumped storage hydropower plants in Italy (Source: Terna).

In Japan, a method for scheduling pumped storage hydro in smaller power systems with a high share of renewables is proposed to solve large net load ramping issues. The maximum upward/downward net load ramps are minimized with pumped storage hydro operation based on duration curve models of net load ramps regarding operational reserve requirements. The concept is numerically verified with the typical power supply and demand-balance problem with a high share of VRE. The proposed method can be a framework that allows storage resource scheduling. Because the proposed algorithm is based on dynamic programming, the pumped storage hydro schedule and other dynamic constraints can be considered accurately (Tanabe & Yokoyama, 2019).

### 6.6.3 Flexibility from thermal power plants and power and heat sector coupling

In China, an improvement in the flexibility from thermal power plants has been conducted in the last 5 years. More than 200 GW of thermal power plants were planned to be retrofitted from 2015–2020, including condensing and combined heat-and-power plants. Most of these power plants are located in the western and northern regions and have large share of renewables. Especially when coordinated with the market mechanism, it has improved renewable accommodation, such as decreasing curtailments in the northeast power grid. Even the power plants in the eastern regions have carried out retrofits because of the increase in renewables.

In Finland, the potential role of biomass in providing flexibility was evaluated by Lindroos et al. (2021). Backbone model simulations co-optimized the biomass supply chain together with the rest of the energy system. Four biomass technology options were compared: combined heat and power, heat-only boilers, a biorefinery, and a biorefinery together with hydrogen boosting. All options reduced system-level CO<sub>2</sub> emissions, but a biorefinery without hydrogen boosting did not provide flexibility (Figure 79). Heat-only boilers had good performance and the least risk because their investment cost is relatively low.

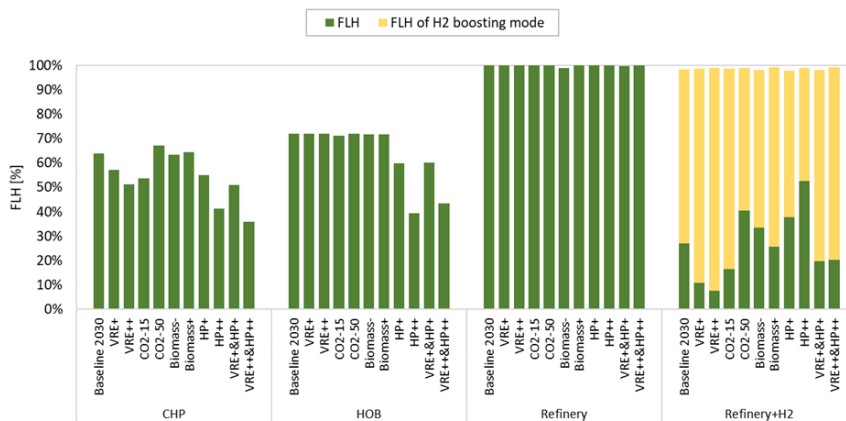

Figure 79. Full-load hours of different biomass technologies. A biorefinery without hydrogen boosting does not provide flexibility because it runs all the time. FLH: full load hours, H2: hydrogen, CHP: combined heat and power, HOB: heat only boiler. (Source: Lindroos et al., 2021)

The long-term impact of wind and solar energy as well as demand response on thermal power generation was studied by Helistö et al. (2018), who explored flexibility provision changes through ramping intensity and ramping frequency (Figure 80). Demand response affects what kind of thermal power plants are built—in principle, the increased flexibility could support more baseload power plants; however, demand response also supports wind and solar in the system, and that was more

important, resulting in decreasing baseload power plant capacity. Overall, thermal power plants were used more for larger ramps and longer-term flexibility, and demand response was used for the smaller ramps and short-term flexibility.

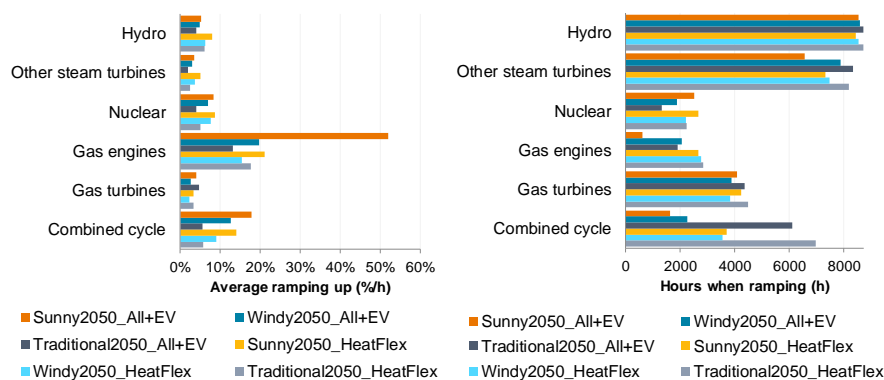

Figure 80. Ramping of conventional power plants in the northern European scenarios. Windy and sunny scenarios include more VRE (60%–67% share) than traditional (40%–43% share), and the All+EV scenarios include more demand-side flexibility than the HeatFlex scenarios (Source: <http://flexefinalreport.fi/files/The%20need%20and%20value%20of%20flexibility%20in%20North%20European%20power%20system%202050.pdf>).

#### 6.6.4 Flexibility through use of transmission and interconnectors to neighboring area

Sharing the increased balancing task with neighboring areas has shown to be an effective way of adding flexibility to power systems and helping to manage increased variability and uncertainty (see examples in Figure 36 and Figure 70).

In China, there are several regional balancing areas consisting of several provincial power grids and interconnected by cross-regional transmission lines. There is potential for these interconnected grids to share their flexibility by dispatching the transmission lines more flexibly. In 2020, the northwest power grids, which have high shares of wind and solar, had organized more than 30,000 times of power regulation among 5 provinces. This made a great contribution to mitigating wind curtailments to less than 5% in 2019–2020.

By interconnecting wind resources located in different wind regimes, the capacity value of the resource can be increased by taking advantage of diversity and moving generation across time zones, which decreases the cost of additional generation that is otherwise needed to meet resource adequacy requirements (see Section 4).

In addition to extending and reinforcing the transmission grid by conventional AC transmission, HVAC and HVDC systems can provide significant economic and reliability benefits. HVDC also provides advantages that are not available from an AC system. With the voltage source converter (VSC) technology available today, an HVDC line can provide its own reactive power requirement, eliminating the need for

external reactive power compensation at the line terminals. When the DC line interconnects two or more synchronous zones, the fast power controls of the DC terminals can also provide system stability augmentation in the event of a large AC disturbance in any of the synchronous zones. The VSC technology can also allow for the black-start of the grid after a major outage.

Macro grids (large-scale HVAC and HVDC transmission networks) can result in small increases in transmission investments but large decreases in wind/PV/storage investments as well as operating costs. For example, in ZeroByFifty (Vibrant Energy, 2020), which studies pathways to reach 100% clean energy by 2050, \$350 billion of transmission infrastructure including an HVDC macro grid, save \$1000 billion in overall system costs (fixed and variable generation, transmission, hydrogen, and distribution). In the United States, nationally optimized and coordinated transmission demonstrates great savings over locally planned transmission. Brown & Botterud (2020) examine increasing levels of optimization and coordination of transmission planning from a state-by-state approach, to regional approaches, to a national approach. As the geographic size of the optimization and coordination increases, the overall system costs decline. The system cost of energy for the national approach is 46% cheaper than the state-by-state approach. Despite small increases in transmission costs, transmission investments remain less than 10% of bulk power system costs both in ZeroByFifty (Brown & Botterud, 2020) and in the Seams study (NREL, 2020).

### **6.6.5 Flexibility from demand-side measures**

In China, demand response and electric vehicles are seen as important new flexibilities to use, and they are considered in system expansion planning for scenarios with high shares of wind and solar. Jiangsu province has already established a capacity of demand-side response of more than a GW.

The response by residential or small-office customers to market price signals has not resulted in any larger-scale demand response so far. In France, the system operator RTE found that a large part of the demand response value of residential load can be captured by well-designed “static” peak/off-peak tariffs sent to households by smart meters (such as the ones already in effect in the country). So far, the installation of “energy boxes” driven by real-time signals is worth its price for only a few hundred thousand power-hungry homes in France (RTE, 2017).

Further digitalization enabling active consumers and prosumers could change the picture. Demand response has a large potential to add to the flexibility of power systems. Aggregators are emerging and offering services by aggregating a large number of smaller loads (Perroy et al. 2020). Retail service companies could offer differentiated services based on distinct levels of guaranteed reliability (Chao, 2012).

Electrolyzers’ ability to vary their level of power consumption in a matter of seconds paves the way for them to play an increasing role in the balancing and ancillary services markets in the future. They can also provide long-term flexibility (RTE, 2020). When installed in an area in need of voltage control or congestion

management, electrolyzers could also be deployed for these purposes. Electrolyzers can also improve network congestion, local voltage stability, and rotor angle stability (as observed in simulations of a weaker test system) (TSO2020, 2020).

In the EU RealValue project (2018), smart electric thermal storage space and water-heating appliances were installed in 750 properties across Ireland, Germany, and Latvia. The impact of controllable electrical heating to provide demand shaping and demand-side management on the low-voltage network was studied with the combination of appliances acting as a virtual power plant. The main objectives were to schedule heating loads (time shifting) to cope with increasing feeder-level (and system-level) loading conditions, to reduce peak demand requirements, and to offer flexibility (frequency response) services to the power system while not impacting user comfort levels or increasing (heating storage) charging costs. System-level studies, with the technology rolled out at scale, showed that coordinated scheduling and control of the heating loads could reduce renewables (wind) curtailment and power plant cycling, particularly for Ireland and Germany, where renewable generation capacity was comparatively high and pumped/reservoir hydropower and interconnector capacity were comparatively low.

Power-to-ammonia offers a cost-effective form of long-term energy storage that will be highly beneficial for a power system relying heavily on variable power generation. Ikäheimo et al. (2018) analyzed the impact of power-to-ammonia on cost-effective decarbonization. With the CO<sub>2</sub> price at 80 €/t, the system had remaining fossil fuels in the least-cost solution. At a higher level (250 €/t), fossil fuels were fully replaced while the impact on the total system costs was not large. The production cost of ammonia (NH<sub>3</sub>) was not significantly higher than world market prices that have been encountered in recent years; thus, renewable NH<sub>3</sub> could be a viable alternative for the fertilizer sector, enabling further decarbonization within the industrial sector.

For Germany, the effect of high demand-side electrification rates on the transmission grid and the electricity supply side was assessed. An increase in the electricity demand from approximately 500 TWh to approximately 760 TWh leads to heightened stress for the transmission grid and therefore more curtailment. For the scenario with a 61% share of renewables, the integration of 19 TWh of flexible power-to-heat in district heating networks reduces the market-driven curtailment of renewable feed-in, highlighting the value of flexible electrical loads for the integration of VRE sources (Guminski et al., 2018)

#### **6.6.6 Flexibility from storage**

Large-scale energy storage represents one potential flexibility source that can provide flexibility and a range of ancillary (system) services across multiple timescales. The cost of other than hydropower storage has been too high for power system applications; however, the costs are continually decreasing, and as the share of variable renewables increases, the value of flexibility is also increasing.

The marginal value of energy storage falls as installed (storage) capacities increase because the balancing provided by previously installed storage plant



reduces opportunities for further cost savings. As the share of variable renewables increases, system flexibility increases in importance, so market mechanisms must incentivize and allow the full value of each resource's flexibility to be accessed. In general, the greater the number of services provided by a storage plant, the greater its value to the system; however, depending on the wind and solar share, alternative strategies might be viable, particularly when imperfect dispatches that reflect wind and load uncertainty and inefficient market signals are considered (O'Dwyer et al., 2017). For example, the provision of contingency reserve is particularly valuable at low to moderate wind shares, whereas at higher wind shares, providing flexibility reserve becomes essential (both in terms of profitability and system costs) because the requirement for such reserve increases and the number of conventional plants typically online and available for reserve provision decreases.

Inefficient market structures and renewable generation uncertainty, etc., can result in suboptimal storage plant operation, which has subsequent impacts on long-term plant profitability. To improve the efficiency of storage plant dispatches at high variable renewable shares, changes in operational practices are essential. Storage dispatch algorithms need to evolve to handle such uncertainty, as well as the increased volatility of energy and ancillary services prices. Look-ahead periods are required, with typical end-of-day storage-level targets inadequate at high wind shares. Ideally, the storage plant operating mode (charging, motoring<sup>4</sup>, discharging) should be optimized closer to real time, and the storage plant should be adequately rewarded for providing subhourly (in addition to hourly) flexibility. For a storage plant to generate efficient schedules, access to relevant information that could influence prices is essential, including wind and load forecasts and the status of larger plants. To achieve profit maximization, algorithms must capture price uncertainty in both energy and reserve products as well as reserve deployment volumes. Methodologies are also required that can forecast the real-time use of committed reserves because this can impact not only storage levels but also profitability because participants in reserve markets can be paid both for reserve availability and deployment.

A case study of the European power system in 2050 by Korpås & Botterud (2020) shows that EES can trigger substantial new VRE investments in the market equilibrium and thus have an important role in reducing CO<sub>2</sub> emissions from power systems operated under a competitive market regime. On the other hand, the results also indicate that EES makes very little impact on average electricity prices in the long term. How a marginal economic system benefit will impact the willingness to invest in merchant EES in electricity markets dominated by VRE is an important topic for further analyses.

The system operator is responsible for real-time balancing, and hence they can make informed decisions about real-time usage while also considering future system needs without severely constraining the capacity of a storage plant to meet those real-time balancing requirements; however, there is an ongoing debate

---

<sup>4</sup> In motoring mode, the plant is online and able to quickly respond.

surrounding the ownership of storage plant assets (IEA-RETD, 2016), notably in relation to deferring network investments, which can lead to future conflicts of interest for a system operator when attempting to balance requirements for traditional reserve and (new) flexibility ramping products.

In Italy, storage has been tested to provide frequency support by the system operator Terna on the islands of Sicily and Sardinia. A 40-MW “power-intensive” storage system installation program (e.g., energy/power ratio between 0,5 and 4 hours using SoNick (sodium-nickel) and Li-ion (lithium-ion) technology batteries) is exploiting the potential offered by the rapid response times of storage systems to increase the operating security margins of high-voltage grids. Congestion relief and active power balancing service are used to set a specific active power profile to Electrochemical Energy Storage Systems EESS (either a single device or equivalent aggregated) through an XML file or via a manual set point. As long as this service is activated, other activated power regulations (frequency support services, such as FCR, and FRR frequency restoration reserve) shall perform following this active power profile.

Hydrogen as a storage medium for renewable energy has received increased interest in recent years as more attention is given to balancing and flexibility challenges while moving toward 2050. In addition to being used as electric energy storage, hydrogen can be a viable energy carrier for transport applications and other uses. In Norway, several electricity-hydrogen integration studies were conducted with the aim to increase renewable energy penetration in power systems while providing clean hydrogen fuel for transport (<https://www.sintef.no/projectweb/hyper/>). Flexible hydrogen production could increase the amount of wind power installed in northern Norway and reduce the need for grid reinforcements (Bødal & Korpås, 2017). By adding a large-scale hydrogen production and liquification facility, as shown in Figure 81, optimal wind power capacity in the region increased from 300 MW to 650 MW. This corresponds to increasing the wind power penetration from approximately 85% to 185% of the original maximum load. Extending the analysis to include the co-optimisation of hydrogen and hydro storage enabled increasing wind penetration even further and reducing the feedstock cost of hydrogen to less than 2 €/kg in the Nordpool NO4 market area (Bødal & Korpås, 2020).

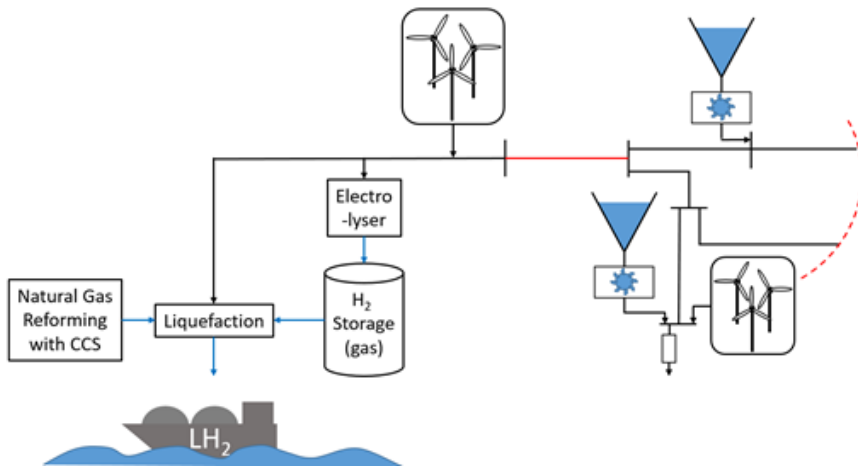

Figure 81. Illustration of a regional power system with production of hydrogen from wind and hydropower in a constrained transmission grid (red lines). CCS: carbon capture and storage, H<sub>2</sub>: hydrogen, LH<sub>2</sub>: liquid hydrogen (Source: Bødal & Korpås, 2017).

In the United Kingdom, the role of electrolyzers in facilitating higher penetrations of wind was also shown (Strbac & Pudjianto, 2021). Even when assuming that the costs of hydrogen production from renewables via electrolyzers (green hydrogen) will remain higher than the hydrogen production cost from methane-reforming processes with carbon capture and storage, there would be significant benefits for having electrolyzers in the hydrogen production portfolio to enable more wind generation to be integrated at lower costs. Hydrogen demand could significantly reduce curtailment and increase the amount of wind generation deployed.

Long-duration energy storage could also enhance the security of the system to deal with extreme weather events (see Section 4.2.1). The storage capacity becomes an important factor to deal with prolonged low or high wind periods, and this should be optimized alongside the storage power rating to maximize its system value. Hydropower with reservoirs or pumped hydro are used as longer-term storage. Hydrogen storage could also be an alternative (Pudjianto et al., 2021). The amount of hydrogen that needs to be stored is calculated as a function of the number of weeks with low wind output - time series analysis for wind only in the Great Britain system. The range (min–max) of wind energy that needs to be compensated if such event (prolonged low wind output) occurs for 241 TWh/a wind is shown in Figure 82 (Strbac et al., 2018; Strbac et al., 2020).

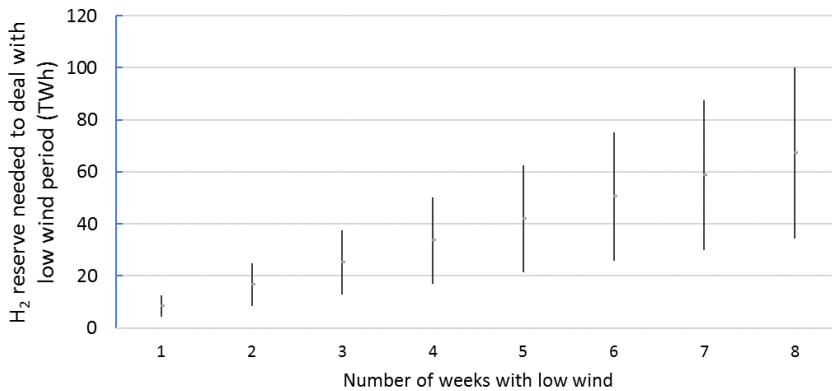

Figure 82. Long-duration storage needed to cover longer wind calms for 241 TWh/a wind energy in Great Britain (Source: Strbac et al., 2018).

### 6.6.7 Comparing flexibility options

For the northern European power system, a 2030 scenario with approximately 40% renewable energy penetration with different flexibility options showed that pumped hydro and batteries complements each other by taking different roles: Batteries provide short-term balancing over 1 to some hours, whereas pumped hydro counteracts the longer periods with prevailing low or high net load. This is because the cost of batteries is mainly driven by the kWh capacity, whereas the hydro storage costs are driven by the kW costs (cables + reversible pumps). Batteries would reduce the need for peaker power plants (open-cycle gas turbines), whereas pumped hydro reduces the need for combined-cycle gas turbines (Askeland et al., 2016).

In the United States, a comparison of costs for transmission and storage for the MISO RIIA shows an optimum at 0.5 GW of storage plus transmission for 40% wind and solar penetration in the Eastern Interconnection (Figure 83). Interestingly, the transmission-only solution is only marginally more expensive. The storage-only solution, on the other hand, is far more expensive and builds 16 GW of storage to ensure that the system can balance during the entire year.

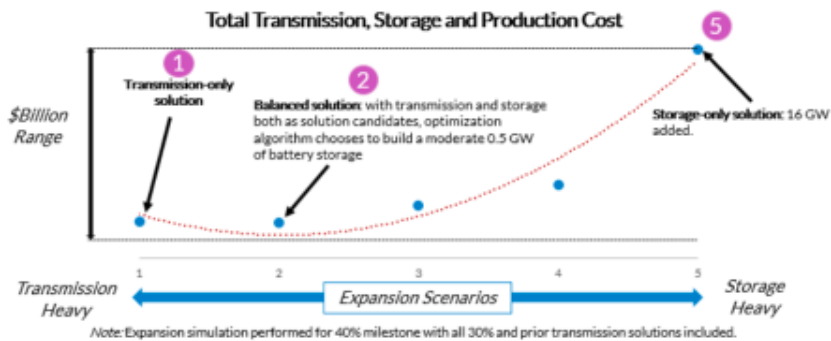

Figure 83. Comparison of transmission-only solutions, storage-only solutions, and combined transmission-and-storage solutions for 40% wind and solar penetration in the Eastern Interconnection of the United States (Source: MISO, 2021).

Brown and Botterud (2021) find that to meet 100% clean electricity, the battery storage capacity necessary in the national approach is 23% of that in the state-by-state approach. The national approach enables a macro grid to take advantage of the diversity of wind, solar, load, and storage resources to reduce the amount of battery storage necessary.

Strategic investment planning under uncertainty and comparing transmission and storage assets by considering the risk of stranded assets would give another picture because storage holds option value, allowing for deferring or displacing network reinforcement. This uncertainty is around timing (When will the connections happen?), location (At which countries?), and magnitude (How much will the growth be?), and renders network planning particularly challenging. A case study (Most et al., 2020; Plan4res) models the electric power system operation and investment across 33 countries in Europe over a 40-year long horizon, from 2020 until 2060, for the optimal investment decisions under uncertainty. In this optimization, there are many locations in Europe where storage sees a cost-benefit. The timing, location, and magnitude of investments in energy storage and in conventional reinforcement show the value of flexibility (option value) of investing in electric energy storage and is associated with the economic net benefit that this technology brings to the system planning under uncertainty.

The comparison of flexibility options for the northern European system showed that the power-to-heat options and increasing transmission capacity provide the best value for shares of approximately 40% wind-dominated variable generation, Figure 84 (Kiviluoma et al. 2017).

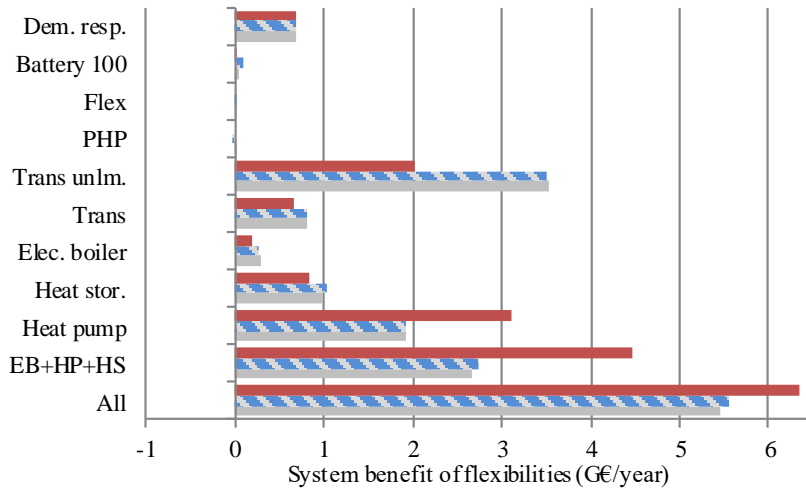

Figure 84. Case of northern Europe with 40%–50% wind. Power system operational costs for 1 year, difference between with/without flexibility option. The model detail makes a difference in capturing the value of flexibility (red: investment model only, striped: investment model and operational model using linear programming LP, grey: investment model and operational model using mixed integer programming MIP) (Source: Kiviluoma et al., 2017).

## 7. Pushing the limits: Toward 100% shares of renewables

A power system operating at 100% non-synchronous generation has not yet been seen nor proved to work. There are solutions to make it work technically, and this is an evolving research topic, with interesting experience emerging from smaller island systems.

Exploring possible operational practices with high VIBRES shares, including power system stability, has only started (MIGRATE project <https://www.h2020-migrate.eu/>). A 100% VIBRES power system would differ significantly from a traditional power system in both design and operation. Due to the high investment costs and long lifetimes of electric power equipment, for most systems, the transition to a (nearly) 100% VIBRES system is expected to happen gradually during the next couple of decades. A system split as a result of some disturbance, however, could result in a large region of an existing system potentially operating with an ultrahigh VIBRES share for an extended period of time (hours) today. Further, even at today's modest annual energy shares of VIBRES, the variable nature of renewable sources implies periods of high VIBRES power shares for hours or days, when 50% of demand is supplied with VIBRES (as shown in the introduction; see Figure 4) (Hodge et al., 2020).

Simulation model tools also need to be developed to study the future system operation in detail and to determine the resilience needed for system operators to fully trust non-synchronous sources for stability support.

The energy transition to low-carbon and zero-carbon energy systems will involve smart sector coupling. Future power to X options—including electrifying heat, transport, and industrial processes—all offer potential solutions for supporting stability and offer longer-term flexibility to support resource adequacy.

### 7.1 Experience of near 100% inverter-based power systems

One utility that has achieved success with very high instantaneous shares of IBRs and regularly runs at 100% renewable energy is the Kauai Island Utility Cooperative (KIUC), the utility for the Island of Kauai in Hawaii, United States. Although KIUC regularly operates using 100% renewable energy resources during the day, it has achieved almost 9 straight hours of 100% renewables operation. It often operates at up to 80%–85% PV penetration. On an annual average basis, approximately 65% of the energy comes from renewables.

KIUC is a small cooperative utility with a peak demand of approximately 80 MW and a minimum demand of approximately 35 MW. It has zero interconnections to other islands. Due to endangered seabirds and a low wind resource, the utility has focused on a PV-dominant system in its plans to reach 100% renewables by 2045. It has ample quick-start diesel reciprocating engines to provide fast reserves, but although these can start up in minutes, they are not fast enough to mitigate cloud events (on the order of seconds) on this small island; therefore, the utility decided

to back up the PV plants with battery storage. In 2017, it pioneered the first power purchase agreements for PV/battery hybrids, and today it has the following systems: 13 MW of PV with 4 hours of battery storage (52 MWh); 20 MW of PV with 5 hours of battery storage (100 MWh); and 14 MW of PV with 5 hours of battery storage (70 MWh). For their spinning contingency reserves for these hybrid plants, the battery storage in the hybrids is sufficient. The stand-alone PV plants hold 50% of the real-time output as spinning contingency reserve.

To manage the high instantaneous penetrations of IBRs, the utility retrofitted an aeroderivative gas turbine to be able to operate in synchronous condenser mode so that it does not provide energy, only inertia and system strength.

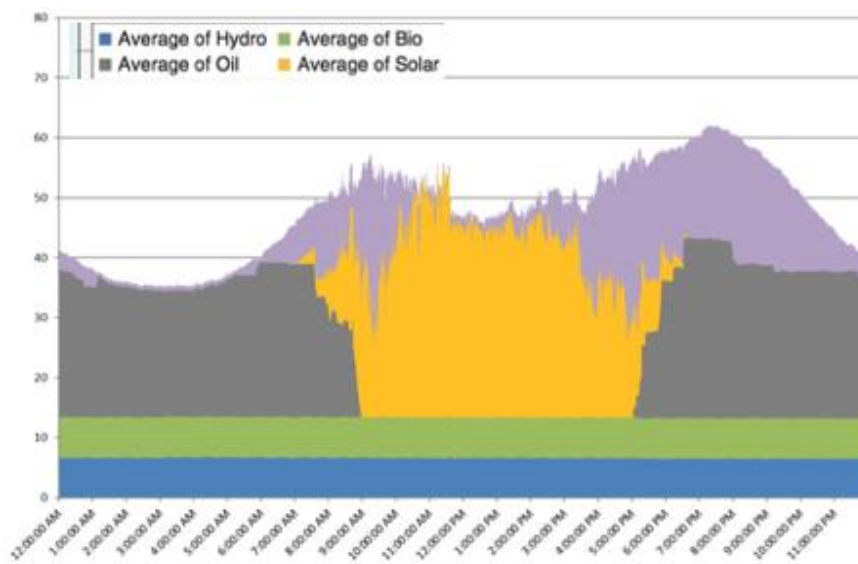

Figure 85. KIUC system dispatch on March 14, 2020 with 8 hours of 100% renewables operation. Purple shows PV/battery hybrid output (Source: Brad Rockwell, KIUC).

In Denmark, system operation without large power plants online has become more frequent since the first event in 2015 (reported in Holttinen et al., 2019). The Danish power system consists of two parts, each of which is a part of a larger synchronous system. When all large power plants are offline, the essential reliability services are sourced from HVDC links and smaller power plants.

## 7.2 Challenges for near 100% renewables system operation

Assessing the technical feasibility of scenarios in which the power system would be based on very high shares of renewables, IEA-RTE (2021) found four sets of strict conditions that would need to be met in a large power system such as that of France:



- There is general scientific consensus that technological solutions to maintain power system strength—and hence system stability—without conventional generation exist in several cases. Specific difficulties are expected in the case of a system with a significant share of distributed solar PV. Further assessments of the impacts of distributed PV on the distribution network are needed as well as on their implications for electricity security.
- System adequacy—i.e., the ability of a power system to cope with load at all times—can be ensured even in a system mainly based on variable renewables such as wind and solar PV when substantial sources of flexibility are available, including demand response, large-scale storage, peak generation units, and well-developed transmission networks and interconnections. The maturity, availability, and cost of these flexibility sources need to be considered.
- The sizing of operational reserves and the regulatory framework for balancing responsibilities and procurements would need to be substantially revised, and the forecasting methods for variable renewables would need to be continually improved.
- Substantial grid development efforts would be necessary beyond 2030 at both the transmission and distribution levels. This requires strong proactive steps and public engagement in long-term planning, assessing costs, and working with citizens on social acceptance. These efforts can nonetheless be partly integrated in renewals of ageing network assets.

ENTSO-E et al (2020) list challenges that need more R&D and demonstrations, regarding use of new grid forming technology in the power system. Where and when will the grid forming services need to be available? If installed deeply embedded (medium and low voltages), would grid forming be effective for all the challenges? Does a mix of synchronous condensers (SCs) and IBRs prove an economic solution to adding system strength? Should these be large central units or smaller decentralised units? How economic and practical is the use of large decommissioned generators as SCs?

IBR-dominated systems are fundamentally different in many ways, and the differences need to be reflected in the design, analysis, operations, and planning of systems. There is a vast difference between a 75% penetration of VRE supported by some synchronous generators and synchronous compensators and a 100% VRE all-IBR system. There is a need for fundamental research to establish an evidence base for the best way forward. The changes are so profound that a fundamental rethinking of power systems is required. Incremental tweaking and artificially forcing IBRs to look like synchronous machines is a short-term strategy that is limited and does not leverage the true potential of IBRs. IBRs can be highly flexible and controllable, with independent control over real and reactive current, and they have an ability to shape the equipment's response to various grid conditions. Because of this, there could be opportunities to make IBRs behave better than synchronous machines in some respects; however, the control algorithms that dictate the

response of IBRs to grid conditions are not heterogeneous across various inverter designs and manufacturers, and these can interact at both a local and system-wide level and with other elements in the power system, such as HVDC transmission terminals. This dramatically complicates the analysis of IBRs in the power system and could lead to stability challenges. Also, the challenges are compounded because currently most inverters do not provide certain services such as inertia response and high fault current, both of which contribute to maintaining stability (ESIG, 2019; G-PST, 2021).

One of the biggest challenges is how to manage the bulk power system when it is at times dominated by IBRs and at other times (only hours apart) dominated by synchronous machines—and all other possible combinations in between, both spatially and temporarily.

This has implications for tools and methods, including control room tools. This also means that the definition of needed system services will change; the provision of those services must come from a broad spectrum of resources.

Another challenge is assessing resource adequacy for weather-dominated, energy-constrained resources in a cost-efficient way (ESIG, 2021b).

### **7.3 Study methodologies for near 100% renewables system operation**

There is need for the further development of the models and methods of study, and some key issues and recommendations can be identified across the challenges for planning, operation, and system stability (Holtinen et al., 2020):

- **Modelling complexity:** There will be an increased computational burden because more VIBRES details need to be captured—and more data are needed to capture higher resolutions (both time resolution and distributed resources) and larger areas, with extended time series to capture weather-dependent events.
- **Larger areas:** The entire synchronous system is relevant for stability studies. Sharing resources for balancing and adequacy purposes with neighboring regions will be more beneficial.
- **New technologies:** All tools need to be modified to enable new types of (flexible) demand and storage while facilitating further links through energy system coupling.
- **Modelling integration:** There will be increased importance in integrated planning and operation methodologies, tools, and data. Operational and planning timescales/models need greater overlap. Flexibility needs and plant capabilities must be incorporated into adequacy methods, and stability concerns must be considered for network expansion planning and operating future grids.

- **Cost versus risk:** The reliability interface needs to be revisited, with the evolution of flexibility and price-responsive loads to ensure that high-cost increases are not imposed when modified reliability targets could yield acceptable results.

Looking forward, new paradigms for 100% IBR-dominated, asynchronous power system operation can be found. This would profoundly impact the tools and methods used, especially for stability.

### 7.3.1 Operational models: Unit commitment and Economic Dispatch

The introduction of **subhourly unit commitment** and economic dispatch approaches can be helpful in certain regions, given that it can capture the increase in short-term ramping requirements; however, this will be achieved at an increased computational cost, which is clearly not desirable. Whether the benefits outweigh the disadvantages will depend on the size of the system, and the composition and dispersion of the renewable energy resources, whether they are predominantly wind and/or solar based. Comparisons have been made between the all-island system of Ireland and a combined Germany-Austria system (Danti et al., 2018). As expected, hourly resolution modelling underestimates the subhourly (15-minute) ramping requirements, although this effect was greater in Ireland, presumably due to the greater smoothing effect resulting from the greater geographic dispersion in the Germany-Austria case. It tends to follow that smaller and less geographically diverse power systems benefit more from subhourly operation than larger, more diverse systems. Further, systems with higher levels of interconnection or other sources of short-term flexibility, such as demand response or energy storage, can more easily accommodate short-term variability without resorting to (renewables) curtailment or redispatch, compared to systems with limited interconnection, which reinforces the value of subhourly modelling in smaller systems with limited interconnection. The benefits of subhourly scheduling were seen to be similar for wind-dominated and solar-dominated systems in terms of identifying significant ramp events, although such conclusions can be sensitive to the definition of a significant ramp event, e.g., based on absolute size and duration of ramp or measured relative to the instantaneous system demand. Additionally, variable renewable uncertainty as well as variability can contribute to a system's hourly and subhourly flexibility requirements.

To address the low-inertia problem, a **commitment-and-dispatch ROCOF (future) constraint** within a unit commitment algorithm has been proposed, which explicitly considers the commitment status and power output of synchronous resources as well as the (generator) contingency set (Daly et al., 2019). Comparison is made with an inertial floor (current) approach based on the worst-case conditions. The future (ROCOF) approach tends to reduce the number of online (large) generating units compared to the current (inertia floor) approach, as shown in Figure 86 for a future Ireland and Northern Ireland system, with consequent reductions in operational cost and CO<sub>2</sub> emissions also achieved.

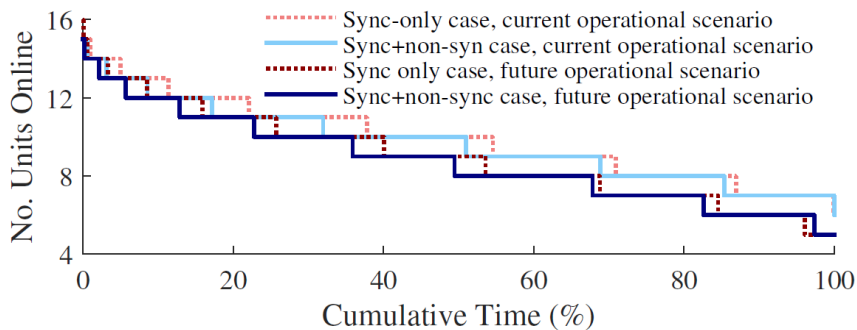

Figure 86. Simulation results from the island system of Ireland, showing how a future operational scenario catching the RoCoF constraint will result in less synchronous units online (Source: Daly et al., 2019).

### 7.3.2 Planning timescale: capacity expansion

**Modelling investment timescales** with variable generation and sector integration is computationally challenging. It is important to know which details need to be included because there are several temporal and technical details that potentially have a high impact on the optimal investments seen by the model. A review of variable generation integration studies (Helistö et al., 2019) showed that the temporal resolution and coverage needs to be high enough to determine the optimal generation portfolio—for example, using only few representative days is not sufficient. Considering system stability aspects and power plant operational limits, such as startup and shutdown characteristics, also proved to be important to get a more optimal generation portfolio and a more realistic estimation of system costs; however, they appeared to be less significant than the temporal representation.

Comparing **representative day selections** (Helistö et al., 2020) showed that even 3 representative weeks is not necessarily enough in a multi-region generation expansion planning model. Four weeks gave more reliable results, and after 7 weeks, the total cost results started to steadily converge. Several methods exist for selecting the representative weeks from time series, and random sampling with enough iterations proved to be easy to implement, fast to solve, and lead to good generation expansion planning results. The results also highlighted the importance of including a peak net load situation in the model, as well as estimating its position in the original time series and its weight in relation to other model time steps. This is challenging because the position can change when the model invests in more variable generation, the position is not necessarily the same in all regions, and the weight should be based on probabilistic assumptions about its frequency in the long term.

**Temporal and operational representations** can have different benefits and weaknesses in different systems (Helistö et al., 2021). For example, some strategies can better capture long-term storage needs, and some are more suitable for

short-term storage modelling. Likewise, solar-dominated and wind-dominated systems have different temporal characteristics and consequently also different methodological requirements. The interactions between energy sectors and the operational limits of the technologies for sector coupling should also be correctly modelled because they significantly impact the value of different technologies and their flexibility. Testing machinery will be useful for determining the most suitable model structure for each system and purpose.

### **7.3.3 Dynamics: Stability**

Dynamic stability problems resulting from control interactions among inverter-based resources (IBRs) are a major concern toward maintaining the reliability of a power system in transition to high shares of renewable generation, reaching up to 100% (Shah et al., 2021a). Most stability events involving IBRs over the past decade were local in nature (see Section 5.2.1), however, dynamic stability events involving wider network and numerous IBRs are becoming more common because of ever increasing levels of IBRs and reduction in the grid stiffness due to the displacement of synchronous generators. Recent electromagnetic transient (EMT) simulation studies further demonstrate increased risks of dynamic stability problems in power systems with 100% IBRs (Electranix, 2021); these problems manifest as system-wide under-damped or sustained oscillations that might lead to disruptions and equipment damage. One important question that arises whenever system-wide oscillations involving tens to hundreds of IBRs are observed in the field or in EMT simulations is what is the role and participation of different IBRs in the observed oscillation modes, or to put it simply, “which IBRs are causing oscillations?”. The answer to this question is important for designing mitigation methods including curtailment or removal of IBRs that contribute negatively to system damping, tuning of IBR control parameters, selection of IBR control modes such as reactive power control versus voltage control, and the use of grid-forming inverters for system stability. Existing stability analysis tools for bulk power systems, however, are not capable of answering this question because they depend on publicly available equation-based models of generators; such models are not available for IBRs because vendors do not disclose internal details of IBRs so as to not disclose business sensitive information on control architecture and methods. NREL has developed an impedance scan tool to address this challenge and identify the role of different IBRs in oscillation modes observed in field or EMT simulations (Shah et al., 2021b; Shah et al., 2021c), Figure 87.

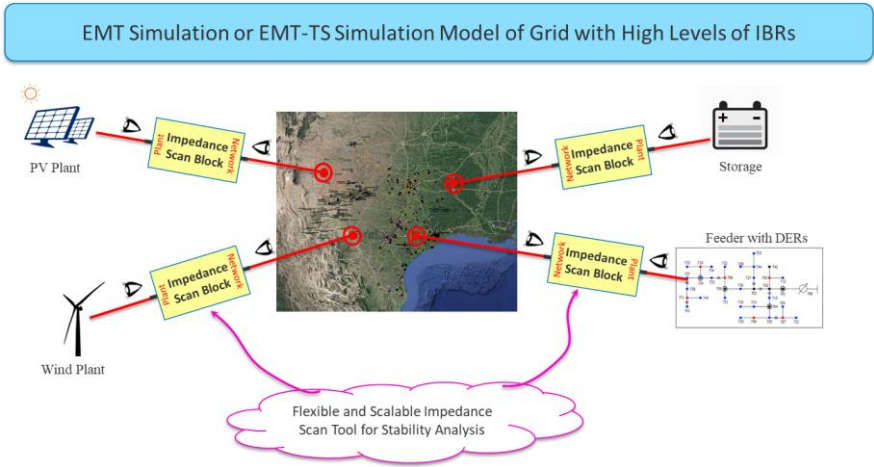

Figure 87. NREL's impedance scan tool for stability analysis of 100% IBR grids.

**The dynamic equivalent of a distribution grid** has been developed in the framework of EU-SysFlex. This tool provides a set of parameters and model architecture to the TSO, enabling the representation of distribution grid-connected assets for transient stability studies. The provision of these equivalent models is based on standardized model representation, and it does not provide parameters, distribution grid layouts, or any sensitive data/information between the DSO and TSO, Figure 88.

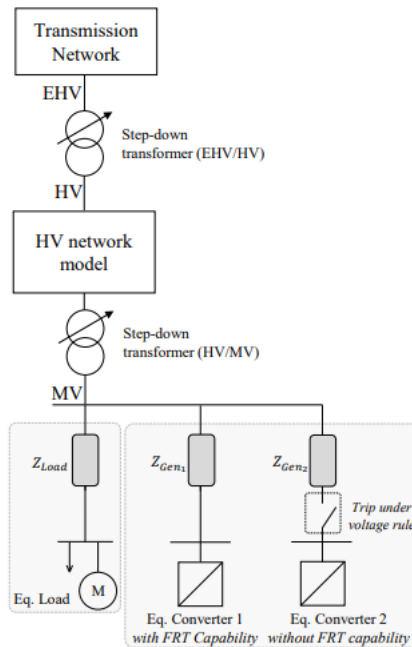

Figure 88. Dynamic equivalent model for active distribution network representation (EU-SysFlex D6.3, 2019.)

**A real-time smart digital twin** concept is proposed by CRIEPI the Central Research Institute of Electric Power Industry in Japan. It is a real-time digital reproduction of the physical situation of the power system, based on synchronized wide-area monitoring, control, and data acquisition (SCADA) to provide more real-time situational awareness to ensure the safety, reliability, and efficiency of power systems. The goal is to maintain and improve the stability of the power system and increase its resilience for early recovery from power outages by effectively using the control capabilities of renewable energy, demand response, and virtual power plants.

**Future IBR-dominated power systems:** The underlying nature of the power system is changing from one based largely on a synchronous paradigm to one based on a non-synchronous paradigm. These changes will both limit the applicability of some existing tools and methods as well as dictate the development of new tools and methods to ensure the reliability, security, and stability of the power system. Further, an increasingly variable, distributed, and IBR-based power system will also compound existing challenges to analyzing and interpreting results from existing power system models; therefore, analytic tools that help evaluate the operation of a power system with a large number of IBRs must be developed—specifically, tools to capture the interactions and impact of IBR control algorithms that can be detrimental or beneficial to the power system’s stability and performance (G-PST, 2021).

## 7.4 Studies for 100% renewable power systems

Some techno-economic studies have examined how hourly energy balance could be maintained in a 100% renewable power system. Some of these studies use unit commitment and economic dispatch to capture wind/solar energy variability/uncertainty and to investigate system and market behavior (Heard et al., 2017; Brown et al., 2018). Several studies have coupled other energy sectors, e.g., the heat sector (Ringkjøb et al., 2018; Ikäheimo et al., 2018). Often, these studies optimize investments in conversion, transmission, and the storage of energy, although the operational detail can vary greatly depending on the applied methodology (Helistö et al., 2019); however, power system stability is often overlooked as part of 100% (energy-balancing) studies, where the main focus is on hourly consumption-generation matching. No study comprehensively addresses both the long-term and short-term challenges (Holtinen et al., 2020).

Recent studies in the United States address a renewable power system (and some address a net-zero carbon, decarbonized future energy system (see the following section). A MIT (Massachusetts Institute of Technology) study used a co-optimized capacity planning and dispatch model over 7 years of hourly operation and showed that interstate coordination and transmission expansion reduce the system cost of electricity in a 100% renewable U.S. power system by 46% compared with a state-by-state approach, from 135 \$/MWh to 73 \$/MWh. Sensitivity analyses show that reductions in the cost of solar PV, wind, and lithium-ion batteries lead to the lowest electricity costs for systems in which transmission expansion is allowed, whereas cost reductions for nuclear power or long-duration energy storage lead to greater electricity cost reductions for isolated systems. The results suggest that a zero-carbon electricity system for the United States based on VRE and storage is feasible at 1-hour resolution over many years of operation, accounting for the costs and constraints of transmission and land availability, using technologies currently being deployed at the gigawatt scale. Although decarbonization of the electricity system is feasible at the level of individual states and regions, it can be accomplished at a significantly lower cost when implemented at the national level (Brown & Botterud, 2021).

In Sweden, the TSO Svenska Kraftnät has studied a future scenario with an increased electrification demand from 140 TWh/year to 179 TWh/year and where the current nuclear power is assumed to be replaced with renewable power. In the “2040-high” case, there is an assumption of 106 TWh of wind energy and 7 TWh of solar energy. The remaining power is hydro and biofuels. Significantly more transmission both within Sweden and to neighboring countries are assumed (+16 GW) as well as, e.g., flexible electric vehicles. No specific new power plants were assumed to cover peaks. An adequacy calculation included Monte Carlo simulations of 31 weather years and resulted in a need for more capacity during 0.7 hour/year as a mean value (SvK, 2018).



## 7.5 Toward carbon-neutral energy systems

The energy sector coupling with future power to X options electrifying heat, transport, and industrial processes all offer potential solutions for the short- and long-term flexibility needs of VRE-dominated power system operation. Decarbonization of the energy system implies modifying all energy sectors. Regarding the power sector, the reduction of direct CO<sub>2</sub> emissions by adding only VRE is tapering off when the power system is already low carbon (Figure 89); however, decarbonizing other energy sectors means that CO<sub>2</sub> emissions are reduced from heat, transport, and industry.

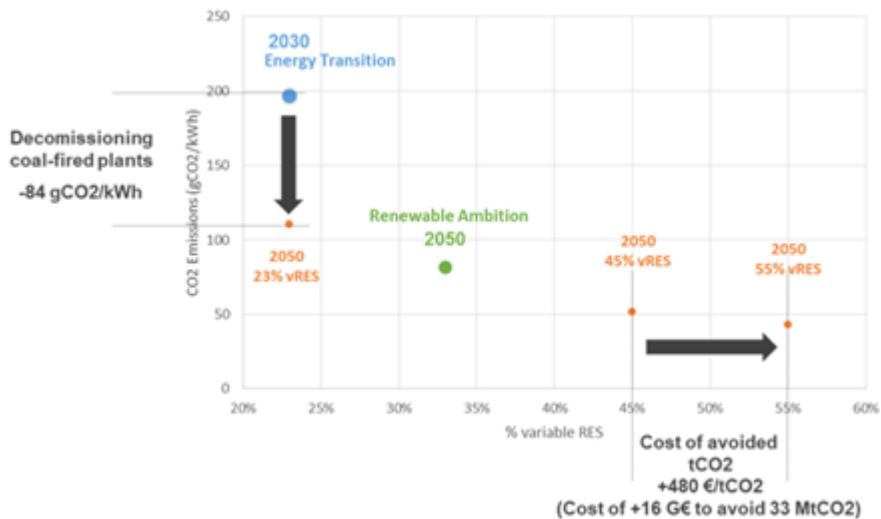

Figure 89. Direct CO<sub>2</sub> emissions per kWh depending on the VRE share in the European system (Source: EU-SysFlex D2.5, 2020)

As the ambitious targets toward net-zero carbon energy systems are announced globally, many scenarios are made for how to reach the future energy systems, both for individual jurisdictions and globally (IEA, 2021). As with 100% renewable power system studies, power system stability is overlooked, and the main focus is on hourly consumption-generation matching.

Deep decarbonization through electrification means high increases in electricity demand—approximately doubling the demand with new electrification loads despite energy-efficiency measures to reduce the current loads. In Europe, the project eXtremOS made a detailed assessment to confirm that sufficient VRE potential in Europe exists to cover a drastic increase in European electricity demand. On a national level, this is also true for most countries. Only in smaller countries with areas that have less VRE potential, such as Belgium or Luxembourg, did electricity demand exceed rated VRE potential (eXtremOS, 2021).

The EU has committed to cut greenhouse gas emission by 55% compared to 1990 by 2030, a key milestone in reaching climate neutrality in 2050. The European Commission's analysis shows that direct electrification, complemented with the indirect electrification of hard-to-abate sectors, is the most cost-effective and energy efficient way to cut energy sector emissions to net-zero by 2050. The respective EC scenarios show that more than three quarters of the final energy demand will be electrified. Electricity will directly cover 57% of final energy uses while providing another 18% indirectly through hydrogen and its derivatives. This will require the electricity system to grow to 6,800 TWh from less than 3,000 TWh today and it will require wind energy to be 50% of the EU's electricity mix with renewables representing 81%. Wind energy will become the no. 1 source of electricity in Europe shortly after 2025 and by 2030 it will provide 25% of the EU's electricity needs. The (ETIPWind, 2021) report finds that deep decarbonisation of the economy is possible and it will cost no more as a share of GDP than our energy system costs today. The energy system cost relative to GDP will be similar to 2015 levels - 10.6% of GDP. Reaching net-zero emissions in industry will require the substitution of fossil-fuel feedstocks with renewable hydrogen and derivatives in steel, cement, chemicals, and refineries. The passenger vehicles market will be fully electric by 2050. Short-distance maritime transport can technically be electrified, but investments in ports is still needed to provide robust infrastructure. For deep-sea transport, renewable-based ammonia appears one of the most promising technology along with renewable hydrogen. Heat pumps will drive the decarbonisation of heating and cooling in buildings, by almost tripling electrification rates in residential buildings. Grid investments need to double from the current €40bn a year by 2025 at the latest. By 2030 Europe needs an additional 85 GW of interconnector capacity on top of today's 50 GW. The EU will need to deploy an optimised offshore grid to deliver on its objective of 300 GW of offshore wind by 2050. Sea basin planning, speeding up permitting, and new market arrangements ensuring offshore hybrid projects are pre-conditions to having an optimised offshore grid (ETIPWind, 2021).

In the United Kingdom, the system-level value of deploying flexibility across the heat, transport, industry, and power sectors across different decarbonization scenarios shows that the coordinated operation and planning of hydrogen, gas, transport, heat, and electrify infrastructures will become increasingly important to deliver a secure energy system while meeting the carbon targets at minimum costs. The value of flexibility to the energy system as a whole is many times its value to the electricity sector alone because it allows for interactions at all levels in an integrated system, between the energy vectors, and at the different timescales, from seconds to seasons, that are required to maintain a secure system (Strbac et al., 2020; Strbac & Pudjianto, 2021).

In Denmark, the main target is to be carbon neutral in 2050, with ambitious greenhouse gas reduction target already in 2030. This requires actions across all sectors and comprises the implementation of existing measures and the development of innovative solutions (Energinet, 2018, Energinet, 2020). The measures solving flexibility and adequacy issues should also contribute to greenhouse gas reduction target by 2030, which is expected to trigger additional challenges via electrification,

the phase-out of thermal plants, and power-to-gas usage. The overall transition is causing high uncertainty that has been investigated in studies of potential pathways. One pathway identifies a number of potential developments: significant increases in the direct electrification of the heating sector, the transport sector, and industry, including the production of more renewable energy source fuels from, e.g. P2X which can replace fossil fuels. These lead to a significant increase in electricity demand from the initially expected 50 TWh in 2030 by an extra 12–20 TWh to a level of 62–70 TWh electricity demand in 2030. Offshore wind, including the energy islands, are expected to provide most of the new renewable energy needed. The results are based on detailed models of the energy system, are embedded in a representation of surrounding countries, and have been built to investigate further decarbonization and applying sector coupling (Figure 90), where cross-sectoral flexibility options can also be identified. These models represent different types of “energy plants” and are spread across the country. Energy plants can be understood as extended combined heat-and-power units with additional functionalities. These additional functionalities can be, e.g., the production of hydrogen, CO<sub>2</sub> (for some industrial processes), high-temperature heat, bio- or electro-fuels (e.g. biogas, methane), and fertilizers (e.g. ammonia), which are post-processing products from these energy plants made of hydrogen, carbon, nitrogen, etc. These modelled energy plants link various sectors and act depending on power prices. At low electricity prices (e.g., during periods of excess wind/solar power), they use electricity and biomass to produce chemical products and heat; whereas at high electricity prices, they use biomass/ biogas to produce electricity heat and a smaller amount of biofuels.

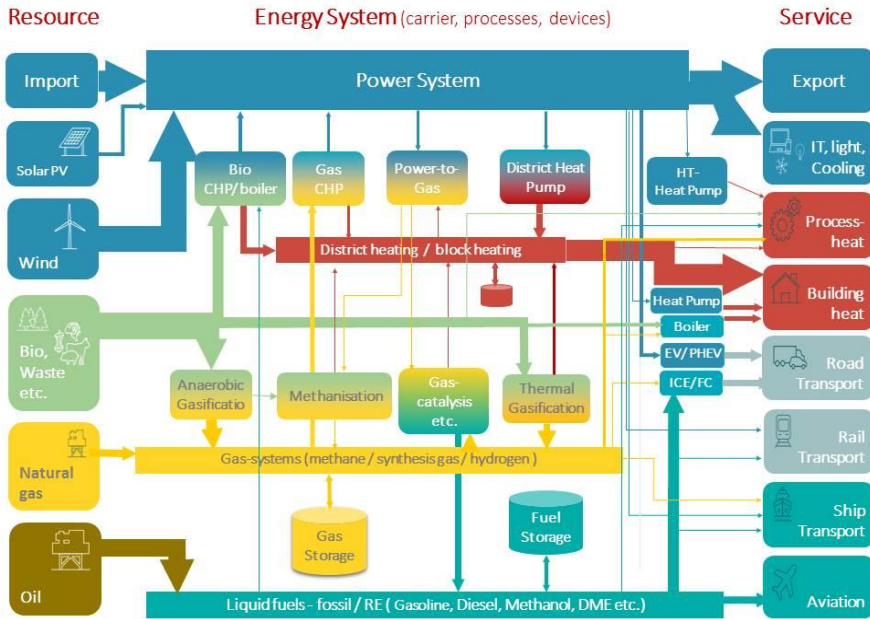

Figure 90. Energy flow in the Danish energy system for 2035 (source: Orths & Hansen, 2019).

In France, several electricity scenarios to reach carbon neutrality in 2050 are studied, either by replacing some decommissioned nuclear reactors with new ones and complementing this with higher shares of renewables to obtain a full decarbonized electricity mix or by replacing decommissioned reactors with renewables only. If the latter option is chosen, the share of renewables would reach approximately 85%–90% by 2050 and 100% by 2060.

In the United States, the *Net-Zero America* report outlines five distinct technological pathways for the United States to decarbonize its entire economy. It concludes that with a massive, nationwide effort, the United States could reach net-zero emissions of greenhouse gases by 2050 using existing technology and at costs aligned with historical spending on energy. The study's five scenarios describe—in a highly detailed, state-by-state level—the scale and pace of technology and capital mobilization needed across the country, and they highlight the implications for land use, incumbent energy industries, employment, and health. The scenarios that the new research details include a high electrification, or E+ scenario, which involves aggressively electrifying buildings and transportation, so that 100% of cars are electric by 2050. The less high electrification, or E- scenario, electrifies at a slower rate and uses more liquid and gaseous fuels for longer. Another scenario, noted as E- B+, allows much more biomass to be used in the energy system, which, unlike the other four scenarios, would require converting some land currently used for food

agriculture to grow energy crops. The E+ RE+ pathway is an all-renewables scenario and is also the most technologically restrictive. It assumes no new nuclear plants would be built, disallows belowground storage of CO<sub>2</sub>, and eliminates all fossil fuel use by 2050. It relies instead on the massive and rapid deployment of wind and solar and greater production of hydrogen to meet carbon goals. The E+ RE- scenario, in comparison, relies on limited renewables, constraining the annual construction of wind turbines and solar power plants to be no faster than the fastest rates achieved by the country in the past, but it removes other restrictions. This scenario depends more heavily on the expansion of power plants with carbon capture and nuclear power (Princeton University, 2020).

Another study, ZeroByFifty, co-optimized generation, transmission, and storage in a combined capacity expansion and production simulation model, which allowed for the expansion of an HVDC macro grid across the United States. It also co-optimized across the distribution interface to build distributed generation and storage. The study examined the role of transmission in the decarbonization of the U.S. economy by 2050. More than twice today's transmission capacity gets added to today's existing network to decarbonize the entire economy by 2050. ZeroByFifty finds that an HVDC macro grid reduces the cost of full decarbonization by \$1 trillion (Vibrant Energy, 2021).

In full decarbonization of the energy systems, the cost-effective pathway seems to include the electrification of most fossil fuel-based energy consumption; however, some liquid fuel consumption will inevitably remain for aviation, long-distance shipping, some industrial applications, and possibly as a backup energy source for the heating sector. It is therefore important to compare different pathways to produce the needed fuel without carbon emissions. Ikäheimo et al. (2019) show that biomass can be a cost-effective pathway compared to synthetic natural gas if there is a viable biomass resource. In another article, Ikäheimo et al. (2018) explore the potential of the power-to-ammonia pathway. Ammonia is already used in large quantities in the fertilizer industry, and it could be used as an energy vector as well. The article demonstrated that power-to-ammonia can already be competitive with ammonia produced from fossil fuels in the right circumstances and that ammonia can be a great source of temporal and spatial flexibility to the power system.

## **7.6 Stability of 100% variable renewable grid**

The 100% renewable studies covering larger areas, several years, and energy sectors other than electricity do not include detail of the power system to assess the feasibility of future operation including stability issues. Work is emerging to show how future IBR-dominated grids could operate. In power systems where renewables would consist mainly of wind and solar, new paradigms for asynchronous operation could also be the way forward (ESIG, 2019).

The EU project MIGRATE investigated new options for existing system services and the need for new system services in power systems based on 100% generation with converter interface (inverter-based resources IBRs) and therefore near-zero

natural inertia (MIGRATE D3.3 and D3.4, 2019). The main issue was to solve frequency stability problems due to very low inertia.

Operational rules that might be associated with a 100% converter-based grid were investigated in terms of ensuring robustness against likely disturbances. New system-level control schemes and optimization methods were studied to implement grid-forming capabilities on inverter-based devices. Grid-forming allows the power system to overcome the very first milliseconds after an outage, before reserves and balancing can go into action. Several case studies were used to verify the performance of the grid-forming system-level controls in a wide range of operating conditions. These different control strategies have shown satisfactory and similar behaviour and appeared to be compatible with each other. In addition, it was observed that the robustness of the system was not only dependent on the amount of electrical inertia used but also strongly dependent on the location of the devices—in contrast to conventional ancillary services, where location does not matter. As a practical follow-up to MIGRATE, the work package 3 of OSMOSE is testing in situ a full-scale grid-forming unit for the synchronization of large power systems by multi-service hybrid storage (OSMOSE D3.1, 2019; OSMOSE D3.2, 2019).

Study on the effectiveness of emerging control methods, working under grid-following or grid-forming principles, was conducted for the Great Britain test system and for several benchmark systems. The results showed that modified and tuned grid-following control can allow a system to reach an approximate 65% share of inverter-based generation in the studied test systems while maintaining frequency, rotor angle, and voltage stability. Further, it was found that combining grid-following and grid-forming controls allows the system to further push the stability limit—to a theoretical 100% (MIGRATE D1.6, 2019). The ratio of inverter-based units with grid-following control or grid-forming control is system dependent (e.g., in the studied systems, it was 30%–40% of power electronic-interfaced units with grid-forming control). The proposed control methods for fast active power injection and supplementary damping control should be further studied in inverter-based units with grid-forming control (Perilla et al., 2020).

The Ireland power system test case of the EU MIGRATE assumed that existing fossil-fired generation is replaced by (large) converters of equivalent capacity, such that traditional power system security issues remained largely resolved, even with a 100% inverter-based system (Zhao & Flynn, 2021). To identify a lower bound on the grid-forming requirements (relative to grid-following converters) for such a system, various disturbances were applied at all network nodes for a range of converter configurations, and the ability of the system to satisfactorily survive such disturbances was observed (Figure 91). It was seen that a minimum grid-forming share of 35%–40% was required, based on the total online converter capacity (MVA). The stability boundary was shown to be ultimately dependent on the phase-locked loop performance of the grid-following converters. If, instead of assuming that the converters are large in size and located in traditional (fossil-fueled power station) network locations, they are assumed to be much smaller in size and somewhat unevenly distributed around a power system (depending on wind/solar plant sites, for example), then it was also shown that the previous grid-forming requirement could

be reduced by 8%–10%, measured as a system-wide average, although interregional differences in the grid-forming share would likely to require maintaining an adequate stability margin (Zhao & Flynn, 2021).

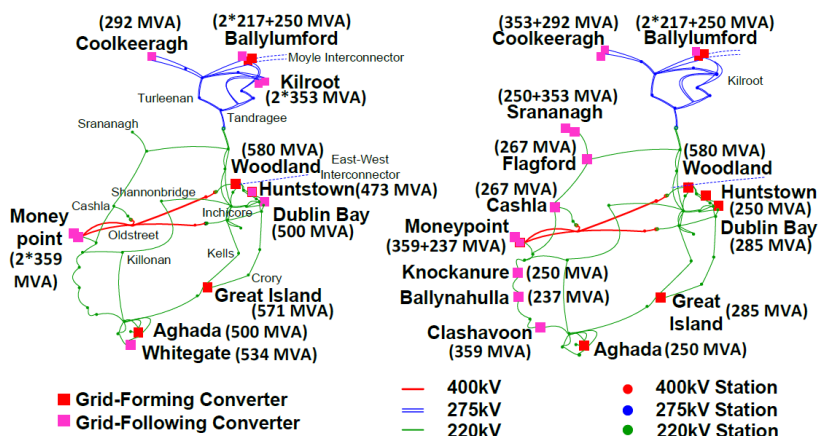

Figure 91. Ireland power system simulations for MIGRATE project: an "urban" distribution for the grid-forming and grid-following converters on the left and a "remote" distribution on the right (Source: Zhao & Flynn, 2021).

The project also studied new forms of subsynchronous controller interactions (SSCI). This motivated the proposal of mitigation measures—for instance, by optimal tuning of wind generators' converter controllers as well as by introducing auxiliary controllers in the converters. The project also developed a method to design, evaluate, and validate different mitigation solutions to tackle SSCI. Finally, a new approach based on artificial intelligence was proposed to manage SSCI risks during real-time operation (MIGRATE D1.6, 2019).

## 8. Conclusions

The design and operation of power and energy systems is an evolving field. As the ambitious targets toward net-zero carbon energy systems are announced globally, many scenarios are being made regarding how to reach the future energy systems, most of them involving large amounts of variable renewables, including wind and solar energy. Power systems are increasingly complex. The impact of both increased amounts of variable renewables and new electrification loads together with increased distribution system resources that require more coordination with transmission and distribution systems will mean somewhat different challenges to tackle for different systems.

Tools and methods to study future power and energy systems also need to evolve, and both short-term operational aspects (such as power system stability) and long-term aspects (such as resource adequacy) will probably see new paradigms of operation and design. The experience of operating and planning systems with large amounts of variable generation is accumulating, and research to tackle challenges of inverter-based, non-synchronous generation is on the way. Energy transitions and digitalization also bring new flexibility opportunities, both short and long term.

This report brings together experience and study results from 17 countries working in the international collaboration within the IEA Wind TCP Task 25. Main findings are reported on:

- How to incorporate wind and solar generation and forecasts within system operation and simulations (Section 2)
- How to plan for long-term adequacy of transmission grids and generation capacity (sections 3 and 4)
- How to manage the operation of power systems, including stability aspects (Section 5)
- How to increase the value of wind in future power and energy systems, avoiding unnecessary curtailments, providing system support from WPPs, and improving operational practices and flexibility (Section 6)
- Pushing the limits toward 100% renewable systems, highlighting challenges and evolving methodologies needed for the assessments (Section 7).

**Variability and uncertainty of power system-wide wind energy:** More data on large-scale measured wind power production are available, and they show strong smoothing impacts. In Europe, the aggregated wind generation drops to less than 5% of installed capacity only for 1 hour per year, and longer durations of less than 10% of installed capacity are rare (the max in a year is between 30 and 40 consecutive hours). Ramps during storms of 25% of capacity in an hour can hit a single country, but for larger countries even extreme ramping is closer to 10% of installed capacity. The storm events also bring about the largest forecast errors. Simulated time series have previously experienced challenges to capture the smoothing



impact, but the latest meteorological data sets, such as ERA5 in Europe, have shown good performance in representing future wind power fleets. There is good complementarity between wind and solar energy, reducing the combined variability. Short-term forecasts are still improving, and ways to simulate the forecast errors for power system studies are evolving.

**Transmission planning:** New transmission is required with high shares of wind generation. The benefits of transmission over the costs of infrastructure build-out are increasing at higher wind and solar shares. Regional transmission planning shows good experience in Europe, and special HVDC overlays augmented by HVAC links for the U.S. grid have shown a good benefit-to-cost ratio. A trend toward larger installations at sea, offshore grids, and hybrids such as energy islands are appearing in many countries and power systems, and they will add to the grid planning challenge.

**Ensuring long-term reliability and security of supply:** In most countries, wind energy has not, as yet, been considered when assessing long-term (strategic) reserve or capacity payments. Adequacy analyses should adapt to reflect wind power capacity value in both studied and neighboring areas (considering real import possibilities). The capacity value of wind will be higher for larger areas, while its decreasing trend with increased wind energy will not be as pronounced. For higher wind and solar shares, it is important to ensure that sufficient data are considered to capture extreme events and that multi-area methods are applied to account for neighboring areas when assessing the generation adequacy and the capacity value of wind. For future wind- and solar power-dominated systems, new metrics and tools are needed to capture the storage and demand-side flexibility in adequacy analyses.

**Ensuring short-term system reliability:** Wind integration studies have shown that for 30%–40% shares of wind in electricity demand, the possibility to balance wind and solar across a larger area reduced the balancing challenges, more transmission reduced the curtailment challenges, while additional storage for system-level demand-generation balancing was not necessary. Estimating the increase in operating reserve due to increased variability and uncertainty has evolved toward dynamic reserve setting. Experience shows that changing operational practices could offset increases due to increasing wind and solar capacity. System dynamics have become more important for assessments with higher wind shares. Ways to mitigate low inertia are already used in small- and medium-size systems such as Ireland, Texas, Great Britain, and the Nordic power systems, as well as peripheral parts of synchronous system such as Italy. Also, other dynamic stability issues due to a weak grid are becoming relevant when studying high shares of wind and solar, where new control techniques (such as deploying grid-forming inverter technology) can reduce the need for additional synchronous condensers and transmission lines.

**Maximizing the value of wind power in operations:** A more flexible power system can use variable energy sources at higher value. Hence, the main enablers in maximizing the value of wind power are outside wind power itself. However, wind power can also increase its value by providing system services—services for balancing and frequency control are already state of the art in some power systems,

with voltage control also emerging. New capabilities can be offered for stability support, and capabilities from grid-forming inverters have been demonstrated. Experience in curtailments in China shows how the grid reinforcements and increased power plant flexibility can help avoid the need to curtail wind energy. In Europe, curtailments are gradually increasing with increasing shares of wind and solar. Reinforcing the grid is seen as the major solution to manage this in the future. Also, operational practices to fully utilize the existing grid are important: using near-real-time information to determine security margins, as well as active power management (phase-shifting transformers, dynamic line rating, power flow controllers), and reactive power management (reactors/capacitors, synchronous compensators, STATCOM). Congestion management is evolving, and new ways to capture flexibility from distribution system connected resources are developing. One way to change operational practices is through markets. Market design to enable and incentivize flexibility from a range of sources and operation close to delivery will enhance the growth of wind and solar capacity. Enabling system services from wind and solar power plants provides not only a system-level benefit but adds a potential new revenue stream for wind and solar power in market environments. Benefits from flexibility from transmission, hydro and thermal power plants, storage, and the demand side are shown across a range of studies.

**Pushing the limits:** Some techno-economic studies have examined how hourly energy balances could be maintained in a 100% renewable power system and a net-zero energy system decarbonizing energy sectors beyond electricity. However, power system stability has often been overlooked as part of 100% (energy-balancing) studies, where the main focus is on hourly consumption-generation matching. No study comprehensively addresses both the long-term and short-term challenges so far. The first studies on stability of 100% IBR-connected systems have been made, showing promising results. IBRs can be highly flexible and controllable, with independent control over real and reactive current, and with an ability to shape the equipment's response to various grid conditions. Consequently, there could be opportunities to make IBRs behave in a more supportive manner than synchronous machines in some respects. However, the changes are so profound that a fundamental rethinking of power systems is required, including the definition of needed system services.

Wind and solar energy will certainly make a large contribution to future power systems and provide the added renewable energy needed for ambitious increases in electrification demand—150%–300% of current electricity demand. They also have the potential to form the backbone of future power systems when the full range of inverter capabilities are used. This is still a work in progress, where new paradigms of asynchronous power system operation and long-term resource adequacy are developed, with a suite of new tools and methods being implemented for system operators.

## Acknowledgments

The authors would like to acknowledge the following:

- REE (Marta Perez Garcia) for updated forecast error accuracy (Figure 21) and updated data on how many wind power plants are compliant with system support services.
- ERCOT (Julia Matevosyan) for updates in operating reserve requirements in Sections 5.1.1 and 6.3.4.
- IEA Wind TCP Task 36 Forecasting Operating Agent Gregor Giebel for commenting on text on future forecasting improvement potential.

## References

- ACP. 2020. Clean Power Annual 2020. Report by American Clean Power Association ACP, available at <https://cleanpower.org/wp-content/uploads/2021/07/ACP-CPA-2020-Public.pdf>
- Adam, G.P., Vrana, T.K., Li, R., Li, P., Burt, G. & Finney, S. 2019. "Review of technologies for DC grids – power conversion, flow control and protection", IET Power Electronics, 2019.
- Adams, J. Carter, C., Huang, S. 2017. ERCOT experience with Sub-synchronous Control Interaction and proposed remediation, PES T&D 2012, 2012, pp. 1-5, doi: 10.1109/TDC.2012.6281678.
- AEMO. 2017. Black System South Australia 28 September 2016. Australian Energy Market Operator (AEMO) report. Available at [https://www.aemo.com.au/-/media/Files/Electricity/NEM/Market Notices and Events/Power System Incident Reports/2017/Integrated-Final-Report-SA-Black-System-28-September-2016.pdf](https://www.aemo.com.au/-/media/Files/Electricity/NEM/Market_Notices_and_Events/Power_System_Incident_Reports/2017/Integrated-Final-Report-SA-Black-System-28-September-2016.pdf).
- AIGS. 2008. All island grid study. <http://www.dcenr.gov.ie/Energy/North-South+Cooperation+in+the+Energy+Sector/All+Island+Electricity+Grid+Study.htm>.
- Algarvio, H. & Knorr, K. 2017. New market products. Work Package 83 - Deliverable D83.2. IRPWind Project (<http://www.irpwind.eu>).
- Askeland, M., Jaehnert, S. & Korpås, M. 2016. Electricity Markets with Capacity Remuneration including Energy Storage. Presentation at the CEDREN Hydrobalance User Meeting. Available at: <http://www.cedren.no/Prosjekter/HydroBalance/Publikasjoner/HydroBalance-user-meeting-2016>.
- Asmine, M., Langlois, C.-E. & Aubut, N. 2016. Inertial response of wind power plants during a frequency disturbance on the Hydro-Quebec system – Event analysis and validation. Proceedings of WIW16.
- Aten, M., Shanahan, R., Mosallat, F., Wijesinghe, S. 2019. Dynamic simulations of a black starting offshore wind farm using grid forming converters. In: 18th Wind Integration Workshop. Energynautics GmbH, Dublin, Ireland, Oct 2019.
- Badrzadeh, B., Modi, N., Lindley, J., Jalali A., and Lu, J. 2021. Power System Operation With a High Share of Inverter-Based Resources: The Australian Experience. in IEEE Power and Energy Magazine, vol. 19, no. 5, pp. 46-55, Sept.-Oct. 2021, doi: 10.1109/MPE.2021.3088744.

- BEST PATHS D9.3. 2018. BEST PATHS DEMO#2: Final Recommendations For Interoperability Of Multivendor HVDC Systems. BEST PATHS H2020 EU project, <http://www.bestpaths-project.eu/contents/publications/d93--final-demo2-recommendations--vfinal.pdf>.
- Biellmann, H., Buquet, M., Chay, P., Schwery, A., Costan, V., Drommi, J.L. & Prime, G. 2020. "The benefits of implementing Synchronous Compensators in grids with high penetration of Renewables", C1102, CIGRE 2020.
- Biermann, K., Cali, Ü., Füller, G., Haubold, R., Heinze, D., Herrmann, O., Jursa, R., Lange, B., Moradi, J., Rohrig, K., Schlögl, F. & Söldner, S. 2005. Entwicklung eines Rechenmodells zur Windleistungsprognose für das Gebiet des deutschen Verbundnetzes. Report of the Institute for Solar Energy Systems (ISET), University Kassel for the Federal Ministry for Environment, Nature Conservation and Nuclear Safety.
- Bird, L., Lew, D., Milligan, M., Carlini, E.M., Estanqueiro, A., Flynn, D., GomezLazaro, E., Holttinen, H., Menemenlis, N., Orths, A., Eriksen, P.B., Smith, J.C., Soder, L., Sorensen, P., Altiparmakis, A., Yasuda, Y., Miller, J. 2016. Wind and solar energy curtailment: A review of international experience. *Renewable and Sustainable Energy Reviews*, vol. 65, pp. 577-586
- Bundesnetzagentur. 2019. Bundeskartellamt, Monitoring report 2019 - Key - findings and summary. Germany.
- Blom, E., Söder, L., & Risberg, D. 2020. Performance of multi-scenario equivalent hydropower models. *Electric power systems research*, vol. 187, 2020.
- Bloom, A., Townsend, A., Palchak, D., Novacheck, J., King, J., Barrows, C. & Gruchalla, K. 2016. Eastern Renewable Generation Integration Study. NREL/TP-6A20-64472. Golden, CO: National Renewable Energy Laboratory. Video available at: [https://www.youtube.com/watch?v=jx9\\_4GNkblQ](https://www.youtube.com/watch?v=jx9_4GNkblQ).
- Brinkman, G., Bain, D., Buster, G., Draxl, C., Das, P., Ho, J., Ibanez, E., Jones, R., Koebrich, S., Murphy, S., Narwade, V., Novacheck, J., Purkayastha, A., Rossol, M., Sigrin, B., Stephen, G., & Zhang, J. 2021. The North American Renewable Integration Study: A U.S. Perspective. Golden, CO: National Renewable Energy Laboratory. NREL/TP-6A20-79224. <https://www.nrel.gov/docs/fy21osti/79224.pdf>.
- Brown, T.W., Bischof-Niemz, T., Blok, K., Breyer, C., Lund, H. & Mathiesen, B.V. 2018. "Response to 'Burden of proof: A comprehensive review of the feasibility of 100% renewable-electricity systems,'" in *Renewable and Sustainable Energy Reviews*, Vol 96, 2018.

- Brown, P., Botterud, A. 2021. The Value of Inter-Regional Coordination and Transmission in Decarbonizing the US Electricity System. *Joule* 5, 115–134, January 20, 2021. Elsevier Inc. <https://doi.org/10.1016/j.joule.2020.11.013>.
- Buchhagen, C., Rauscher, C., Menze, A., Jung, J. 2015. BorWin1 – First Experiences with harmonic interactions in converter dominated grids. In Proceedings of International ETG Congress 2015, Bonn, Nov 17-18, 2015.
- Bundesnetzagentur. 2019. Bedarfsermittlung 2019-2030, Fact Sheet zur Bestätigung des Netzentwicklungsplans Strom, [www.netzausbau.de](http://www.netzausbau.de), Bonn, Germany, 2019.
- Bødal, E.F. & Korpås, M. 2017. Regional Effects of Hydrogen Production in Congested Transmission Grids with Wind and Hydro Power. In Proceedings of IEEE EEM Conf., 2017.
- Bødal, E.F. & Korpås, M. 2020. Value of Hydro Power Flexibility for Hydrogen Production in Constrained Transmission Grids. *Int. J Hydrogen Energy*, 45(2), 2020.
- Chao, H. 2012. “Competitive Electricity Markets with Consumer Subscription Service in a Smart Grid”, *Journal of Regulatory Economics*, Vol. 41 p. 155–180.
- Chernyakhovskiy, I., Koebrich, S., Gevorgian, V. & Cochran, J. 2019. Grid-friendly Renewable Energy: Solar and Wind Participation in Automatic Generation Control Systems. Report by NREL for Greening the Grid programme of USAID. Available at <https://www.nrel.gov/docs/fy19osti/73866.pdf>.
- Couto, A., Estanqueiro, A. 2020. Exploring Wind and Solar PV Generation Complementarity to Meet Electricity Demand. *Energies*, 13(4132), 21. <https://doi.org/10.3390/en13164132> .
- Couto, A., Duque, J., Algarvio, H., Estanqueiro, A., Pestana, R., Esteves, J. & Cao, Y. 2020. Impact of the dynamic line rating analysis in regions with high levels of wind and solar PV generation. In IEEE PES Innovative Smart Grid Technologies Europe (ISGT-Europe) 2020 Oct 26 (pp. 1206–1210). IEEE.
- Crosara, A., Tomasson, E. & Söder L. 2020. Generation Adequacy in the Nordic and Baltic Region: Case Studies from 2020 to 2050: Flex4RES Project Report, KTH Royal Institute of Technology, Stockholm, 2019. Available from <http://kth.diva-portal.org/smash/record.jsf?pid=diva2%3A1336561&dsid=6476>.

- Daly, P., Qazi, H.W. & Flynn, D. 2019. "RoCoF-constrained scheduling incorporating non-synchronous residential demand response", IEEE Trans. Power Systems, Vol. 34(5), pp. 3372–3383.
- Danti Lopez, I., Desmartin, M., Saguan, M. & Flynn, D. 2018. "Drivers for sub-hourly scheduling in unit commitment models", IEEE PES General Meeting, Portland, USA, 5-9 August 2018.
- Das, K., Altin, M., Hansen, A. D., Nuño Martinez, E., Sørensen, P. E., Thybo, G. W., Rangård, M., & Skytte, K.M. 2017. Facing the challenges of distribution systems operation with high wind power penetration. IEEE PowerTech 2017 Manchester.
- Dawkins, L.C. 2019. Weather and Climate Related Sensitivities and Risks in a Highly Renewable UK Energy System: A literature Review, UK Met Office, June 2019.
- DEA. 2018. Model Analysis of Flexibility of the Danish Power System. Danish Energy Agency DEA, May 2018 available at [https://ens.dk/sites/ens.dk/files/Globalcooperation/Publications\\_reports\\_papers/model\\_analysis\\_of\\_flexibility\\_of\\_the\\_danish\\_power\\_system.2018.05.15.pdf](https://ens.dk/sites/ens.dk/files/Globalcooperation/Publications_reports_papers/model_analysis_of_flexibility_of_the_danish_power_system.2018.05.15.pdf).
- Denholm, P., Sun, Y., Mai, T. 2019. <https://www.nrel.gov/docs/fy19osti/72578.pdf>.
- Dobschinski, J. 2014. How good is my forecast? Comparability of wind power forecast errors. Proceedings of the 13th International Workshop on Large-Scale Integration of Wind Power into Power Systems as well as on Transmission Networks for Offshore Wind Power Plants, 11-13 November 2014, Berlin, Germany, 2014.
- Dobschinski, J., Siefert, M., Saint-Drenan, Y.-M., Braun, A., Vogt, S. & Röpnack, A. 2016. Development of innovative weather and power forecast models for the grid integration of weather dependent energy sources. Proceedings of the WindAc conference, Cape Town, South Africa, November, 2016.
- Dobschinski J. & Kanefendt T. 2020. Freileitungsmonitoring auf Basis meteorologischer Informationen. Conference proceedings "Zukünftige Netze", Berlin, 2020.
- EC European Commission. 2020. An EU Strategy to harness the potential of offshore renewable energy for a climate neutral future. Available at: <https://eur-lex.europa.eu/legal-content/EN/TXT/PDF/?uri=CELEX:52020DC0741&from=EN>.

- EC/COWI. 2019. Study on Baltic offshore wind energy cooperation under BEMIP. Final report. DOI 10.2833/864823. Available at [https://ec.europa.eu/energy/studies/study-baltic-offshore-wind-energy-cooperation-under-bemip\\_en](https://ec.europa.eu/energy/studies/study-baltic-offshore-wind-energy-cooperation-under-bemip_en).
- EirGrid and SONI. 2010. All Island TSO Facilitation of Renewable Studies. June, 2010. Available at <http://www.eirgridgroup.com/site-files/library/EirGrid/Facilitation-of-Renewables-Report.pdf>.
- EirGrid and SONI. 2017. "DS3 System Services: Qualification Trials Process Outcomes and Learnings", November 2017. 116 p. Available at <https://www.eirgridgroup.com/site-files/library/EirGrid/DS3-System-Services-Qualification-Trials-Process-Outcomes-and-Learnings-2017.pdf>.
- EirGrid and SONI. 2018. Annual Renewable Energy Constraint and Curtailment Report 2017, published June 2018.
- EirGrid and SONI. 2019. All-Island Ten Year Transmission Forecast Statement. 288 p. Available at <http://www.eirgridgroup.com/site-files/library/EirGrid/All-Island-Ten-Year-Transmission-Forecast-Statement-2019.pdf>.
- EirGrid and SONI. 2021 Shaping our Electricity Future: Technical report. 190 p. Available at <https://www.eirgridgroup.com/site-files/library/EirGrid/Full-Technical-Report-on-Shaping-Our-Electricity-Future.pdf>.
- Electranix. 2021. Hawaiian Electric Island-Wide PSCAD Studies (Stage 2 System Impact Study). June, 2021. 50p. Available at <https://dms.puc.hawaii.gov/dms/DocumentViewer?pid=A1001001A21F14B62327F00172>
- Elia. 2018. Study on the review of the black start ancillary services. <https://www.elia.be/en/public-consultation/20181005-review-of-the-black-start-ancillary-service>. Accessed 25 November 2020.
- Elia. 2019. Future-proofing the EU energy system towards 2030 - Levers to realise the next phase of the energy transition in a timely and efficient way with maximum welfare for society. Technical report, [https://www.eliagroup.eu/-/media/project/elia/shared/documents/elia-group/publications/studies-and-reports/20191212\\_future\\_proofing\\_eu\\_system\\_2030.pdf](https://www.eliagroup.eu/-/media/project/elia/shared/documents/elia-group/publications/studies-and-reports/20191212_future_proofing_eu_system_2030.pdf).
- Energinet. 2018. System Perspective 2035. March 2018. Available online: <https://energinet.dk/Om-publikationer/Publikationer/RS-Analyse-Marts-2018-Systemperspektiv-2035>.
- Energinet. 2020. Redegørelse for Elforsyningssikkerhed (in Danish). Available online: <https://energinet.dk/Om-publikationer/Publikationer/Redegoerelse-for-elforsyningssikkerhed-2020>.



- ENTSO-E. 2018. Oscillation Event 03.12.2017. System Protection and Dynamics WG, March 2018. Available at [https://eepublicdownloads.entsoe.eu/clean-documents/SOC%20documents/Regional\\_Groups\\_Continental\\_Europe/OSCILLATION\\_REPORT\\_SPD.pdf](https://eepublicdownloads.entsoe.eu/clean-documents/SOC%20documents/Regional_Groups_Continental_Europe/OSCILLATION_REPORT_SPD.pdf).
- ENTSO-E 2020. Completing the map – Power System Needs in 2030 and 2040, November 2020. 70 p. Available at [https://eepublicdownloads.azureedge.net/tyndp-documents/loSN2020/200810\\_loSN2020mainreport\\_beforeconsultation.pdf](https://eepublicdownloads.azureedge.net/tyndp-documents/loSN2020/200810_loSN2020mainreport_beforeconsultation.pdf).
- ENTSO-E et al. 2020. “High Penetration of Power Electronic Interfaced Power Sources and the Potential Contribution of Grid Forming Converters”. Technical Report. 63 p. [High Penetration of Power Electronic Interfaced Power Sources and the Potential Contribution of Grid Forming Converters.pdf \(entsoe.eu\)](#).
- ENTSO-E TYNDP. 2020. Ten Year Network Development Plan (TYNDP). 90 p. Available at [https://eepublicdownloads.blob.core.windows.net/public-cdn-container/tyndp-documents/TYNDP2020/Forconsultation/TYNDP2020\\_Report\\_forconsultation.pdf](https://eepublicdownloads.blob.core.windows.net/public-cdn-container/tyndp-documents/TYNDP2020/Forconsultation/TYNDP2020_Report_forconsultation.pdf).
- EPRI. 2019. Flexibility Methods and Guidelines: Assessing Operational Flexibility in Systems with High Penetrations of Variable Generation – 2019 Update. Available at <https://www.epri.com/research/programs/067417/results/3002016257>.
- ERCOT. 2018. Dynamic Stability Assessment of High Penetration of Renewable Generation in the ERCOT Grid. 40p. Ercot. Available at [http://www.ercot.com/content/wcm/lists/144927/Dynamic\\_Stability\\_Assessment\\_of\\_High\\_Penetration\\_of\\_Renewable\\_Generatio....pdf](http://www.ercot.com/content/wcm/lists/144927/Dynamic_Stability_Assessment_of_High_Penetration_of_Renewable_Generatio....pdf)
- ESIG. 2019. Toward 100% Renewable Energy Pathways: Key Research Needs. Dec 2019. Available at [www.esig.energy](http://www.esig.energy).
- ETIPWind. 2021. Getting fit for 55 and set for 2050. June, 2021. 72p. Available at <https://etipwind.eu/files/reports/Flagship/fit-for-55/ETIPWind-Flagship-report-Fit-for-55-set-for-2050.pdf>
- EU. 2019. Methodology for the European resource adequacy assessment in accordance with Article 23 of Regulation (EU) 2019/943 of the European Parliament and of the Council of 5 June 2019 on the internal market for electricity. Available at [https://www.acer.europa.eu/Official\\_documents/Acts\\_of\\_the\\_Agency/Individual%20decisions%20Annexes/ACER%20Decision%20No%2024-2020\\_Annexes/ACER%20Decision%2024-2020%20on%20ERAA%20-%20Annex%20I.pdf](https://www.acer.europa.eu/Official_documents/Acts_of_the_Agency/Individual%20decisions%20Annexes/ACER%20Decision%20No%2024-2020_Annexes/ACER%20Decision%2024-2020%20on%20ERAA%20-%20Annex%20I.pdf).

- ESIG. 2021a. Transmission Planning for 100% Clean Electricity. Energy Systems Integration Group, Reston, VA. Available at <https://www.esig.energy/reports-briefs> or directly at <https://www.esig.energy/wp-content/uploads/2021/02/Transmission-Planning-White-Paper.pdf>
- ESIG. 2021b. Redefining Resource Adequacy for Modern Power Systems. Redefining Resource Adequacy Task Force. Energy Systems Integration Group, Reston, VA. Available at <https://www.esig.energy/reports-briefs> or directly at <https://www.esig.energy/wp-content/uploads/2021/08/ESIG-Redefining-Resource-Adequacy-2021.pdf>
- EU RealValue. 2018. Realising Value from Electricity Markets with Local Smart Electric Thermal Storage Technology. <https://cordis.europa.eu/project/id/646116>.
- EU-SysFlex D2.1. 2018. State-of-the-Art Literature Review of System Scarcities at High Levels of Renewable Generation. EU-SysFlex H2020 project, <https://eu-sysflex.com/documents/>
- EU-SysFlex D2.2. 2018. EU-SysFlex Scenarios and Network Sensitivities. EU-SysFlex H2020 project, <https://eu-sysflex.com/documents/>
- EU-SysFlex D2.4. 2020. Technical Shortfalls for Pan European Power System with High Levels of Renewable Generation. EU-SysFlex H2020 project, <https://eu-sysflex.com/documents/>
- EU-SysFlex D2.5. 2020. Financial Implications of High Levels of Renewables on the European Power System. EU-SysFlex H2020 project, <https://eu-sysflex.com/documents/>
- EU-SysFlex D2.6. 2021. Mitigation of the Technical Scarcities Associated with High Levels of Renewables on the European Power System, <https://eu-sysflex.com/documents/>
- EU-SysFlex D3.2. 2020. Conceptual market organisations for the provision of innovative system services: role models, associated market designs and regulatory frameworks. EU-SysFlex H2020 project, <https://eu-sysflex.com/documents/>
- EU-SysFlex D6.3. 2019. Grid simulations and simulation tools. Preliminary results. EU-SysFlex H2020 project, <https://eu-sysflex.com/documents/>
- EWITS. 2010. Eastern Wind Integration and Transmission Study. Enernex. NREL/SR-550-47078. 242 p. [https://www.nrcm.org/wp-content/uploads/2013/10/DOE\\_Eastern-Wind-Integration-and-Transmission-Study\\_2010.pdf](https://www.nrcm.org/wp-content/uploads/2013/10/DOE_Eastern-Wind-Integration-and-Transmission-Study_2010.pdf).

- eXtremOS. 2021. Final report to be posted online <https://extremos.ffe.de>.
- Fernandez, E., Albizu, I., Bedialauneta, M.T., Mazon, A.J. & Leite, P.T. 2016. Review of dynamic line rating systems for wind power integration. *Renewable and Sustainable Energy Reviews* 53, pp. 80–92.
- Flynn, D., Rather, Z., Ardal, A., D'Arco, S., Hansen, A.D., Cutululis, N.A., Sorensen, P., Estanquero, A., Gómez, E., Menemenlis, N., Smith, C. & Wang, Y. 2017. Technical impacts of high penetration levels of wind power on power system stability. *Wiley Interdisciplinary Reviews: Energy and Environment*, vol. 6, no. 2.
- Fournel, J., Prime, G. & Wang, Y. 2020. “Assessment of the dynamic frequency stability of the future Continental Europe power system – Interconnected incidents and system splits”, C4207, CIGRE 2020.
- GE. 2021. Canadian Provincial Grid Code Study. Report for The Wind Energy Institute of Canada and Natural Resources Canada’s Utility Forum. Sep 2021. 136 p. Available at <https://weican.ca/docs/Canadian%20Provincial%20Grid%20Code%20Study%20-%20Final%20Public%20R2.pdf>
- Gea-Bermúdez, J., Pade, L.-L., Koivisto, M.J. & Ravn, H.V. 2020. Optimal generation and transmission development of the North Sea region: impact of grid architecture and planning horizon, *Energy*, vol. 191, 116512, 2020.
- Gomes, V., Wang, Y., Breton, A., Mourier, M., Holicki, L. & Letzel, M. 2020. “Provision of FCR reserve by wind power plants: capability and performance assessment based on experimental results”, *Wind Integration Workshop* 2020.
- G-PST. 2021. Inaugural Research Agenda. Available at [https://globalpst.org/wp-content/uploads/042921G-PST-Research-Agenda-Master-Document-FINAL\\_updated.pdf](https://globalpst.org/wp-content/uploads/042921G-PST-Research-Agenda-Master-Document-FINAL_updated.pdf).
- Graabak, I., Jaehnert, S., Korpås, M. & Mo, B. 2017. Norway as a Battery for the Future European Power System—Impacts on the Hydropower System. *Energies* 10, no. 12: 2054. <https://doi.org/10.3390/en10122054>.
- Graabak I., Jaehnert S., Korpås M. & Mo B. 2019. Norway as a Battery for the Future European Power System – Comparison of Two Different Methodological Approaches. In: Helseth A. (eds) *Proceedings of the 6th International Workshop on Hydro Scheduling in Competitive Electricity Markets*. HSCM 2018. Springer, Cham. [https://doi.org/10.1007/978-3-030-03311-8\\_10](https://doi.org/10.1007/978-3-030-03311-8_10).

- Guminski, A., Böing, F., Murmann, A. & von Roon, S. 2018. System effects of high demand-side electrification rates: A scenario analysis for Germany in 2030. *WIREs Energy Environ.* 2019, 8: null. doi: 10.1002/wene.327.
- Gustavsen, B.A. & Mo, O. 2017. "Variable Transmission Voltage for Loss Minimization in Long Offshore Wind Farm AC Export Cables", *IEEE Transactions on Power Delivery*.
- Hansen, A. & Altin, M. 2015. Impact of advanced wind power ancillary services on power system. DTU Wind Energy E-0081. Available at: [http://orbit.dtu.dk/files/107186047/DTU\\_Wind\\_Energy\\_E\\_0081.pdf](http://orbit.dtu.dk/files/107186047/DTU_Wind_Energy_E_0081.pdf).
- Hansen, A., Altin, M. & Cutululis, N.A. 2015. Modelling of wind power plant controller, wind speed time series, aggregation and sample results. DTU Wind Energy E-0064. Available at: [http://orbit.dtu.dk/files/107186057/DTU\\_Wind\\_Energy\\_E\\_0080.pdf](http://orbit.dtu.dk/files/107186057/DTU_Wind_Energy_E_0080.pdf).
- Hasche, B., Keane, A. & O'Malley, M. 2011. Capacity Value of Wind Power, Calculation, and Data Requirements: the Irish Power System Case. *IEEE Transactions on Power Systems*, vol. 26, no. 1, pp. 420-430.
- Heard, B.P., Brook, B.W., Wigley, T.M.L. & Bradshaw, C.J.A. 2017. "Burden of proof: A comprehensive review of the feasibility of 100% renewable-electricity systems," in *Renewable and Sustainable Energy Reviews*, Vol 76.
- Heggarty, T., Bourmaud, JY., Girard, R. & Kariniotakis, G. 2019. "Multi-temporal assessment of power system flexibility requirement, *Applied Energy* 2019;238:1327–36, <https://doi.org/10.1016/j.apenergy.2019.01.198>.
- Heggarty, T., Bourmaud, JY., Girard, R. & Kariniotakis, G. 2020. "Quantifying power system flexibility provision", *Applied Energy* 279 (2020) 115852, <https://doi.org/10.1016/j.apenergy.2020.115852>.
- Helistö, N., Kiviluoma, J. & Holttinen, H. 2017. Sensitivity of electricity prices in energy-only markets with large amounts of zero marginal cost generation. *Proceedings. Article no. 7981893. 14th International Conference on the European Energy Market, EEM 2017, 6–9 June 2017, Dresden, Germany.* <https://doi.org/10.1109/EEM.2017.7981893>.
- Helistö, N., Kiviluoma, J. & Holttinen, H. 2018. Long-term impact of variable generation and demand side flexibility on thermal power generation. *IET Renewable Power Generation*, 12(6), 718–726. <https://doi.org/10.1049/iet-rpg.2017.0107>.
- Helistö, N., Kiviluoma, J., Holttinen, H., Lara, J.D. & Hodge, B.-M. 2019. Including operational aspects in the planning of power systems with large amounts

- of variable generation: a review of modeling approaches. *WIREs Energy Environment*, 8(5), e341. <https://doi.org/10.1002/wene.341>.
- Helistö, N., Kiviluoma, J. & Reittu, H. 2020. Selection of representative slices for generation expansion planning using regular decomposition. *Energy*, 211, 118585. <https://doi.org/10.1016/j.energy.2020.118585>.
- Helistö, N., Kiviluoma, J., Morales-España, G. & O'Dwyer, C. 2021. Impact of operational details and temporal representations on investment planning in energy systems dominated by wind and solar. *Applied Energy*, 290, 116712. <https://doi.org/10.1016/j.apenergy.2021.116712>.
- Hirth, L. & Müller, S. 2016. System-friendly wind power: How advanced wind turbine design can increase the economic value of electricity generated through wind power, *Energy Economics*, Volume 56, Pages 51–63, <https://doi.org/10.1016/j.eneco.2016.02.016>.
- Hodge, B.-M., Jain, H., Brancucci, C., Seo, G.-S., Korpås, M., Kiviluoma, J., Holttinen, H., et al. 2020. Addressing technical challenges in 100% variable inverter-based renewable energy power systems". *Wiley Interdisciplinary Reviews: Energy and Environment*, vol 9, iss. 5, e354 <https://doi.org/10.1002/wene.376>.
- Holttinen, H., Lemström, B., Meibom, P., Bindner, H., Orths, A., van Hulle, F., Ensslin, C., Hofmann, L., Winter, W., Tuohy, A., O'Malley, M., Smith, P., Pierik, J., Tande, J.O., Estanqueiro, A., Ricardo, J., Gomez, E., Söder, L., Strbac, G., Shakoor, A., Smith, J.C., Parsons, B., Milligan, M. & Wan, Y. 2007. Design and operation of power systems with large amounts of wind power. State-of-the-art report. Espoo, VTT. 119 p. + app. 25 p. VTT 119 Working Papers; 82 ISBN 978-951-38-6633-4. Available at: <http://www.vtt.fi/inf/pdf/workingpapers/2007/W82.pdf>.
- Holttinen, H., Meibom, P., Orths, A., van Hulle, F., Lang, B., O'Malley, M., Pierik, J., Ummels, B., Tande, J.O., Estanqueiro, A., Matos, M., Ricardo, J., Gomez, E., Söder, L., Strbac, G., Shakoor, A., Smith, J.C., Milligan, M. & Ela, E. 2009. Design and operation of power systems with large amounts of wind power. Final report, IEA WIND Task 25, Phase one 2006-2008. Espoo, VTT. 200 p. + app. 29 p. VTT Tiedotteita - Research Notes; 2493. Available at <http://www.vtt.fi/inf/pdf/tiedotteet/2009/T2493.pdf>.
- Holttinen, H., Orths, A.G., Eriksen, B., Hidalgo, J., Estanqueiro, A., Groome, F., Coughlan, Y., Neumann, H., Lange, B. & van Hulle, F. 2011. Currents of change. USA: IEEE. *IEEE Power & Energy Magazine*, Vol. 9, Nr. 6, Pp. 47–59. <https://ieeexplore.ieee.org/document/6049627>.

- Holtinen, H., Kiviluoma, J., Robitaille, A., Cutululis, N., Orths, A., van Hulle, F., Pineda, I., Lange, B., O'Malley, M., Dillon, J., Carlini, E.M., Vergine, C., Kondoh, J., Gibescu, M., Tande, J.O., Estanqueiro, A., Gomez, E., Söder, L., Smith, J.C., Milligan, M. & Lew, D. 2012. Design and operation of power systems with large amounts of wind power. Final summary report, IEA WIND Task 25, Phase two 2009 - 2011. Espoo: VTT. 81 p. + app. 13 p. (VTT Technology; 75) <http://www.vtt.fi/inf/pdf/technology/2012/T75.pdf>.
- Holtinen, H., Kiviluoma, J., Pineda, I., McCann, J., Clancy, M., Milligan, M., Eriksen, P.B., Orths, A. & Wolfgang, O. 2015. Reduction of CO2 emissions due to wind energy - methods and issues in estimating operational emission reductions. IEEE Power & Energy Society General Meeting, 26 - 30 July 2015, Denver, USA: IEEE. Proceedings, pp. 1-5. ISBN 978-1-4673-8040-9 doi:10.1109/PESGM.2015.7286288.
- Holtinen, H., Kiviluoma, J., Milligan, M., Smith, J.C., Dillon, J., Forcione, A., O'Malley, M., Dobschinski, J., van Roon, S., Cutululis, N., Orths, A., Eriksen, P.B., Carlini, E.M., Estanqueiro, A., Bessa, R., Söder, L., Farahmand, H., Torres, J.R., Jianhua, B., Kondoh, J., Pineda, I. & Strbac, G. 2016. Design and operation of power systems with large amounts of wind power. Final summary report, IEA WIND Task 25, Phase three 2012 - 2014. Espoo, VTT. 115 p. + app. 15 p. VTT Technology 268; <http://www.vtt.fi/inf/pdf/technology/2016/T268.pdf>.
- Holtinen, H. (ed) et al. 2018. Recommended Practices for Wind/PV Integration studies. RP16 Ed.2 issued by IEA Wind, available at: <https://iea-wind.org/iea-publications/>
- Holtinen, H., Kiviluoma, J., Levy, T., Jun, L., Eriksen, P. B., Orths, A., Cutululis, N., Silva, V., Neau, E., Dobschinski, J., van Roon, S., Dillon, J., Flynn, D., Carlini, E.M., Tanabe, R., Yasuda, Y., Ramirez, M., Torres, J.R., Vrana, T.K., Korpås, M., Estanqueiro, A., Couto, A., Gomez-Lazaro, E., Söder, L., Pudjianto, D., Hodge, B-M., Smith, J.C., Lew, D. & Fraile, D. 2019. Design and operation of power systems with large amounts of wind power: Final summary report, IEA WIND Task 25, Phase four 2015-2017. VTT Technical Research Centre of Finland. VTT Technology, No. 350 <https://doi.org/10.32040/2242-122X.2019.T350>.
- Holtinen H., Kiviluoma, J., Flynn, D., Smith, J.C., Orths, A., Eriksen, P.B., Cutululis, N., et al. (2020) System impact studies for near 100% renewable energy systems dominated by inverter based variable generation. IEEE TPWRS Oct 2020 doi: 10.1109/TPWRS.2020.3034924 open access <https://ieeexplore.ieee.org/document/9246271>
- Holtinen, H., Groom, A., Kennedy, E., Woodfin, D., Barroso, L., Orth, A., Ogimoto, K., Wang, C., Moreno, R., Parks, K. & Ackermann, T. 2021. Variable

Renewable Energy Integration: Status Around the World. IEEE Power & Energy Magazine, Vol. 19, Nov/Dec 2021 in print. USA: IEEE.

IEA. 2021. Net Zero by 2050. A Roadmap for the Global Energy Sector. Report by IEA, Paris, May 2021. Available at <https://www.iea.org/reports/net-zero-by-2050>.

IEA-RETD. 2016. Policies for Storing Renewable Energy: a Scoping Study of Policy Considerations for Energy Storage (RE-STORAGE). IEA Renewable Energy Technology Deployment, Utrecht.

IEA-RTE. 2021. Conditions and Requirements for the Technical Feasibility of a Power System with a High Share of Renewables in France Towards 2050. Technical report, [https://assets.rte-france.com/prod/public/2021-01/RTE-AIE\\_rapport%20complet%20ENR%20horizon%202050\\_EN.pdf](https://assets.rte-france.com/prod/public/2021-01/RTE-AIE_rapport%20complet%20ENR%20horizon%202050_EN.pdf).

IEA Wind TCP. 2021. Annual Report 2020. Available at <https://iea-wind.org/iea-publications/>.

Ikäheimo, J., Kiviluoma, J., Weiss, R. & Holttinen H. 2018. "Power-to-ammonia in future North European 100 % renewable power and heat system", International Journal of Hydrogen Energy. Vol. 43, Iss. 36, 2018. <https://doi.org/10.1016/j.ijhydene.2018.06.121>.

Ikäheimo, J., Pursiheimo, E., Kiviluoma, J. & Holttinen, H. 2019. "Role of power to liquids and biomass to liquids in a nearly renewable energy system". Vol 13, Iss. 7, pp. 1179–1189. <https://doi.org/10.1049/iet-rpg.2018.5007>.

Jaehnert, S., Korpås, M., Doorman, G.L. & Hyldbakk, I.M. 2015. On the profit variability of power plants in a system with large-scale renewable energy sources. In: 12th Int. conf. on the European Energy Market, EEM 2015. IEEE Press. ISBN 978-1-4673-6691-5.

Jain, A., Das, K., Göksu, Ö. & Cutululis, N.A. 2018. Control solutions for blackstart capability and islanding operation of offshore wind power plants. In: Proceedings of the 17th International Wind Integration workshop. Energynautics GmbH, Stockholm, Sweden Oct 2018.

Jain, A., Sakamuri, J.N., Das, K., Göksu, Ö. & Cutululis, N.A. 2019. Functional requirements for blackstart and power system restoration from wind power plants. In: 2nd International Conference on Large-Scale Grid Integration of Renewable Energy in India. Energynautics GmbH, New Delhi, India.

Jain, A., Saborío-Romano, O., Sakamuri, J.N. & Cutululis N.A. 2021. Blackstart from HVDC-connected offshore wind: Hard versus soft energization. IET Renewable Power Gener. 2021;15:127–138. <https://doi.org/10.1049/rpg2.12010>.

- Jorgenson, J., Awara, S., Stephen, G., Mai, T., 2021. A systematic evaluation of wind's capacity credit in the Western United States. *Wind Energy*. 2021;1–15. <https://doi.org/10.1002/we.2620>.
- Jost, D., Braun, A. & Fritz, R. 2015. Dynamic dimensioning of frequency restoration reserve capacity based on quantile regression. 12th International Conference on the European Energy Market (EEM). doi:10.1109/EEM.2015.7216769.
- Jourdier, B. 2020. "Evaluation of ERA5, MERRA-2, COSMO-REA6, NEWA and AROME to simulate wind power production over France", *Advances in Science and Research*. 17. 63-77. 10.5194/asr-17-63-2020.
- Karbouj, H., Flynn, D., Qazi, H., Rather, Z. 2019. "Non-synchronous fast frequency reserves in renewable energy integrated power systems: a critical review", *International Journal of Electrical Power and Energy Systems*, Vol. 106, pp. 488–501.
- Kasmi, G. 2021. Assessment of the potential of Earth observation data and deep convolutional neural networks to improve the estimation and forecast of the solar power production in France. PSL University - doctoral school Ingénierie des Systèmes, Matériaux, Mécanique, Énergétique, <http://www.theses.fr/s262404>.
- Kern, S., Zorn, T., Weichenhain, U. & Elsen, S. 2019. Hybrid projects. How to reduce costs and space of offshore development: North Seas offshore energy clusters study. Report by Directorate-General for Energy (European Commission) and Roland Berger GmbH. DOI 10.2833/416539.
- Kiviluoma, Juha, Holttinen, Hannele, Scharff, Richard, Weir, David Edward, Cutullis, Nicolaos, Litong-Palima, Marisciel, Milligan, Michael. 2014. Index for wind power variability. 13th International Workshop on Large-Scale Integration of Wind Power into Power Systems as well as on Transmission Networks for Offshore Wind Farms, WIW14, 11 - 13 November 2014, Berlin, Germany: EnergyNautics. Available at <https://community.iea-wind.org/task25/home>.
- Kiviluoma, J., Holttinen, H., Weir, D., Scharff, R., Söder, L., Menemenlis, N., Cutullis, N.A., Lopez, I.D., Lannoye, E., Estanqueiro, A., Gomez-Lazaro, E., Zhang, Q., Bai, J., Wan, Y-H. & Milligan, M. 2016. Variability in large scale wind power generation. *Wind Energy*, vol. 19, Iss. 9, Sep. 2016. <https://onlinelibrary.wiley.com/doi/epdf/10.1002/we.1942>.
- Kiviluoma, J., Rinne, E. & Heliö, N. 2017. Comparison of flexibility options to improve the value of variable power generation. *Int. J. Sustain. Energy*. doi:10.1080/14786451.2017.1357554.



- Koivisto, M., Maule, P., Cutululis, N. & Sørensen, P. 2019. Effects of Wind Power Technology Development on Large-scale VRE Generation Variability, IEEE PowerTech, Milan, Italy, June 2019. (<https://doi.org/10.1109/PTC.2019.8810687>).
- Koivisto, M., Jónsdóttir, G.M., Sørensen, P., Plakasa, K. & Cutululis, N. 2020a. Combination of meteorological reanalysis data and stochastic simulation for modelling wind generation variability, Renewable Energy, vol. 159, pp. 991–999, October 2020 (<https://doi.org/10.1016/j.renene.2020.06.033>).
- Koivisto, M., Gea-Bermudez, J., & Sørensen, P. 2020b. North Sea offshore Grid development: Combined optimization of grid and generation investments towards 2050, IET Renewable Power Generation, vol. 14, no. 8, pp. 1259-1267, 2020. <https://doi.org/10.1049/iet-rpg.2019.0693>.
- Koivisto, M., Gea-Bermudez, J., Kanellas, P., Das, K. & Sørensen, P. 2020c. North Sea region energy system towards 2050: integrated offshore grid and sector coupling drive offshore wind installations, Wind Energy Science, 5, 1705–1712, 2020. <https://doi.org/10.5194/wes-5-1705-2020>.
- Koralewicz, P., Shah S., Gevorgian V., Wallen R., Jha K., Mashtare D., Gadiraju K. Viswanadha R., Tiwari A. 2020. Impedance Analysis and PHIL Demonstration of Reactive Power Oscillations in a Wind Power Plant Using a 4-MW Wind Turbine. Frontiers in Energy Research Vol 8 DOI=10.3389/fenrg.2020.00156 Available at <https://www.frontiersin.org/article/10.3389/fenrg.2020.00156>
- Korpås, M. & A Botterud, A. 2020. Optimality Conditions and Cost Recovery in Electricity Markets with Variable Renewable Energy and Energy Storage. MIT CEEPR Working Paper 2020-005. <http://ceepr.mit.edu/publications/working-papers/721>.
- Kristiansen, M. 2019. Multinational transmission expansion planning: Exploring engineering-economic decision support for a future North Sea Offshore Grid”, Doctoral theses at NTNU;2019:134. Available at <https://ntnuopen.ntnu.no/ntnu-xmlui/handle/11250/2601704>.
- Kuwahata, R. & Merk, P. 2017. German paradox demystified : why is need for balancing reserves reducing despite increasing VRE production? Proceedings of 16th Int'l Wind Integration Workshop, Berlin, Germany, 25-27 October, 2017.
- Kuwahata, R., Michiorri, A. & Yasuda, Y. 2019. Back-Casting Analysis How Dynamic Line Rating Would Increase Usage Ratio of European Interconnection, WIW19 8 p.

- Lacerda, M., Couto, A., Estanqueiro, A. 2017. Wind Power Ramps Driven by Windstorms and Cyclones. *ENERGIES*, vol. 10, no. 10, pp. 1475.
- Li, B., Basu, S., Watson, S.J. & Russchenberg, H.W.J. 2020. Quantifying the Predictability of a 'Dunkelflaute' Event by Utilizing a Mesoscale Model. *Journal of Physics: Conference Series*. 2020;1618(6):062042.
- Li, B., Basu, S., Watson, S.J. & Russchenberg, H.W.J. 2021. Mesoscale modeling of a "Dunkelflaute" event. *Wind Energy*. 2021;24(1):5–23.
- Lindroos, T.J., Mäki, E., Koponen, K., Hannula, I., Kiviluoma, J. & Raitila, J. 2021. Replacing fossil fuels with bioenergy in district heating – Comparison of technology options, *Energy*, Volume 231, 2021, 120799, ISSN 0360-5442, <https://doi.org/10.1016/j.energy.2021.120799>.
- Little, E., Bortolotti, S., Bourmaud, J.-Y., Karangelos, E. & Perez, Y. 2021. Optimal Transmission Topology for Facilitating the Growth of Renewable Power Generation, *Powertech* 2021. Available at <https://arxiv.org/abs/2103.15677>.
- Loutan, C., Klauer, P., Chowdhury, S., Hall, S., Morjaria, M., Chadliev, V., Milam, N., Milan, C. & Gevorgian, V. 2017. Demonstration of Essential Reliability Services by a 300- MW Solar Photovoltaic Power Plant. NREL Technical report NREL/TP-5D00-67799, March 2017. Available at <https://www.nrel.gov/docs/fy17osti/67799.pdf>.
- MAF. 2020. Mid-term Adequacy Forecast 2020 Edition. Executive Summary available at [https://eepublicdownloads.entsoe.eu/clean-documents/sdc-documents/MAF/2020/MAF\\_2020\\_Executive\\_Summary.pdf](https://eepublicdownloads.entsoe.eu/clean-documents/sdc-documents/MAF/2020/MAF_2020_Executive_Summary.pdf). Appendix 1 - Detailed Results and Input Data Available at [https://eepublicdownloads.entsoe.eu/clean-documents/sdc-documents/MAF/2020/MAF\\_2020\\_Appendix\\_1\\_Input\\_Data\\_Detailed\\_Results.pdf](https://eepublicdownloads.entsoe.eu/clean-documents/sdc-documents/MAF/2020/MAF_2020_Appendix_1_Input_Data_Detailed_Results.pdf).
- Mai, T., Mowers, M., Eurek, K. 2021. Competitiveness Metrics for Electricity System Technologies. Technical Report NREL/TP-6A20-72549 February 2021. Available at <https://www.nrel.gov/docs/fy21osti/72549.pdf>.
- Market4RES. 2016. Post-2020 framework for a liberalised electricity market with a large share of renewable energy sources. Executive summary of EU project Market4RES. Available at <http://market4res.eu/wp-content/uploads/160037-Market4Res-execsum-EN-02.pdf>
- Martínez Turégano, J., Añó-Villalba, S., Bernal-Pérez, S., Peña, R. & Blasco-Gimenez, R. 2018. Mixed grid-forming and grid-following wind power plants for black start operation. In *Proceedings of 17th International Workshop on Large-scale Integration of Wind Power into Power Systems as*

well as on Transmission Networks for Offshore Wind Power Plants, WIW 2018. Energynautics. ISBN: 978-3-9820080-1-1.

- Matevosyan, J. 2019. Evolution of ERCOT's Frequency Control and Ancillary Services for Higher Levels of Inverter-Based Generation. ESIG webinar presentation Feb 20, 2019. Available at <https://www.esig.energy/event/webinar-evolution-of-ercots-frequency-control-and-ancillary-services-while-integrating-a-high-share-of-inverter-based-generation/>
- Miettinen, J.J. & Holttinen, H. 2018. Impacts of wind power forecast errors on the real-time balancing need: a Nordic case study. IET Renewable Power Generation. 13(2), 227-233. <https://doi.org/10.1049/iet-rpg.2018.5234>
- Miettinen, J., Holttinen, H. & Hodge, B-M. 2020. Simulating wind power forecast error distributions for spatially aggregated wind power plants. Wind Energy, 23(1), 45–62. <https://doi.org/10.1002/we.2410>.
- MIGRATE D1.6. 2019. Demonstration of Mitigation Measures and Clarification of Unclear Grid Code Requirements. Available at <https://www.h2020-migrate.eu/downloads.html>.
- MIGRATE D3.3. 2020. WP3 - Control and Operation of a Grid with 100 % Converter-Based Devices - Deliverable 3.3: New options for existing system services and needs for new system services. Available at <https://www.h2020-migrate.eu/downloads.html>.
- MIGRATE D3.4. 2019. Deliverable 3.4. New options in system operation, January 2019. Available at <https://www.h2020-migrate.eu/downloads.html>.
- Milligan, M., Hodge, B., Kirby, B. & Clark, C. 2012. "Integration Costs: Are They Unique to Wind and Solar Energy?" NREL Report No. CP-5500-54905. Preprint, 12 pp. Available at: <http://www.nrel.gov/docs/fy11osti/51860.pdf>.
- Milligan, M. & Kirby, B. 2009. "Calculating Wind Integration Costs: Separating Wind Energy Value from Integration Cost Impacts." NREL Technical report TP-550-46275. Available at <http://www.nrel.gov/docs/fy09osti/46275.pdf>.
- Milligan, M., Ela, E., Hodge, B.M., Kirby, B., Lew, D., Clark, C. & Lynn, K. 2011. "Cost-Causation and Integration Cost Analysis for Variable Generation". NREL Report No. TP-5500-51860, 37 pp.
- Milligan, M., Frew, B., Ibanez, E., Kiviluoma, J., Holttinen, H. & Söder, L. 2017. Capacity value assessments for wind power. Wiley Interdisciplinary Reviews: Energy and Environment 6(1). Wiley. doi:10.1002/wene.226.

- Mills, A. D., Levin, T., Wisser, R., Seel, J., Botterud, A. 2020. "Impacts of variable renewable energy on wholesale markets and generating assets in the United States: A review of expectations and evidence," *Renewable and Sustainable Energy Reviews*, vol. 120, 2020. <https://doi.org/10.1016/j.rser.2019.109670>.
- MISO. 2021. Renewable Integration Impact Assessment (RIIA). Available at <https://cdn.misoenergy.org/RIIA%20Summary%20Report520051.pdf>.
- Modi, N., Badrzadeh, B., Halley, A., Louis, A., Jalali, A. 2020. Operational manifestation of low system strength conditions – Australian experience. CIGRE Paper for C2-124, Session 48, Paris 2020.
- Morales-España, G., Nycander, E. & Sijm, J. 2021. "Reducing CO2 Emissions by Curtailing Renewables: Examples from Optimal Power System Operation." *Energy Economics* 99 (July 1, 2021): 105277. <https://doi.org/10.1016/j.eneco.2021.105277>.
- Morin, J., Prime, G. & Wang, Y. 2019. "Probabilistic estimation of the aFRR requirement in the future European power system with high RES penetration", Wind Integration Workshop 2019. Energynautics GmbH.
- Most, D., Giannelos, S., Yueksel-Erguen, I., Beulertz, D., Haus, U-U., Charousset-Brignol, S., Frangioni, A. 2020. A Novel Modular Optimization Framework for Modelling Investment and Operation of Energy Systems at European Level. ZIB-report. urn:nbn:de:0297-zib-78079. <https://opus4.kobv.de/opus4-zib/frontdoor/index/index/docId/7807>
- Mousavi, M. & Flynn, D. 2018. "Impact of modelling non-normality and stochastic dependence of variables on operating reserve determination for power systems with high penetration of wind power", *International Journal of Electrical Power and Energy Systems*, Vol. 97, pp. 146–154.
- MTEP. 2019. MTEP19 Executive Summary and Report. Available at MTEP19 Executive Summary and Report.pdf.
- Murcia Leon, J. P., Koivisto, M.J., Sørensen, P. & Magnant, P. 2021. Power Fluctuations in High Installation Density Offshore Wind Fleets. *Wind Energ. Sci. Discuss.* [preprint], in review, 2020. <https://doi.org/10.5194/wes-2020-95>.
- Müller, S., Holttinen, H., Taibi, E., Smith, J.C., Fraile, D. & Vrana, T.-K. 2018. System Integration Costs – a Useful Concept that is Complicated to Quantify? In Proceedings of 17th International Workshop on Large-scale Integration of Wind Power into Power Systems as well as on Transmission Networks for Offshore Wind Power Plants, WIW 2018. Energynautics. Available at <https://iea-wind.org/task25/>

- NGET. 2019. National Grid Electricity Transmission: Report into the power interruption following Generator Trips and Frequency Excursion On 9th August 2019. Available as Appendix in [https://www.ofgem.gov.uk/sites/default/files/docs/2019/09/eso\\_technical\\_report\\_-\\_appendices\\_-\\_final.pdf](https://www.ofgem.gov.uk/sites/default/files/docs/2019/09/eso_technical_report_-_appendices_-_final.pdf)
- Nickell, L. 2017. SPP, CREPC Spring meeting.
- Nordic TSOs. 2018. Future System Inertia V2. Available at <https://docs.en-tsoe.eu/id/dataset/nordic-report-future-system-inertia/resource/6efce80b-2d87-48c0-b1fe-41b70f2e54e4>.
- Novacheck, J., Sharp, J., Schwarz, M., Donohoo-Vallett, P., Tzavelis, Z., Buster, G. & Rossol, M. 2021 (Forthcoming). The Evolving Role of Extreme Weather Events in the U.S. Power System with High Variable Generation Penetrations. Golden, CO: National Renewable Energy Laboratory.
- NREL. 2020. Interconnection Seams Study, Available at <https://www.nrel.gov/docs/fy21osti/76850.pdf>.
- NREL. 2021. Extreme Weather Events study, to be published.
- NSCOGI. 2012. WG1 Grid Configuration. Available: <http://www.bene-lux.int/NSCOGI/> Bruxelles, November 2012.
- NSON-DK. 2020. North Sea Offshore Network Denmark (NSON-DK). Conclusions and recommendations. Available at <https://orbit.dtu.dk/en/activities/north-sea-offshore-network-denmark-nson-dk-conclusions-and-recomm>.
- Nuño, E., Maule, P., Hahmann, A., Cutululis, N., Sørensen, P. & Karagali, I. 2018. Simulation of transcontinental wind and solar PV generation time series. *Renewable Energy* 118, pp. 425-436. doi:10.1016/j.renene.2017.11.039.
- O'Dwyer, C., Ryan, L. & Flynn, D. 2017.: "Efficient large-sale energy storage dispatch: challenges in future high renewables systems", *IEEE Trans. Power Systems*, Vol. 32(5), pp. 3439–3450.
- Olauson, J., Bladh, J., Lönnberg, J. & Bergkvist, M. 2016. A New Approach to Obtain Synthetic Wind Power Forecasts for Integration Studies. *Energies*, article no 800.
- Olauson, J. 2018. ERA5: The new champion of wind power modelling? *Renewable Energy* 126, pp. 322-331. doi:10.1016/j.renene.2018.03.056.
- Orths, A. & Hansen, A.B. 2019. Sector Coupling in Denmark – Entering the next Phase of the Green Transition. Proceedings of the 18<sup>th</sup> International Wind Integration Workshop WIW19, 16-18 Oct, 2019, Dublin, Ireland.

- OSMOSE D2.1. 2019. Methodology for error forecasts at European scale: D2.1", public project deliverable of WP2. Available at <https://www.osmose-h2020.eu/download/d2-1-methodology-for-error-forecasts-at-european-scale/>
- OSMOSE D2.2. 2019. Candidate market mechanisms and regulatory frameworks. public project deliverable of WP2. Available at <https://www.osmose-h2020.eu/download/d2-2-candidate-market-mechanisms-and-regulatory-frameworks>.
- OSMOSE D3.1. 2019. Multi-service control algorithm for converters - Deliverable number: D3.1. Public project deliverable of WP3, available at <https://www.osmose-h2020.eu/download/d3-1-multi-services-control-algorithm-for-converters/>
- OSMOSE D3.2. 2019. Overall Specifications of the Demonstrations - D3.2. Public project deliverable of WP3, available at <https://www.osmose-h2020.eu/download/d3-2-overall-specifications-of-the-demonstrations/>
- O'Sullivan, J., Rogers, A., Flynn, D., Smith, P., Mullane A. & O'Malley, M. 2014. "Studying the Maximum Instantaneous Non-Synchronous Generation in an Island System—Frequency Stability Challenges in Ireland," in IEEE Transactions on Power Systems, vol. 29, no. 6, pp. 2943–2951, Nov. 2014, doi: 10.1109/TPWRS.2014.2316974. Pérez-Rúa, J-A, Das, K & Cutululis, NA. 2019. Optimum sizing of offshore wind farm export cables, International Journal of Electrical Power and Energy Systems, vol. 113, pp. 982–990.
- PCWIS. 2016. Pan Canadian Wind Integration Study. Available at: <https://canwea.ca/wind-integration-study/>.
- Pérez-Rúa, J-A., Stolpe, M., Das, K. & Cutululis, NA. 2020. Global Optimization of Offshore Wind Farm Collection Systems, IEEE Transactions on Power Systems, vol. 35, no. 3, pp. 2256–2267.
- Perilla, A., Papadakis, S., Rueda Torres, J.L., van der Meijden, M., Palensky, P. & Gonzalez-Longatt, F. 2020. "Transient Stability Performance of Power Systems with High Share of Wind Generators Equipped with Power-Angle Modulation Controllers or Fast Local Voltage Controllers" Energies 13, no. 16: 4205. <https://doi.org/10.3390/en13164205>.
- Perroy, E., Lucas, D. & Debusschere, V. 2020. "Provision of Frequency Containment Reserve Through Large Industrial End-Users Pooling," in IEEE Transactions on Smart Grid, vol. 11, no. 1, pp. 26–36, Jan. 2020. <https://doi.org/10.1109/TSG.2019.2916623>.

- plan4RES. 2021. Synergistic Approach of Multi-Energy Models for an European Optimal Energy System Management Tool, EU project 2017–2021, <https://www.plan4res.eu/>
- Prime, G. & Wang, Y. 2019. “Power system cost related to the reduction of inertia”, Session 5, ESIG 2019, <https://www.esig.energy/>.
- Princeton University. 2020. Net Zero America. Available at <https://www.princeton.edu/news/2020/12/15/big-affordable-effort-needed-america-reach-net-zero-emissions-2050-princeton-study>
- PROMOTioN. 2020. Progress on meshed HVDC offshore transmission networks. 2016–2020. Deliverable 12.4 – Final Deployment Plan. Available at <https://www.promotion-offshore.net/results/deliverables>.
- Pudjianto, D., Badesa, Luis. & Strbac, G. 2021. “Whole-system value of long-duration energy storage in a net-zero emission energy system for Great Britain,” a report for SSE Renewables, Feb 2021.
- Rebello, E., Watson, D. 2019. Program of Energy Research and Development - Wind Integration System Operator Research Program - Research Summary. Wind Energy Institute of Canada, North Cape, Prince Edward Island, Canada, 2019. Available at <https://weican.ca/docs/publications/PERD%20Public%20Summary%20Report.pdf>
- Rebello, E., Watson D., Rodgers, M. 2019. "Performance Analysis of a 10 MW Wind Farm in Providing Secondary Frequency Regulation: Experimental Aspects," in IEEE Transactions on Power Systems, vol. 34, no. 4, pp. 3090-3097, July 2019, doi: 10.1109/TPWRS.2019.2891962
- Rebello, E., Watson, D., Rodgers, M. 2020. Ancillary services from wind turbines: automatic generation control (AGC) from a single Type 4 turbine. Wind Energy Science Vol. 5 (1) pp 225—236. <https://wes.copernicus.org/articles/5/225/2020/> DOI 10.5194/wes-5-225-2020
- Rebello, E., Rodgers, M. 2021. Wind Farm Enhanced Capability Demonstration Project. Technical report, 35p. Wind Energy Institute of Canada, North Cape, Prince Edward Island, Canada. Available at <https://weican.ca/docs/5030%20-%20Utility%20Forum%20-%20Task%201%20Report.pdf>
- Riesz, J., Gilmore, J. & MacGill, I. 2018. “Frequency control ancillary service market design: insights from the Australian National Electricity Market,” The Electricity Journal, vol. 28, no. 3, pp. 86–99, 2015.

- Ringkjøb, H-K., Haugan, P.M. & I. Solbrekke, M. 2018. "A review of modelling tools for energy and electricity systems with large shares of variable renewables," in Renewable and Sustainable Energy Reviews, Vol 96.
- Roscoe, A., Brogan, P., Elliott, D., Knueppel, T., Gutierrez, I., Campion J.-C. P., Silva, R. D. 2019. Practical Experience of Operating a Grid Forming Wind Park and its Response to System Events. Proceedings of 18th Wind Integration Workshop, November 2019.
- RTE. 2017. Réseaux électriques intelligents - Valeur économique, environnementale et déploiement d'ensemble (in French). <https://assets.rte-france.com/prod/public/2020-12/Reseaux%20electriques%20intelligents%202017%20%20rapport%20complet.pdf> .
- RTE TNDP. 2019. French transmission network development plan - 2019 EDITION, <https://www.rte-france.com/en/analyses-trends-and-perspectives/ten-year-network-development-plan>.
- RTE-Avere France. 2019. Enjeux du développement de l'électromobilité pour le système électrique (in French). Available at <https://www.concerte.fr/system/files/concertation/Electromobilite%CC%81%20-%20Synth%C3%A8se%20vFinale.pdf>
- RTE. 2020. La transition vers un hydrogène bas carbone – Atouts et enjeux pour le système électrique à l'horizon 2030–2035 (in French). Technical report. Available at <https://www.concerte.fr/system/files/concertation/Rapport%20Hydrogene%20VF.pdf>.
- Ruhnau, O. 2021. How flexible electricity demand stabilizes wind and solar market values: the case of hydrogen electrolyzers, ZBW - Leibniz Information Centre for Economics, Kiel, Hamburg.
- Sakamuri, J.N., Altin, M., Hansen, A.D. & Cutululis, N.A. 2017. Coordinated frequency control from offshore wind power plants connected to multi terminal DC system considering wind speed variation. I E T Renewable Power Generation 11(8), pp. 1226–1236. doi:10.1049/iet-rpg.2016.0433.
- Sanchis, G., et al. 2015. Europe's future secure and sustainable electricity infrastructure – e-Highway2050 project results. e-Highway2050 Project Booklet, 2015 at <http://www.e-highway2050.eu/>.
- Shah, S., Koralewicz, P., Gevorgian, V., Liu, H., Fu, J. 2021a. "Impedance Methods for Analyzing Stability Impacts of Inverter-Based Resources: Stability Analysis Tools for Modern Power Systems," in IEEE Electrification Magazine, vol. 9, no. 1, pp. 53-65. doi: 10.1109/MELE.2020.3047166.



- Shah, S., et al. 2021b. "Which IBRs are Causing Oscillations – a flexible and scalable impedance scan tool to evaluate small-signal stability, control interactions, and oscillations in IBR grids," Presentation to NERC IRPWG, August 2021. Available at [https://www.nerc.com/comm/RSTC/IRPWG/IRPWG\\_Meeting\\_Presentations - 2021\\_08\\_19.pdf](https://www.nerc.com/comm/RSTC/IRPWG/IRPWG_Meeting_Presentations_-_2021_08_19.pdf)
- Shah, S., Koralewicz, P., Gevorgian, V., Wallen, R. 2021c. "Sequence Impedance Measurement of Utility-Scale Wind Turbines and Inverters Reference Frame, Frequency Coupling, and MIMO/SISO Forms," in IEEE Transactions on Energy Conversion, doi: 10.1109/TEC.2021.3093516.
- Siefert, M., Hagedorn, R., Braun, A., Dobschinski, J., Fritz, R. & Good, G. 2017 Development of innovative weather and power forecast models for the grid integration of weather dependent energy sources, final report of the German BMWi project EWeLiNE (FKZ 0325500A), Fraunhofer Institute for Wind Energy and Energy System Technology, IWES.
- Sperstad, I.B., Kjølle, G., Gjerde, O., Vrana, T.K., Jakobsen, S.H., Turunen, J. & Haarla, L. 2018. "Vulnerability analysis of HVDC contingencies in the Nordic power system", CIGRE Paris.
- SPP. 2020. The value of transmission report. Available at spp.org.
- Statnett, Fingrid, Energinet, Svenska Kraftnät, 2016. Challenges and Opportunities for the Nordic power system.
- Steiner, A., Koehler, C., Metzinger, I., Braun, A., Zirkelbach, M., Ernst, D., Tran, P. & Ritter, B. 2017. Critical weather situations for renewable energies e Part A: Cyclone detection for wind power. Renewable Energy 101, pp. 41–50. ISSN 0960-1481.
- Strbac, G., Pudjianto, D., Sansom, R., Djapic, P., Ameli, H., Shah, N. & Hawkes, S. 2018. Analysis of Alternative UK Heat Decarbonisation Pathways For the Committee on Climate Change. June 2018.
- Strbac, G., Pudjianto, D., Aunedi, M., Djapic, P., Teng, F., Zhang, X., Ameli, H., Moreira, R. & Brandon, N. 2020. "Role and value of flexibility in facilitating cost-effective energy system decarbonisation" Progress in Energy, Volume 2, Number 4, Sept 2020. <https://iopscience.iop.org/article/10.1088/2516-1083/abb216>.
- Strbac, G. & Pudjianto, D. 2021. Flexibility in Great Britain. May 2021. Carbon Trust. Available at: <https://publications.carbontrust.com/flex-gb/analysis/>.
- Strbac, G., Papadaskalopoulos, D., Chrysanthopoulos, N., Estanqueiro, A., Algarvio, H., Lopes, F., de Vries, L., Morales-España, G., Sijm, J.,

- Hernandez-Serna, R. & Kiviluoma, J. 2021. Decarbonization of Electricity Systems in Europe: Market Design Challenges. *IEEE Power and Energy Magazine*, 19(1), pp. 53–63.
- Sun, H., Guo, Q., Qi, J., Ajarapu, V., Bravo, R., Chow, J., Li, Z., Moghe, R., Nasr-Azadani, E., Tamrakar, U., Taranto, G.N., Tonkoski, R., Valverde, G., Wu, Q. & Yang, G. 2019. "Review of Challenges and Research Opportunities for Voltage Control in Smart Grids," in *IEEE Transactions on Power Systems*, vol. 34, no. 4, pp. 2790–2801, July 2019. doi: 10.1109/TPWRS.2019.2897948.
- Sun, Y., Frew, B., Levin, T., Hytowitz, R.B., Kwon, J., Mills, A.D., Xu, Q., Heidarifar, M., Singhal, N., de Mello, P., Ela, E., Botterud, A., Zhou, Z., Hobbs, F. & Montanes, C.C. 2021. Research Priorities and Opportunities in United States Competitive Wholesale Electricity Markets. NREL report for Grid Modernization Laboratory Consortium, USDoE, May 2021. Available at <https://www.nrel.gov/docs/fy21osti/77521.pdf>.
- Surendran, R., Hogan, W.W., Hui, H., Yu, C-N. 2016. Scarcity Pricing in ERCOT, FERC Technical Conference, June 27-29, 2016. Available at [https://cms.ferc.gov/sites/default/files/2020-05/20160629114652-3%2520-%2520FERC2016\\_Scarcity%2520Pricing\\_ER-COT\\_Resmi%2520Surendran.pdf](https://cms.ferc.gov/sites/default/files/2020-05/20160629114652-3%2520-%2520FERC2016_Scarcity%2520Pricing_ER-COT_Resmi%2520Surendran.pdf).
- SvK Svenska Kraftnät. 2018. Long term market analysis, 2018 (in Swedish), available from <https://www.svk.se/siteassets/om-oss/rapporter/2019/langsiktig-marknadsanalys-2018.pdf>.
- Söder, L., Milligan, M., Orths, A., Pellingner, C., Kiviluoma, J., Silva, V., Lopez-Botet Zulueta, M., Flynn, D. & O'Neill, B. 2017. Comparison of Integration Studies of 30-40 Percent Energy Share from Variable Renewable Sources. In: *Proceedings of 16th Wind Integration Workshop – Berlin, October 2017*.
- Söder, L., Tómasson, E., Estanqueiro, A., Flynn, D., Hodge, B.-M., Kiviluoma, J., Korpås, M., Neau, E., Couto, A., Pudjianto, D., Strbac, G., et al. 2020. Review of wind generation within adequacy calculations and capacity markets for different power systems. *Renewable and Sustainable Energy Reviews*, Volume 119, ISSN 1364-0321, <https://doi.org/10.1016/j.rser.2019.109540>.
- Söder, L. 2021. System and integration costs in wind and solar energy: Definitions and analysis. *Energiforsk*. Available from <https://energiforsk.se/media/30270/system-and-integration-costs-energiforskrapport-2021-801.pdf>.

- Tanabe, R., Amano, H. & Yokoyama, A. 2017. An Analytical Method for Assessing Flexible Resource Adequacy of Power Systems with a High Share of Renewables. Power TECH.
- Tanabe, R. & Yokoyama, A. 2019. Pumped-Storage Hydropower Operation Scheduling Method for Net Load Ramp Leveling
- Terna. 2018. National Development Plan 2018. Available at Terna.
- Terna. 2020. National Development Plan 2020. Available at Terna. [https://download.terna.it/terna/Piano%20di%20Sviluppo%202020\\_8d7db1ffa4ca9e7.pdf](https://download.terna.it/terna/Piano%20di%20Sviluppo%202020_8d7db1ffa4ca9e7.pdf).
- Terrier, V. 2017. North European Power Systems Reliability, M.Sc. Thesis. KTH, Sweden. Available at: <http://kth.divaportal.org/smash/record.jsf?pid=diva2%3A1077673&dswid=-8334>.
- TSO2020. 2020. Stability Analysis of an International Electricity System connected to Regional and Local Sustainable Gas Systems. Final report available at [http://tso2020.eu/wp-content/uploads/2020/01/TSO2020\\_Final\\_Report\\_TUD.pdf](http://tso2020.eu/wp-content/uploads/2020/01/TSO2020_Final_Report_TUD.pdf).
- Tómasson, E. & Söder, L. 2017. Multi-area generation adequacy and capacity credit in power system analysis, 2017 IEEE innovative smart grid technologies - Asia (ISGT-Asia).
- Tómasson, E. & Söder, L. 2018. Generation Adequacy Analysis of Multi-Area Power Systems With a High Share of Wind Power. IEEE Transactions on Power Systems, vol. 33, no. 4, pp. 3854–3862, 2018.
- TSO-DSO. 2019. “TSO-DSO Report - An integrated approach to active system management with the focus on TSO-DSO coordination in congestion management and balancing”, [https://eepublicdownloads.entsoe.eu/clean-documents/Publications/Position%20papers%20and%20reports/TSO-DSO\\_ASM\\_2019\\_190416.pdf](https://eepublicdownloads.entsoe.eu/clean-documents/Publications/Position%20papers%20and%20reports/TSO-DSO_ASM_2019_190416.pdf).
- USDoE. 2021. Land-Based Wind Market Report: 2021 Edition. Available at <https://emp.lbl.gov/wind-technologies-market-report/>
- Vibrant energy. 2020. “ZeroByFifty” Presentation at the Energy Systems Integration Group technical workshop (online), November 11, 2020. [https://www.vibrantcleanenergy.com/wp-content/uploads/2020/11/ESIG\\_VCE\\_11112020.pdf](https://www.vibrantcleanenergy.com/wp-content/uploads/2020/11/ESIG_VCE_11112020.pdf).

- Vittal, E., O'Malley, M., Keane, A. 2010. A steady-state voltage stability analysis of power systems with high penetrations of wind. IEEE Trans. PWRs, Vol. 25 (1), pp. 433–442.
- Vrana, T.K. & Torres Olguin, R.E. 2015. Technology perspectives of the North Sea Offshore and storage Network (NSON). Technical Report TR A7490, SINTEF Energy. Available at <https://sintef.brage.unit.no/sintef-xmlui/handle/11250/2400329>.
- Vrana, T.K. 2016. "Review of HVDC Component Ratings: XLPE Cables and VSC Converters", IEEE Energycon.
- Vrana, T.K. & Mo, O. 2016. "Optimal Operation Voltage for Maximal Power Transfer Capability on Very Long HVAC Cables", Energy Procedia, 2016
- Vrana, T.K., Aas, E.S., Reigstad, Mo, O. 2017a. "Impact of Present and Future HVDC Links on the Nordic Power Grid", IET ACDC.
- Vrana, T.K., Flynn, D., Gomez-Lazaro, E., Kiviluoma, J., Marcel, D., Cutululis, N. & J. Smith, C. 2017b. "Wind power within European grid codes: Evolution, status and outlook", WILEY WIREs.
- Vrana, T.K., Trilla, L. & Attya, A. 2017c. "Development of a Generic Future Grid Code regarding Wind Power in Europe", WIW Berlin.
- Vrana, T.K. & Härtel, P. 2018. "Estimation of investment model cost parameters for VSC HVDC transmission infrastructure", Electric Power System Research.
- Vrana, T.K., Attya, A. Trilla, T. 2020. "Future-oriented Generic Grid Code regarding Wind Power Plants in Europe", Electrical Power & Energy Systems.
- Wolter, C., Klinge Jacobsen, H., Rogdakis, G., Zeni, L. & Cutululis, N.A. 2016. Overplanting in offshore wind power plants in different regulatory regimes. In: 15th wind Integration workshop – International Workshop on LargeScale Integration of Wind Power into Power Systems as well as on Transmission Networks for Offshore Wind Power Plants.
- WindEurope. 2016. Ten Commandments of the wind industry on balancing markets. Position paper, available at <https://windeurope.org/wpcontent/uploads/files/policy/position-papers/WindEurope-TenCommandments-of-the-Wind-Industry-on-Balancing-Markets.pdf>.
- WindEurope. 2018. Renewables system integration – a system wide approach to cost and value. Position paper, 2018. Available at <https://windeurope.org/policy/position-papers/renewables-system-integration-a-system-wide-approach-to-cost-and-value/>.

- Wiser, R. 2017. Value of Wind: Other Measures to Avoid the Value Drop. IEA Wind Technology Collaborative Platform. Lyngby, Denmark, November 2017. Available at [https://backend.orbit.dtu.dk/ws/portalfiles/portal/139941854/Wiser\\_Wind\\_ValueMitigation.pdf](https://backend.orbit.dtu.dk/ws/portalfiles/portal/139941854/Wiser_Wind_ValueMitigation.pdf)
- Xie, X., Zhang, X., Liu, H., Liu H., Li, Y., Zhang, C. 2017. Characteristic Analysis of Subsynchronous Resonance in Practical Wind Farms Connected to Series-Compensated Transmissions. IEEE Transactions on Energy Conversion Vol. 32 No 3, Sep 2017.
- Yasuda, Y., Bird, L., Carlini, E.M. et al., 2021. C-E (Curtailment – Energy Share) Map: An Objective and Quantitative Measure to Evaluate Wind and Solar Curtailment. Submitted to RSER.
- You, R., Barahona, B., Chai, J., Cutululis, N.A. 2013. A novel wind turbine concept based on an electromagnetic coupler and the study of its fault ride-through capability. Energies, Vol. 6, pp. 6120–6136.
- Zhao, X. & Flynn, D. 2021. "Dynamic studies for 100% converter-based Irish power system", IET RPG Conference, Dublin, Ireland, March 2021.

## Appendix A: Ongoing projects

Country/ Organization	Name/Description	Years	Link
EU project	TradeRES: New Markets Design & Models for 100% Renewable Power Systems. New designs for markets with very high shares of non-dispatchable generation as well as new models and simulation tools for assessing their performance.	2020–2024	<a href="https://traderes.eu/">https://traderes.eu/</a>
EU project	Spine: Building a workflow and data management platform for modelling as well as a Julia-based energy systems model, a modelling platform and a case study for planning with operational constraints.	2017–2021	<a href="http://www.spine-model.org/">http://www.spine-model.org/</a>
EU project	OSMOSE: Optimal System Mix of flexibility Solutions for European electricity	2018–2021	<a href="https://www.osmose-h2020.eu/">https://www.osmose-h2020.eu/</a>
EU project	openENTRANCE: open ENergy TRansition ANalyses for a low-Carbon Economy. Open modelling platform for analyses of decarbonization of the energy system in Europe	–2023	<a href="https://openentrance.eu/">https://openentrance.eu/</a>
EU project	Smart4RES: (WP5) Advanced approaches for use cases with high renewable energy source penetration (i.e., for congestion management, management of geographic island systems, coordination of renewable energy source with storage)	2019–2023	<a href="https://www.smart4res.eu/">https://www.smart4res.eu/</a>
EU project	ERIGrid 2.0: Smart grid research, technology development, validation, and rollout	2020–2024	<a href="https://erigrd2.eu/">https://erigrd2.eu/</a>
EU project	InnoDC: Innovative Tools for Offshore Wind and DC Grids	2018–	<a href="https://innodc.org/">https://innodc.org/</a>
EU project	WinGrid (Wind Farm – Grid Interactions: Exploration and Development): Network grid assessment of hydrostatic transmission-based wind farms, coordination of system-wide fast frequency response from wind turbines (farms)	2019–2023	<a href="https://www.wingrid.org/">https://www.wingrid.org/</a>
EU project	SysFlex: Pan-European system with an efficient coordinated use of flexibilities for the integration of a large share of renewable energy sources to come up with new types of services that will meet the needs of the system with more than 50% of renewable energy sources	2017–2022	<a href="https://eu-sysflex.com/">https://eu-sysflex.com/</a>

Country/ Organization	Name/Description	Years	Link
Denmark	Planning Energy Islands 2030: Two islands with 3 GW (Northsea) or 2 GW (Baltic Sea) including potential connections to neighbours, potential cross-sector elements		<a href="https://en.energinet.dk/Green-Transition/Energy-Islands">https://en.energinet.dk/Green-Transition/Energy-Islands</a>
ENTSO-E	Regional transmission planning methodology development for the identification of system needs and CBA, also for offshore hybrid projects (that are connected to multiple markets and sector coupling)		<a href="https://tyndp.entsoe.eu/">https://tyndp.entsoe.eu/</a>
Energy System Integration Group (ESIG)	Task force on Macrogrid Transmission Overlay Task force on Redefining Resource Adequacy	2020-	<a href="https://www.esig.energy/system-planning-working-group/">https://www.esig.energy/system-planning-working-group/</a>
Finland	FlexiB: Flexibility from heating and cooling buildings, assessing the value of flexibility from new heating and cooling concepts	2020–2024	<a href="https://www.researchgate.net/project/FlexiB-Integration-of-building-flexibility-into-future-energy-systems">https://www.researchgate.net/project/FlexiB-Integration-of-building-flexibility-into-future-energy-systems</a>
Finland	HOPE: Developing tools and solutions for the multi-objective optimization of energy systems, creating reference systems	2020–2022	<a href="https://clicinnovation.fi/project/hope/">https://clicinnovation.fi/project/hope/</a>
France	Learning to Run a Power Network Challenge 2021 (RTE, Electric Power Research Institute): Potential of artificial intelligence to address variations in demand and generation profiles with increasing shares of RES to help human operators operating the grid in real time; 2020 open contest run on academic data sets, will be tested on real data in 2021; open to worldwide participation	2020-	<a href="https://www.epri.com/l2rpn">https://www.epri.com/l2rpn</a>
Germany	SIROP- On the way to scenario interoperability	2021-2024	<a href="https://www.iee.fraunhofer.de/de/projekte/suche/2021/SIROP.html">https://www.iee.fraunhofer.de/de/projekte/suche/2021/SIROP.html</a>
Germany	Gridcast - Increased network security through flexible weather and power forecast models based on stochastic and physical hybrid methods	2017-2022	<a href="http://gridcast.iee.fraunhofer.de/">http://gridcast.iee.fraunhofer.de/</a>
Germany	WindRamp - Observer-supported prediction of grid congestions and possible feed-in of offshore wind energy for operational grid management and trading processes	2020-2023	<a href="https://www.energymeteo.com/customers/research_projects/windramp.php">https://www.energymeteo.com/customers/research_projects/windramp.php</a>
Germany	WAFB4.0 - Increasing transmission capacities in the power grid through weather-dependent dynamic line rating using data-driven and fibre optical methods	2021-2024	<a href="https://www.iee.fraunhofer.de/en/research_projects.html">https://www.iee.fraunhofer.de/en/research_projects.html</a>

<b>Country/ Organization</b>	<b>Name/Description</b>	<b>Years</b>	<b>Link</b>
Germany	eXtremOS: European deep decarbonization scenario—decarbonization pathways for all energy end use sectors (including sector-coupling measures) and the resulting effect on the energy supply and transport infrastructure (European transmission and gas network analyses)	2018–2021	<a href="https://extremos.ffe.de">https://extremos.ffe.de</a>
G-PST	Global Power System Transformation Consortium	2020–	<a href="https://globalpst.org/resources/">https://globalpst.org/resources/</a>
Ireland	Energy storage and demand-side flexibility within future electricity markets: Deployment of active measures to improve network utilization to avoid transmission and distribution network expansion, including dynamic line ratings	2017–2022	<a href="https://energyinstitute.ucd.ie/research/">https://energyinstitute.ucd.ie/research/</a>
Ireland	The Energy Systems Integration Partnership Programme (ESIPP) aims to address operational, planning, and technological innovations in the evolving integrated energy system, and to identify end use energy solutions in electricity, gas, heat and water that can deliver flexibility, sustainability, security of supply and competitiveness	2015-2021	<a href="https://esipp.ie/">https://esipp.ie/</a>
Ireland	The EMPower (Emissions and Fuel Mix, Markets and Costs, Power Flows and Networks, and End Use & Rates of Uptake) programme investigates the technical challenges of achieving a decarbonisation vision, considering renewables variability, role of markets and interconnection, unpredictability of consumer behaviour, impacts of new system loads and performance of legacy distribution networks	2019-2023	<a href="https://energyinstitute.ucd.ie/work-with-us/industry-affiliates-programme-iap/">https://energyinstitute.ucd.ie/work-with-us/industry-affiliates-programme-iap/</a>
International Renewable Energy Agency (IRENA)	FlexTool 3.0: Developing the third version of the energy systems optimization tool geared for ease of use	2021–2022	<a href="https://www.irena.org/energytransition/Energy-System-Models-and-Data/IRENA-FlexTool">https://www.irena.org/energytransition/Energy-System-Models-and-Data/IRENA-FlexTool</a>
NSWPH	Technical and economic studies on North Sea Wind Power Hubs		<a href="https://northseawindpowerhub.eu/knowledge">https://northseawindpowerhub.eu/knowledge</a>
Nordic project	BaltHub: Interconnecting the Baltic Sea countries via offshore energy hubs	2021–2022	<a href="https://feee.ktu.edu/projects/interconnecting-baltic-sea-countries-via-offshore-energy-hubs-balthub/">https://feee.ktu.edu/projects/interconnecting-baltic-sea-countries-via-offshore-energy-hubs-balthub/</a>
Nordic project	FasTen: Decarbonization of Baltic countries	2020–2021	<a href="https://cris.vtt.fi/en/projects/fast-flexible-and-secure-decarbonisation-of-the-baltic-states-pos">https://cris.vtt.fi/en/projects/fast-flexible-and-secure-decarbonisation-of-the-baltic-states-pos</a>



Country/ Organization	Name/Description	Years	Link
Nordic project	Amber: Decarbonization of Baltic countries	2021–2022	<a href="https://cris.vtt.fi/en/projects/impacts-of-ambitious-energy-policy-pathways">https://cris.vtt.fi/en/projects/impacts-of-ambitious-energy-policy-pathways</a>
Norway	NTRANS: Norwegian Centre for Energy Transition Strategies. Use case regarding large-scale deployment of floating offshore wind power in Norway, system modelling activities, expansion planning models for low-carbon scenario in Europe 2050	–2028	<a href="https://www.ntnu.no/ntrans">https://www.ntnu.no/ntrans</a>
Norway	FME CINELDI: Norwegian Research Centre for Intelligent Electricity Distribution	2016–2024	<a href="https://www.sintef.no/projectweb/cineldi/">https://www.sintef.no/projectweb/cineldi/</a>
Norway	FME NorthWind: Norwegian Research Centre on Wind Energy. Power system-related work, for example, Ph.d. on optimization of multi-energy carrier options for wind power in the North Sea	2021–2029	<a href="https://www.northwindresearch.no/">https://www.northwindresearch.no/</a>
Norway	HydroConnect: Impacts of connecting Norwegian hydropower to continental Europe and the United Kingdom. Utilization of large-scale hydropower for balancing variable renewable energy	2021–2025	<a href="https://www.sintef.no/en/projects/2021/hydroconnect/">https://www.sintef.no/en/projects/2021/hydroconnect/</a>
Portugal	OPTIGRID Methodology-for-the-dynamic-line-rating-analysis-and-optimal-management-of-power-networks  OptiRES Advanced-Models-for-Optimal-Grid-Operation-with-High-Variable-Renewable-Energy-Penetration	2018–2021	<a href="https://optigrid.ineg.pt/">https://optigrid.ineg.pt/</a>  <a href="https://www.researchgate.net/project/OptiRES-Advanced-Models-for-Optimal-Grid-Operation-with-High-Variable-Renewable-Energy-Penetration">https://www.researchgate.net/project/OptiRES-Advanced-Models-for-Optimal-Grid-Operation-with-High-Variable-Renewable-Energy-Penetration</a>
Spain	FLEXENER: Flexible Energy System for the Efficient Integration of New Decarbonisation Technologies	2021–2023	
United States	Atmosphere to electrons to grid (A2E2G)		<a href="https://www.energy.gov/eere/wind/renewable-systems-integration">https://www.energy.gov/eere/wind/renewable-systems-integration</a>
United States	Grid modernization initiative GMLC		<a href="https://www.energy.gov/gmi/grid-modernization-lab-consortium">https://www.energy.gov/gmi/grid-modernization-lab-consortium</a>

Title	<b>Design and operation of energy systems with large amounts of variable generation</b> Final summary report, IEA Wind TCP Task 25
Author(s)	Hannele Holttinen et al.
Abstract	<p>This report summarises findings on wind integration from the 17 countries or sponsors participating in the International Energy Agency Wind Technology Collaboration Programme (IEA Wind TCP) Task 25 from 2006–2020. Both real experience and studies are reported. Many wind integration studies incorporate solar energy, and most of the results discussed here are valid for other variable renewables in addition to wind.</p> <p>The national case studies address several impacts of wind power on electric power systems. In this report, they are grouped under long-term planning issues and short-term operational impacts. Long-term planning issues include grid planning and capacity adequacy. Short-term operational impacts include reliability, stability, reserves, and maximising the value of wind in operational timescales (balancing related issues). The first section presents the variability and uncertainty of power system-wide wind power, and the last section presents recent studies toward 100% shares of renewables. The appendix provides a summary of ongoing research in the national projects contributing to Task 25 for 2021–2024.</p> <p>The design and operation of power and energy systems is an evolving field. As ambitious targets toward net-zero carbon energy systems are announced globally, many scenarios are being made regarding how to reach these future decarbonized energy systems, most of them involving large amounts of variable renewables, mainly wind and solar energy. The secure operation of power systems is increasingly challenging, and the impacts of variable renewables, new electrification loads together with increased distribution system resources will lead to somewhat different challenges for different systems. Tools and methods to study future power and energy systems also need to evolve, and both short-term operational aspects (such as power system stability) and long-term aspects (such as resource adequacy) will probably see new paradigms of operation and design. The experience of operating and planning systems with large amounts of variable generation is accumulating, and research to tackle the challenges of inverter-based, nonsynchronous generation is on the way. Energy transition and digitalization also bring new flexibility opportunities, both short and long term.</p>
ISBN, ISSN, URN	ISBN 978-951-38-8757-5 ISSN-L 2242-1211 ISSN 2242-122X (Online) DOI: 10.32040/2242-122X.2021.T396
Date	October 2021
Language	English
Pages	188 p. + app. 4 p.
Name of the project	
Commissioned by	IEA Wind TCP
Keywords	grid integration, wind integration, electricity markets, flexibility, capacity value, grid reinforcement
Publisher	VTT Technical Research Centre of Finland Ltd P.O. Box 1000, FI-02044 VTT, Finland, Tel. 020 722 111, <a href="https://www.vttresearch.com">https://www.vttresearch.com</a>

## **Design and operation of energy systems with large amounts of variable generation**

### **Final summary report, IEA Wind TCP Task 25**

This report summarises findings on wind integration from the 17 countries or sponsors participating in the International Energy Agency Wind Technology Collaboration Programme (IEA Wind TCP) Task 25. Both real experience and studies are reported. The national case studies address several impacts of wind power on electric power systems. In this report, they are grouped under long-term planning issues and short-term operational impacts. Long-term planning issues include grid planning and capacity adequacy. Short-term operational impacts include reliability, stability, reserves, and maximising the value of wind in operational timescales. The first section presents the variability and uncertainty of power system-wide wind power, and the last section presents recent studies toward 100% shares of renewables. The appendix provides a summary of ongoing research in the national projects contributing to Task 25 for 2021–2024.

ISBN 978-951-38-8757-5  
ISSN-L 2242-1211  
ISSN 2242-122X (Online)  
DOI: 10.32040/2242-122X.2021.T396